

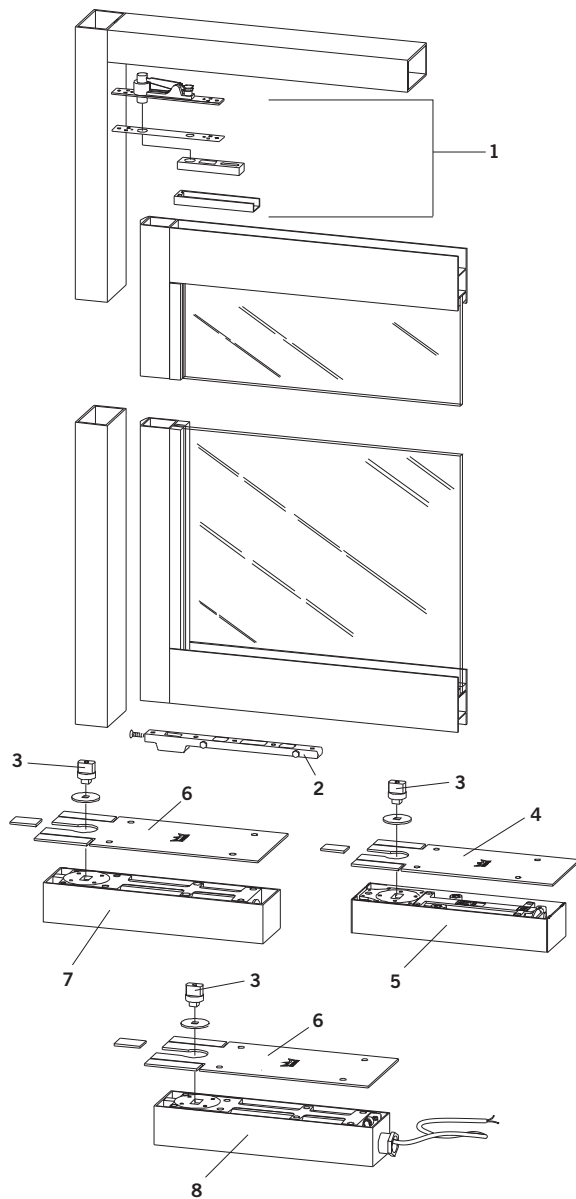

Applications and
Accessories

DORMA BTS

Aluminum Door & Frame Center Hung - Double or Single Acting



BTS 75V Packages		
Components	BTS 75V/A - Center Hung, Double-Acting	BTS 75V/G - Center Hung, Single-Acting
1. Top Pivot	8062	8062
2. Bottom Arm	7422	7422
3. Spindle	74010	80010
4. Cover Plate	7510	7510
5. Closer and Cement Case	BTS 75V	BTS 75V

BTS 80 Packages		
Components	BTS 80/A - Center Hung, Double-Acting	BTS 80/G - Center Hung, Single-Acting
1. Top Pivot	8062	8062
2. Bottom Arm	7422	7422
3. Spindle	74010	80010
6. Cover Plate	7410	7410
7. Closer and Cement Case	BTS 80	BTS 80

BTS 80 EMB Package	
Components	BTS 80 EMB/G - Center Hung, Single-Acting
1. Top Pivot	8062
2. Bottom Arm	7422
3. Spindle	80010
6. Cover Plate	7410
8. Closer and Cement Case	BTS 80 EMB

Specify hand for G packages.

Wood or Steel Door & Frame Center Hung - Double or Single Acting

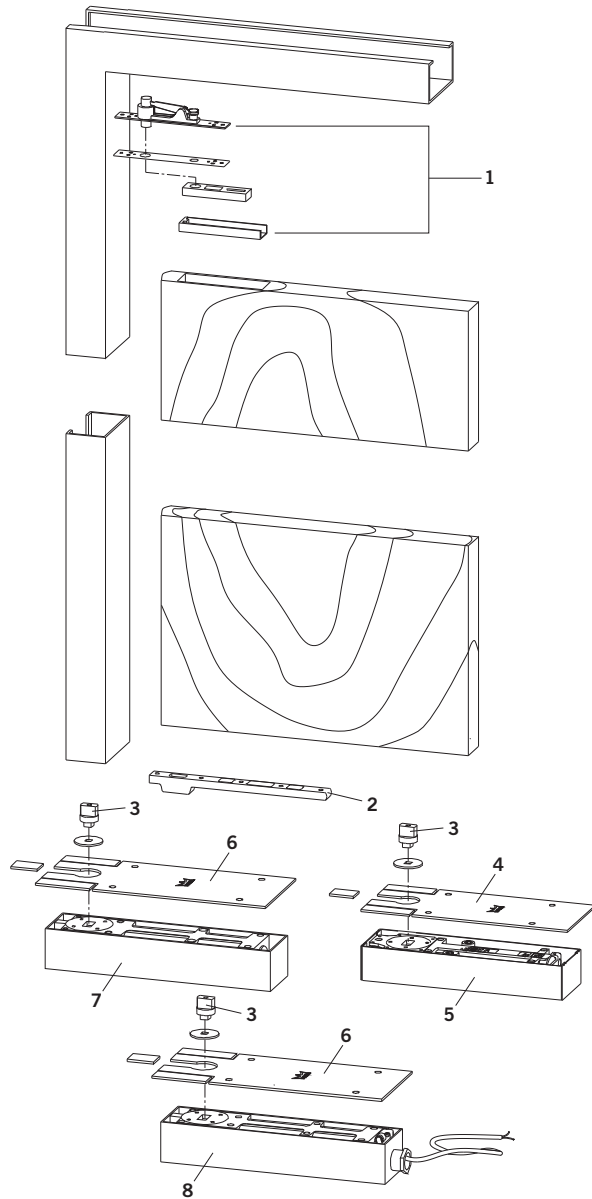

BTS 75V Packages

Components	BTS 75V/B - Center Hung, Double-Acting	BTS 75V/H - Center Hung, Single-Acting
1. Top Pivot	8062	8062
2. Bottom Arm	7421	7421
3. Spindle	74010	80010
4. Cover Plate	7510	7510
5. Closer and Cement Case	BTS 75V	BTS 75V

BTS 80 Packages

Components	BTS 80/B - Center Hung, Double-Acting	BTS 80/H - Center Hung, Single-Acting
1. Top Pivot	8062	8062
2. Bottom Arm	7421	7421
3. Spindle	74010	80010
6. Cover Plate	7410	7410
7. Closer and Cement Case	BTS 80	BTS 80

BTS 80 EMB Package

Components	BTS 80 EMB/H - Center Hung, Single-Acting
1. Top Pivot	8062
2. Bottom Arm	7421
3. Spindle	80010
6. Cover Plate	7410
8. Closer and Cement Case	BTS 80 EMB

Specify hand for H packages.

3/4" Offset Hung - Single Acting

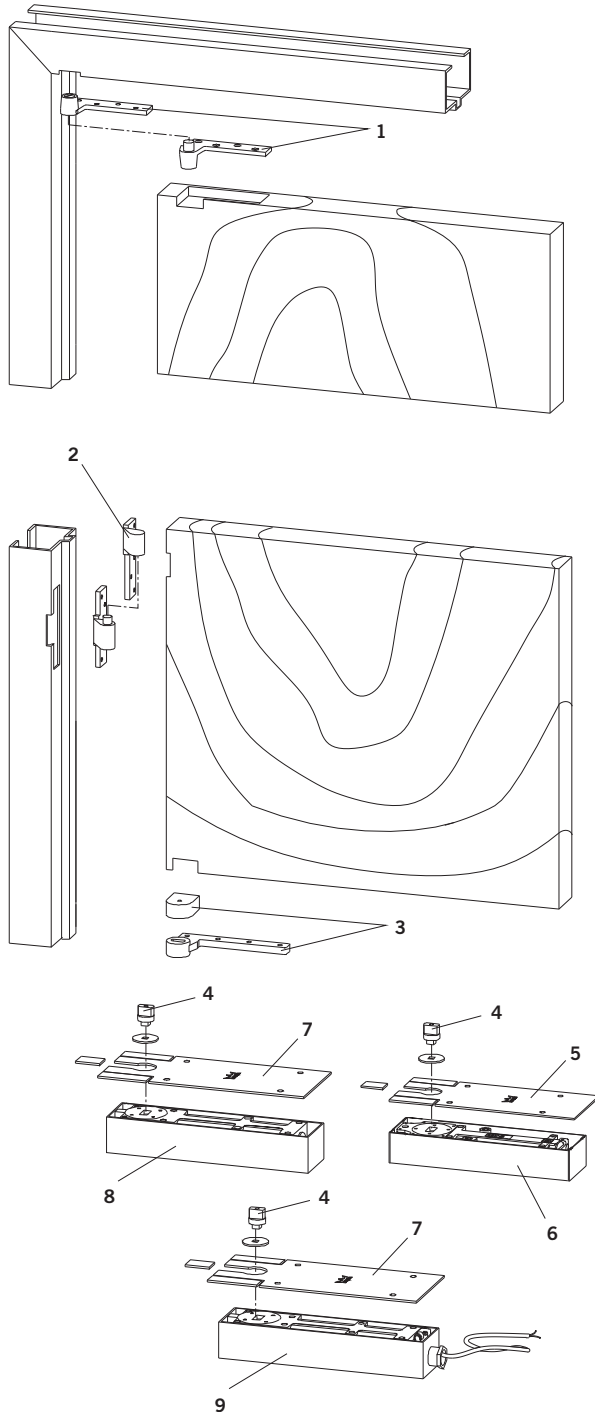

BTS 75V Packages			
Components	BTS 75V/D - 3/4" Offset, Standard	BTS 75V/E - 3/4" Offset, 20-Min Rated	BTS 75V/F - 3/4" Offset, Up to 3-Hr Rated
1. Top Pivot	75120	75122	75133
2. Intermediate Pivot	75220 (optional)	75222 (required)	75233 (required)
3. Bottom Arm	75323	75323	75323
4. Spindle	74010	74010	74010
5. Cover Plate	7510	7510	7510
6. Closer and Cement Case	BTS 75V	BTS 75V NHO	BTS 75V NHO

BTS 80 Packages			
Components	BTS 80/D - 3/4" Offset, Standard	BTS 80/E - 3/4" Offset, 20-Min Rated	BTS 80/F - 3/4" Offset, Up to 3-Hr Rated
1. Top Pivot	75120	75122	75133
2. Intermediate Pivot	75220 (optional)	75222 (required)	75233 (required)
3. Bottom Arm	75323	75323	75323
4. Spindle	74010	74010	74010
7. Cover Plate	7410	7410	7410
8. Closer and Cement Case	BTS 80	BTS 80F NHO	BTS 80F NHO

BTS 80 EMB Packages			
Components	BTS 80 EMB/D - 3/4" Offset, Standard	BTS 80 EMB/E - 3/4" Offset, 20-Min Rated	BTS 80 EMB/F - 3/4" Offset, Up to 3-Hr Rated
1. Top Pivot	75120	75122	75133
2. Intermediate Pivot	75220 (optional)	75222 (required)	75233 (required)
3. Bottom Arm	75323	75323	75323
4. Spindle	74010	74010	74010
7. Cover Plate	7410	7410	7410
9. Closer and Cement Case	BTS 80 EMB	BTS 80 EMB	BTS 80 EMB

NFPA 80 requires that labeled fire doors up to 60" in height be provided with 2 pivots and an additional pivot for each 30" of door height or fraction thereof. The same recommendation applies to non-labeled doors. Distance between pivots may exceed 30" on non-labeled doors.

Specify hand for D, E, and F packages.

1-1/2" Offset Hung - Single Acting

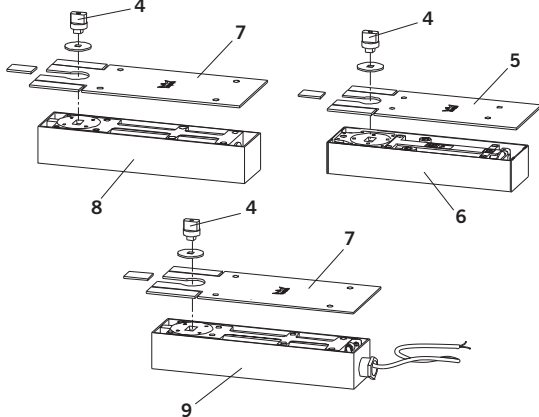
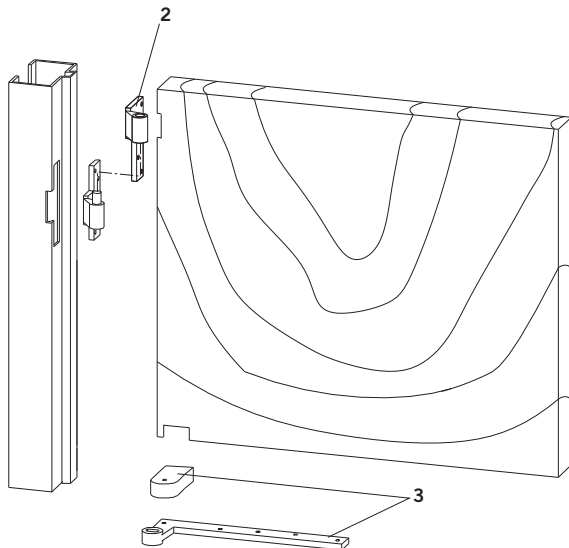
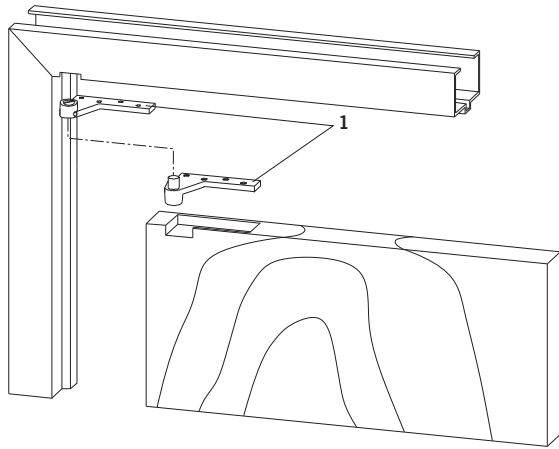

It is recommended that doors up to 60" in height be provided with two pivots and an additional pivot for each 30" of door height or fraction thereof. Distance between pivots may exceed 30" on non-labeled doors.

BTS 75V Packages			
Components	BTS 75V/C - 1-1/2" Offset, Standard	BTS 75V/CE - 1-1/2" Offset, 20-Min Rated	BTS 75V/CF - 1-1/2" Offset, Up to 3-Hr Rated
1. Top Pivot	15120	15122	15133
2. Intermediate Pivot	15220 (optional)	15222 (required)	15233 (required)
3. Bottom Arm	15323	15323	15323
4. Spindle	74010	74010	74010
5. Cover Plate	7510	7510	7510
6. Closer and Cement Case	BTS 75V	BTS 75V NHO	BTS 75V NHO

BTS 80 Packages			
Components	BTS 80/C - 1-1/2" Offset, Standard	BTS 80/CE - 1-1/2" Offset, 20-Min Rated	BTS 80/CF - 1-1/2" Offset, Up to 3-Hr Rated
1. Top Pivot	15120	15122	15133
2. Intermediate Pivot	15220 (optional)	15222 (required)	15233 (required)
3. Bottom Arm	15323	15323	15323
4. Spindle	74010	74010	74010
7. Cover Plate	7410	7410	7410
8. Closer and Cement Case	BTS 80	BTS 80F NHO	BTS 80F NHO

BTS 80 EMB Packages			
Components	BTS 80 EMB/C - 1-1/2" Offset, Standard	BTS 80 EMB/CE - 1-1/2" Offset, 20-Min Rated	BTS 80 EMB/CF - 1-1/2" Offset, Up to 3-Hr Rated
1. Top Pivot	15120	15122	15133
2. Intermediate Pivot	15220 (optional)	15222 (required)	15233 (required)
3. Bottom Arm	15323	15323	15323
4. Spindle	74010	74010	74010
7. Cover Plate	7410	7410	7410
9. Closer and Cement Case	BTS 80 EMB	BTS 80 EMB	BTS 80 EMB

Specify hand for C, CE, and CF packages.

Lead-Lined Door 3/4" Offset Hung - Single Acting

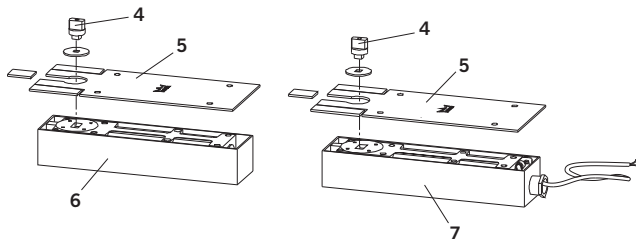
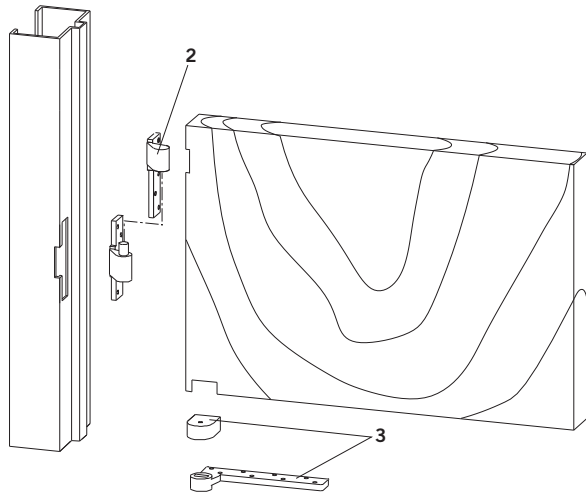
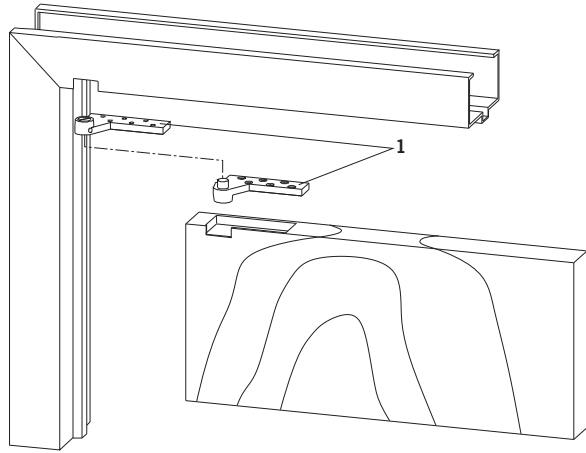

BTS 80 Packages			
Components	BTS 80/L - 3/4" Offset, Lead-Lined, Standard	BTS 80/LE - 3/4" Offset, Lead-Lined, 20-Min Rated	BTS 80/LF - 3/4" Offset, Lead Lined, Up to 3-Hr Rated
1. Top Pivot	75140	75142	75143
2. Intermediate Pivot	75240 (optional)	75242 (required)	75243 (required)
3. Bottom Arm	75343	75343	75343
4. Spindle	74010	74010	74010
5. Cover Plate	7410	7410	7410
6. Closer and Cement Case	BTS 80	BTS 80F NHO	BTS 80F NHO

BTS 80 EMB Packages			
Components	BTS 80 EMB/L - 3/4" Offset, Lead-Lined, Standard	BTS 80 EMB/LE - 3/4" Offset, Lead-Lined, 20-Min Rated	BTS 80 EMB/LF - 3/4" Offset, Lead Lined, Up to 3-Hr Rated
1. Top Pivot	75140	75142	75143
2. Intermediate Pivot	75240 (optional)	75242 (required)	75243 (required)
3. Bottom Arm	75343	75343	75343
4. Spindle	74010	74010	74010
5. Cover Plate	7410	7410	7410
7. Closer and Cement Case	BTS 80 EMB	BTS 80 EMB	BTS 80 EMB

It is recommended that doors up to 60" in height shall be provided with two pivots and an additional pivot for each 30" of door height or fraction thereof. Distance between pivots may exceed 30" on non-labeled doors.

Specify hand for L, LE, and LF packages.

Independently Hung Doors

Packages have been developed for use with 4-1/2" wide butt hinges. Applications using alternate hanging means should be submitted to DORMA's Technical Services Department for review and recommendation.

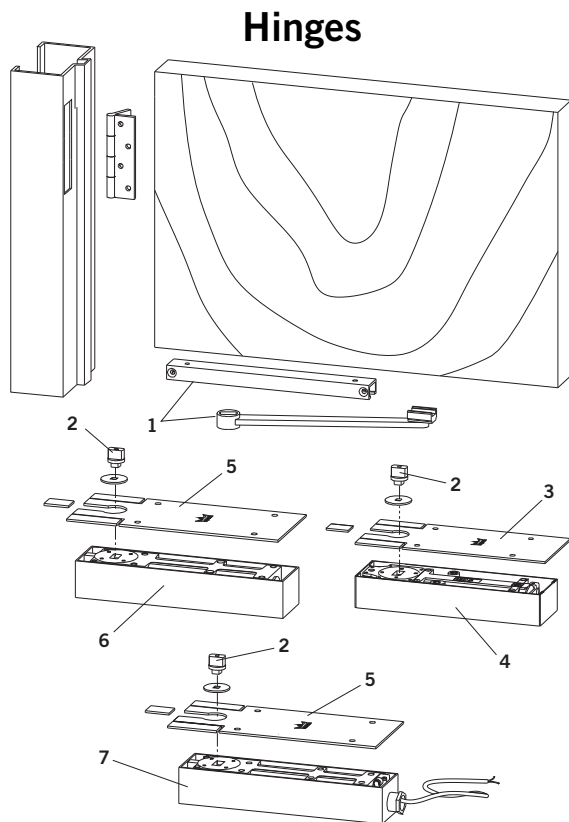

BTS 75V Packages		
	BTS 75V/I - Standard	BTS 75V/IF - 3-Hr Rated Steel, 1-1/2-Hr Rated Wood
Components		
1. Slide Arm Assembly	7451N	7451N
2. Spindle	74003	74003
3. Cover Plate	7510	7510
4. Closer and Cement Case	BTS 75V	BTS 75V NHO

BTS 80 Packages		
	BTS 80/I - Standard	BTS 80/IF - 3-Hr Rated Steel, 1-1/2-Hr Rated Wood
Components		
1. Slide Arm Assembly	7451N	7451N
2. Spindle	74003	74003
5. Cover Plate	7410	7410
6. Closer and Cement Case	BTS 80	BTS 80F NHO

BTS 80 EMB Packages		
	BTS 80 EMB/I - Standard	BTS 80 EMB/IF - 3-Hr Rated Steel, 1-1/2-Hr Rated Wood
Components		
1. Slide Arm Assembly	7451N	7451N
2. Spindle	74003	74003
5. Cover Plate	7410	7410
7. Closer and Cement Case	BTS 80 EMB	BTS 80 EMB

- I packages mortise the track in the bottom of the door.
- I packages can be installed on the push or pull side of an opening.
- IF packages surface apply the track to the face of the door.

Specify hand for EMB/I and EMB/IF packages.

Independently Hung Doors

Packages have been developed for use with pocket pivots. Applications using alternate hanging means should be submitted to DORMA's Technical Services Department for review and recommendation.

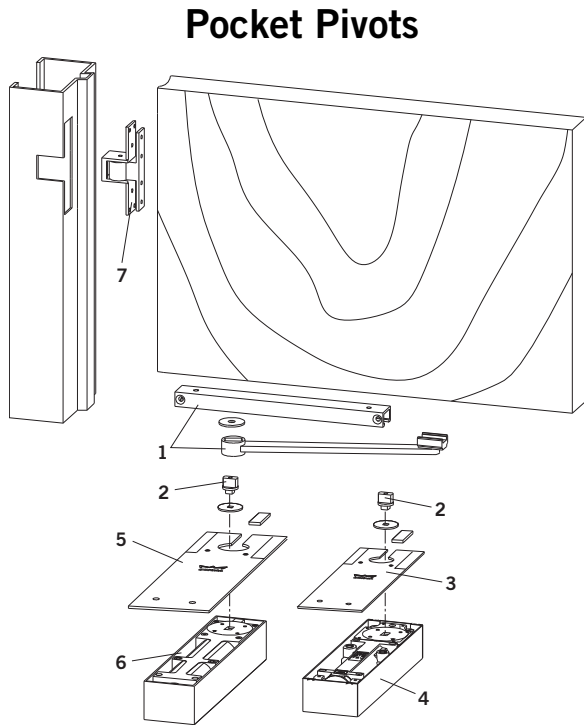

BTS 75V Packages		
	BTS 75V/P - Standard	BTS 75V/PF - 3-Hr Rated Steel, 20-Min Rated Wood
Components		
1. Slide Arm Assembly	7451N	7451N
2. Spindle	74003	74003
3. Cover Plate	7510	7510
4. Closer and Cement Case	BTS 75V	BTS 75V NHO
7. Pocket Pivot	75520	75523

BTS 80 Packages		
	BTS 80/P - Standard	BTS 80/PF - 3-Hr Rated Steel, 20-Min Rated Wood
Components		
1. Slide Arm Assembly	7451N	7451N
2. Spindle	74003	74003
5. Cover Plate	7410	7410
6. Closer and Cement Case	BTS 80	BTS 80F NHO
7. Pocket Pivot	75520	75523

- P packages mortise the track in the bottom of the door.
- PF packages surface apply the track to the face of the door.
- P and PF packages have three pocket pivots for doors up to 7'-6" tall. Taller doors should use an additional pivot for every 30" of door height or fraction thereof.

Specify hand for P and PF packages.

Accessories for Center Hung Installations

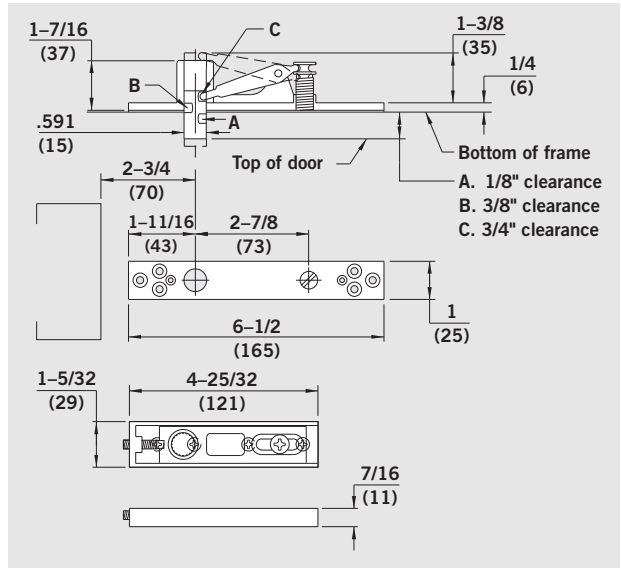
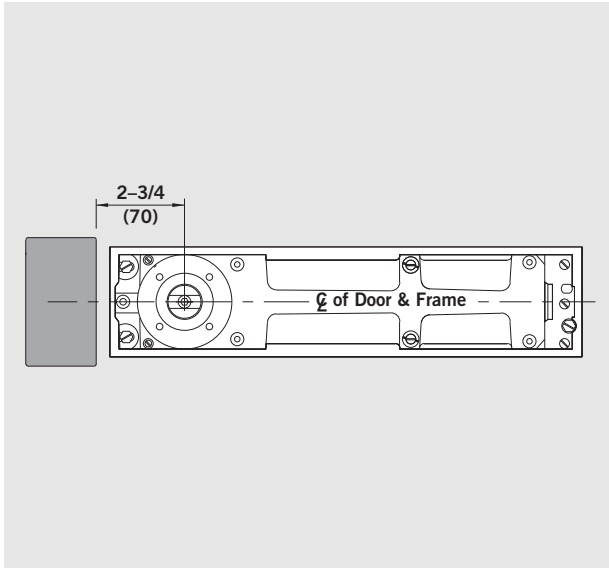

No. 8062 — Walking beam top pivot with cover plate. Adjustable to obtain top door clearances of 1/8", 3/8" or 3/4". Optional extended pin available for clearances of 3/4", 1" or 1-5/16".

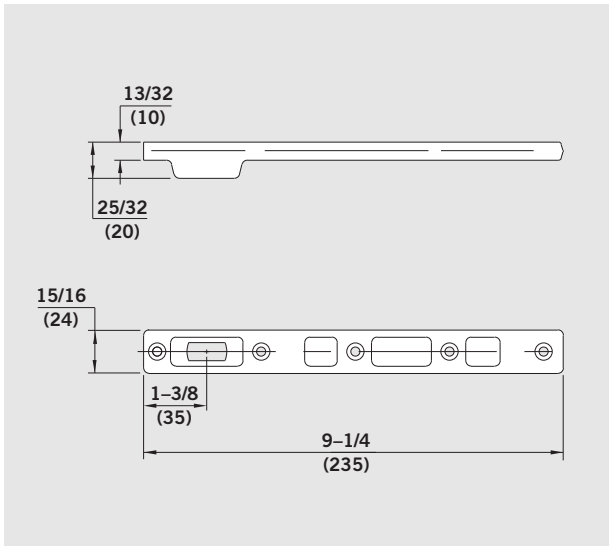

No. 7421 — Center hung bottom arm for steel or wood doors.

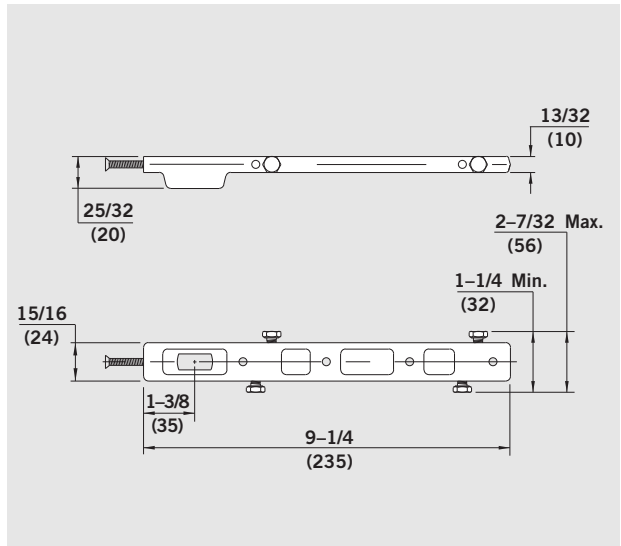

No. 7422 — Center hung bottom arm for aluminum doors.

Accessories for 3/4" Offset Installations

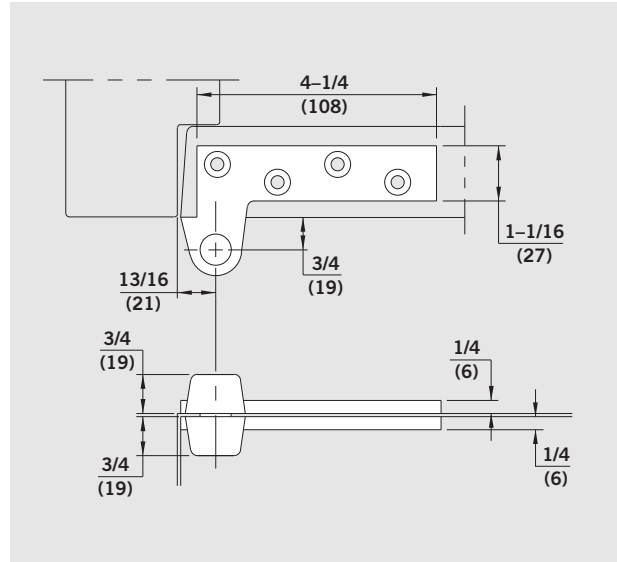
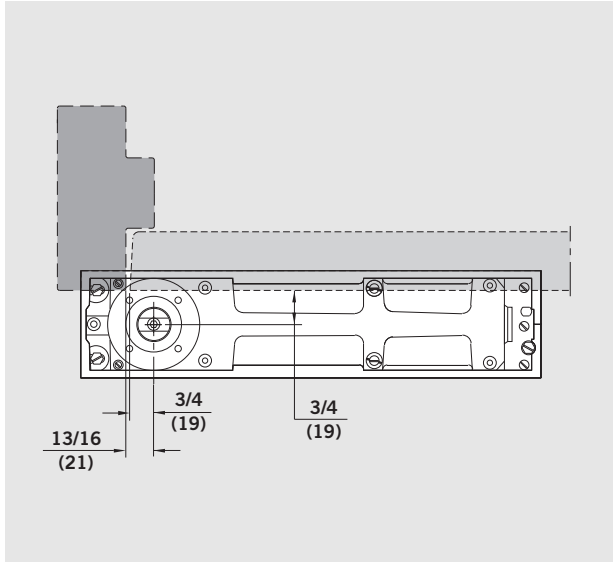

- No. 75120** — 3/4" offset brass top pivot.
- No. 75122** — 3/4" offset brass top pivot.
U.L. listed for 20-minute rated fire doors.
- No. 75133** — 3/4" offset steel top pivot.
For use on fire doors rated up to three hours.

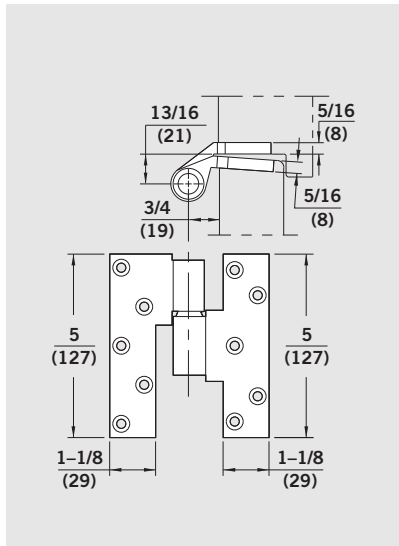

- No. 75220** — 3/4" offset standard-duty brass intermediate pivot.
- No. 75222** — 3/4" offset standard-duty brass intermediate pivot. U.L. listed for 20-minute rated fire doors.
- No. 75233** — 3/4" offset heavy-duty steel intermediate pivot. For use on fire doors rated up to three hours.
(Specify Hand)

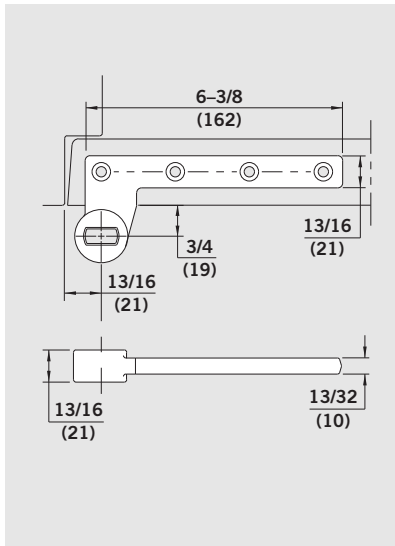

- No. 75323** — 3/4" offset standard-duty steel bottom arm. Can also be used on fire doors rated up to three hours.
(Specify Hand)

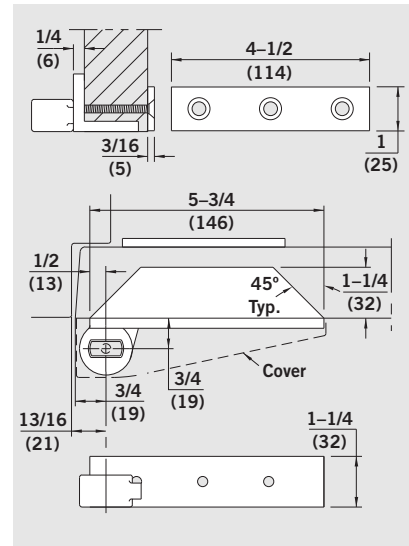

- No. 75353** — 3/4" offset steel bottom arm. Closer is removable without removing door. Intermediate pivots are required when using this arm.
(Specify Hand)

Accessories for 1-1/2" Offset Installations

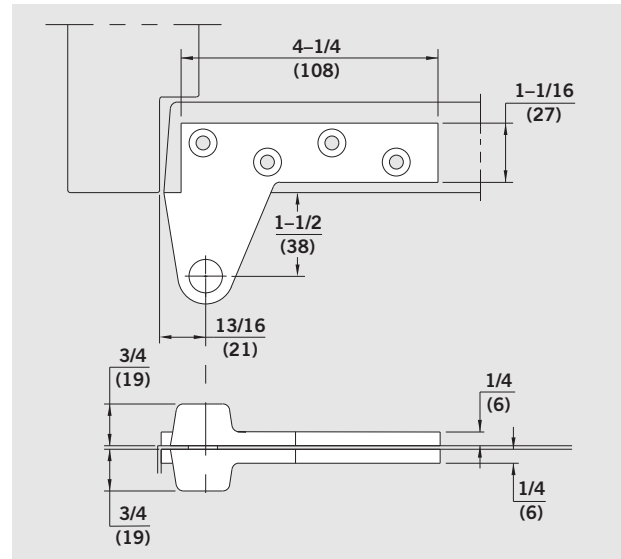
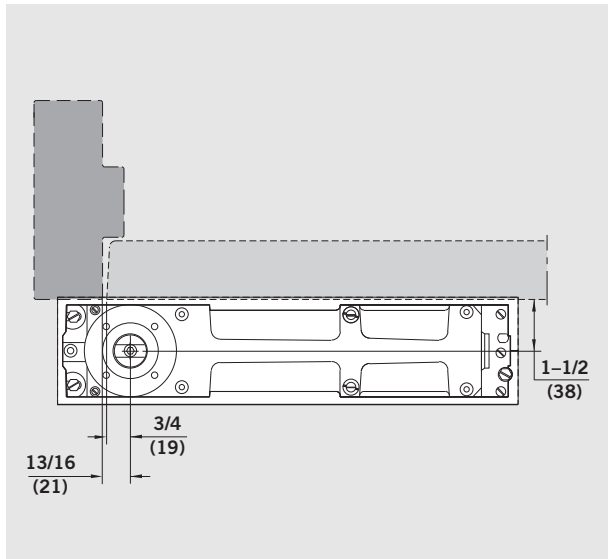

No. 15120 — 1-1/2" offset brass top pivot.

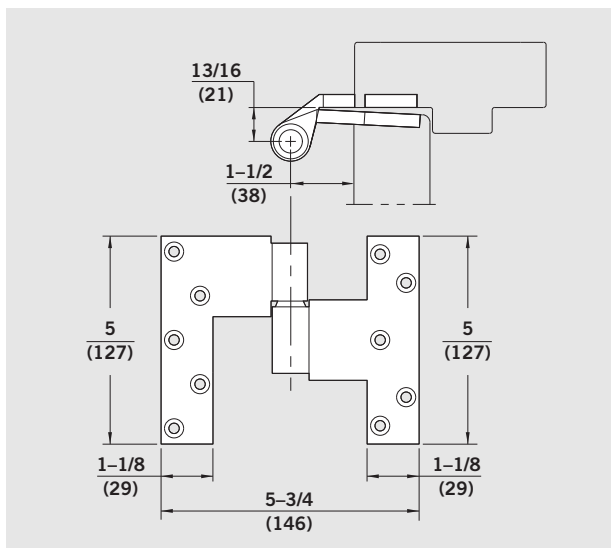

No. 15220 — 1-1/2" offset brass intermediate pivot.
(Specify Hand)

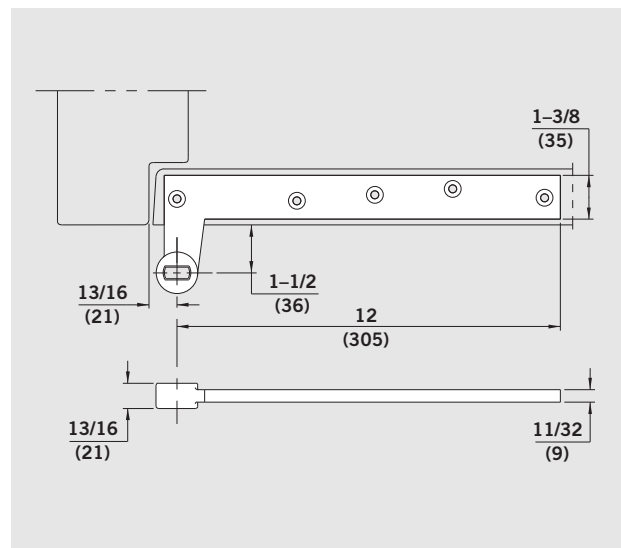

No. 15323 — 1-1/2" offset steel bottom arm.
(Specify Hand)

Accessories for 3/4" Offset Lead-Lined Installations

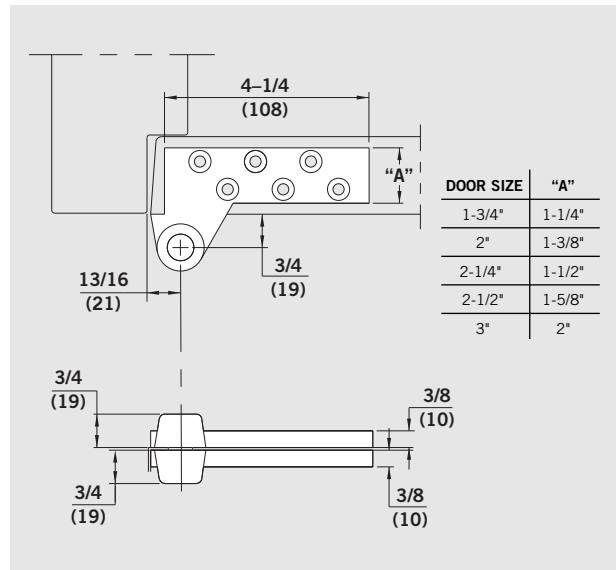
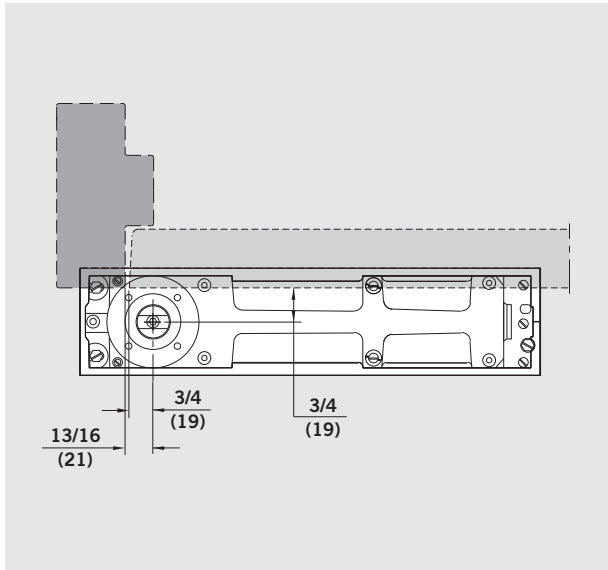

No. 75140 — 3/4" offset brass top pivot for lead-lined doors 1-3/4" thick.

Note: For doors 2" to 3" thick specify as follows:

No. 75140-2 — For use on doors 2" thick.

No. 75140-2-1/4 — For use on doors 2-1/4" thick.

No. 75140-2-1/2 — For use on doors 2-1/2" thick.

No. 75140-3 — For use on doors 3" thick.

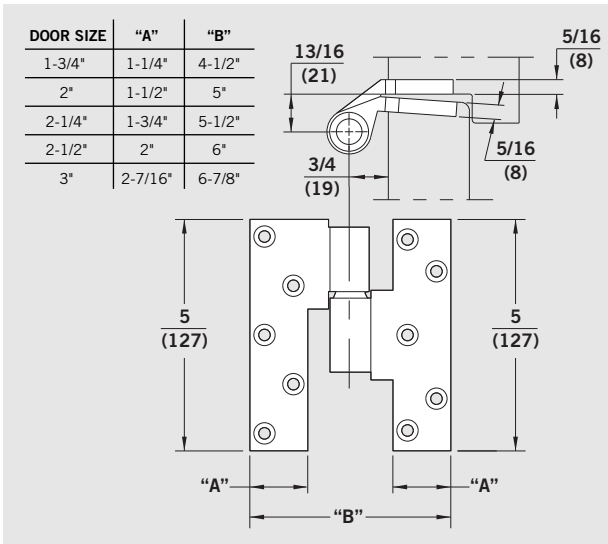

No. 75240 — 3/4" offset brass intermediate pivot for lead-lined doors 1-3/4" thick.

Note: For doors 2" to 3" thick specify as follows:

No. 75240-2 — For use on doors 2" thick.

No. 75240-2-1/4 — For use on doors 2-1/4" thick.

No. 75240-2-1/2 — For use on doors 2-1/2" thick.

No. 75240-3 — For use on doors 3" thick.

(Specify Hand)

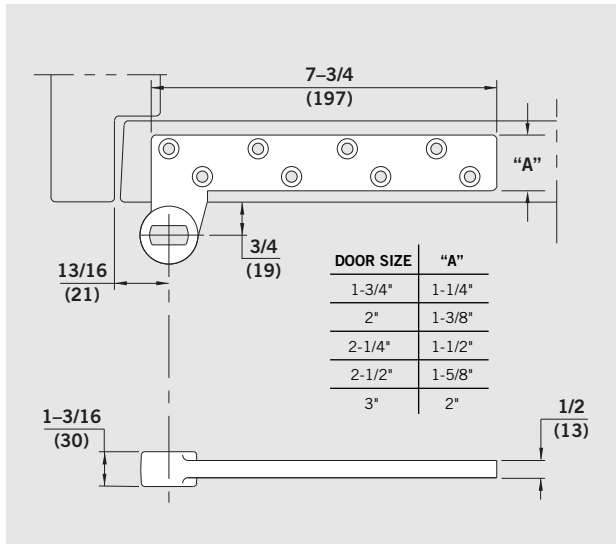

No. 75343 — 3/4" offset steel bottom arm for lead-lined 1-3/4" doors.

Note: For doors 2" to 3" thick specify as follows:

No. 75343-2 — For use on doors 2" thick.

No. 75343-2-1/4 — For use on doors 2-1/4" thick.

No. 75343-2-1/2 — For use on doors 2-1/2" thick.

No. 75343-3 — For use on doors 3" thick.

(Specify Hand)

Accessories for Independently Hung Installations

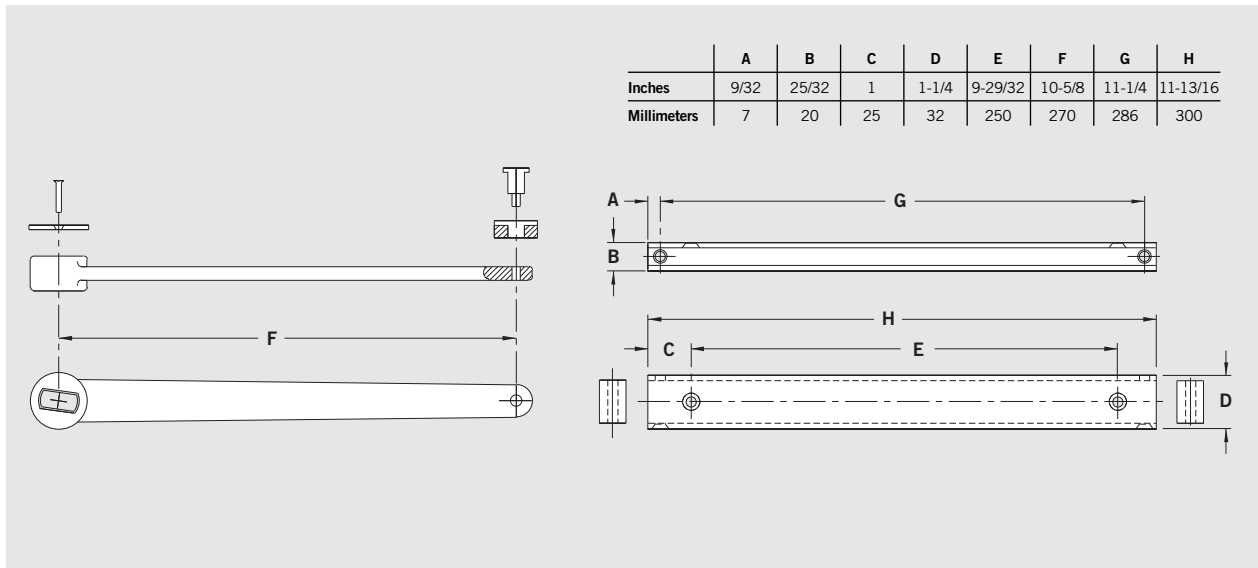

No. 7451N Slide Arm and Channel — Drop forged steel with nylon slide block, cover washer, and anodized aluminum channel.

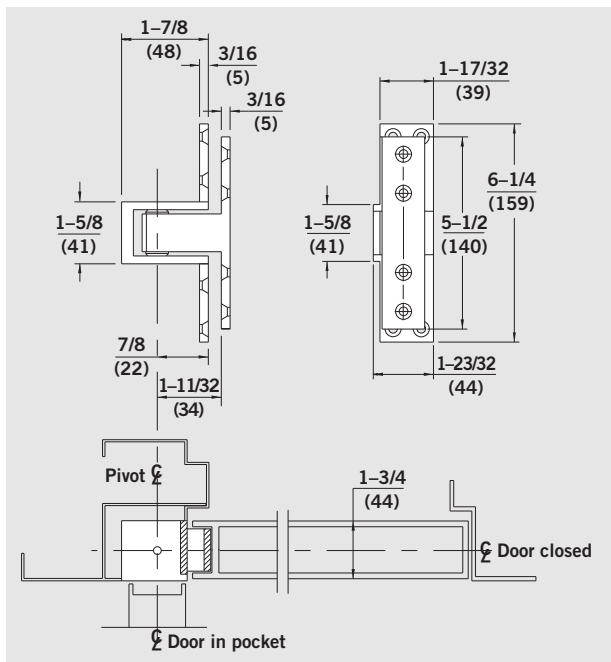

No. 75520 — Brass pocket pivot. For 90° pocket doors.

No. 75523 — Steel pocket pivot for 90° pocket doors.

U.L. listed for 20 minute wood doors and 3 hour rated steel fire doors.

(Specify Hand)

Terrazzo Pan

BTS 75V Series

- **TP 75V CH** for center hung applications (shown).
- **TP 75V RH** or **LH** for 3/4" offset applications (specify hand).

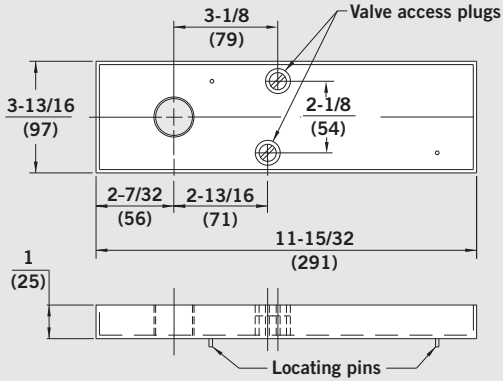

BTS 80/BTS 80 EMB Series

- **TP 80 CH** for center hung applications (shown).
- **TP 80 RH** or **LH** for 3/4" offset applications (specify hand).

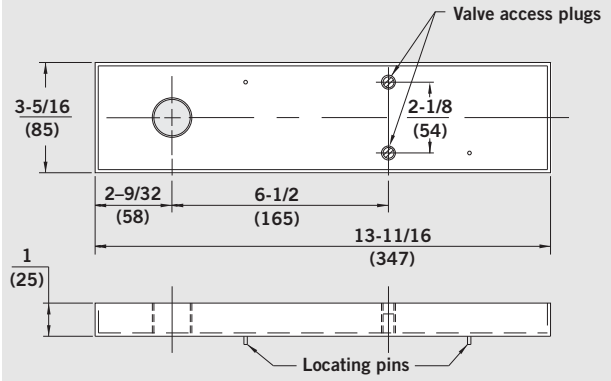

Made from stainless steel and used in lieu of standard floor plate. Offers uninterrupted appearance with terrazzo or marble. Shims are included to allow easy removal of pan after initial installation.

Note: When calculating the spindle size to be used with a terrazzo pan application, add 1" to the desired clearance between the door and the finished floor.

Cover Plate

The BTS 75V universal cover plate **7510**, suitable for left hand/right hand, 3/4" offset, 1-1/2" offset, and center pivoted doors.

	G	H	I	J
Inches	4-1/8	12-1/8	2-9/32	3/32
Millimeters	105	308	58	2

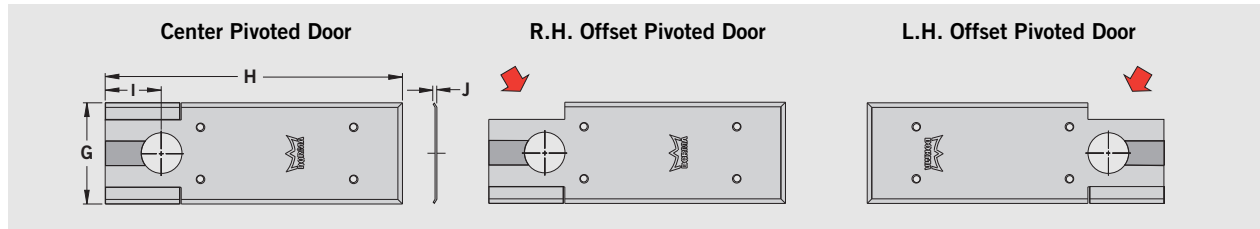

The BTS 80 and BTS 80 EMB universal cover plate **7410**, suitable for left hand/right hand, 3/4" offset, 1-1/2" offset, and center pivoted doors.

	G	H	I	J
Inches	4-1/8	14-3/32	2-9/32	3/32
Millimeters	105	358	58	2

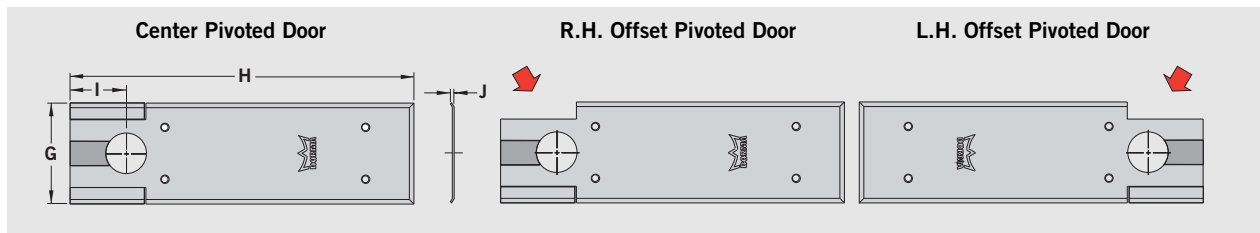

Spindles			
Spindle No.	Dimension "x" (Door Clearance)	3° Pre-load Spindle No.	Dimension "y"
74003	5/16"	80003	1/8"
74005	1/2"	80005	5/16"
74007	5/8"	-	7/16"
(STD) 74010	3/4"	80010	1/2"
74012	13/16"	-	5/8"
74015	7/8"	80015	11/16"
74020	1-1/8"	80020	7/8"
74025	1-5/16"	80025	1"
74030	1-1/2"	80030	1-5/16"
74035	1-11/16"	-	1-1/2"
74040	1-7/8"	-	1-11/16"
74045	2-1/16"	-	1-7/8"
74050	2-5/16"	-	2-1/16"

Extended Spindle Insert
NOTE: Closer and arm must be installed per template for door clearances shown to be valid.

Closers with extended spindle inserts are used with thresholds, carpeted floors, terrazzo pans or in cases where more clearance between door and floor is required. All spindles are zinc plated.

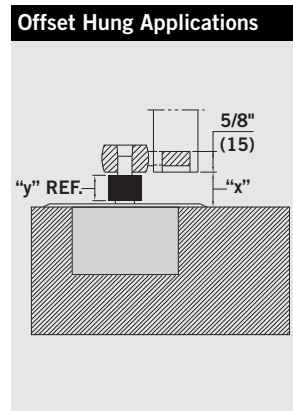
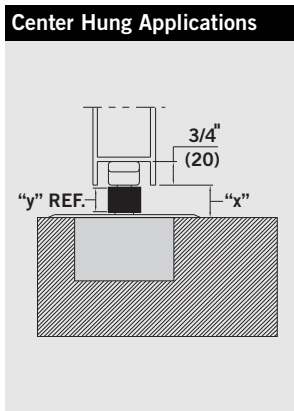

Pre-load Spindles
 Spindles are available with a 3° pre-load for additional pressure to hold door in the closed position. Normally, this is only necessary for center-pivoted single acting applications. However, they can also be used with other applications to compensate for templating errors. Specify hand of pre-load spindle when ordering.



DORMA Americas

www.dorma-usa.com

DORMA Architectural Hardware

DORMA Drive, Drawer AC
Reamstown, PA 17567-0411
Telephone: (800) 523-8483
Facsimile: (800) 274-9724
E-mail: archdw@dorma-usa.com

DORMA Glas

1520 Jabez Run, Suite 303
Millersville, MD 21108
Telephone: (800) 451-0649
Facsimile: (410) 923-3060
E-mail: glas@dorma-usa.com

DORMA Canada

1680 Courtney Park Drive, Unit 13
Mississauga, Ontario L5T 1R4
Telephone: (800) 387-4938
Facsimile: (905) 670-5850
E-mail: sales@dormacanada.com

DORMA Mexico, S. de R.L. de C.V.

Astrónomos 28, Col. Escandón
México, D.F. 11800
Del. Miguel Hidalgo
Telephone: (52+55) 5272-6937
Facsimile: (52+55) 5272-6948
E-mail: operacion@dorma.com.mx