



GYRO TECH™

by NABCO Entrances Inc.

Where quality and service are automatic

WWW.NABCOENTRANCES.COM

1-877-622-2694

JOB NAME: _____

LOCATION: _____

DISTRIBUTOR: _____

DOOR #: _____ DATE: _____

SHEET ____ OF ____

GT400-03

BOTTOM LOAD HEADER SIMULTANEOUS PAIR INSWING

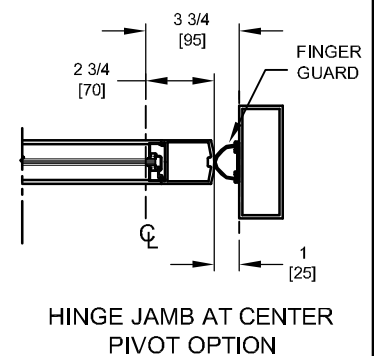
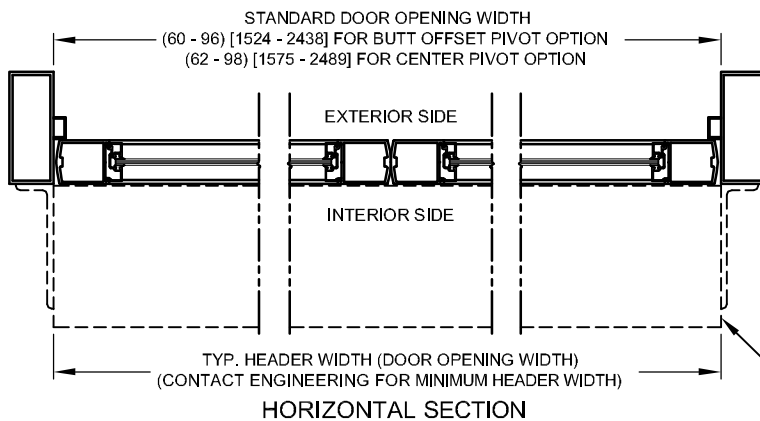
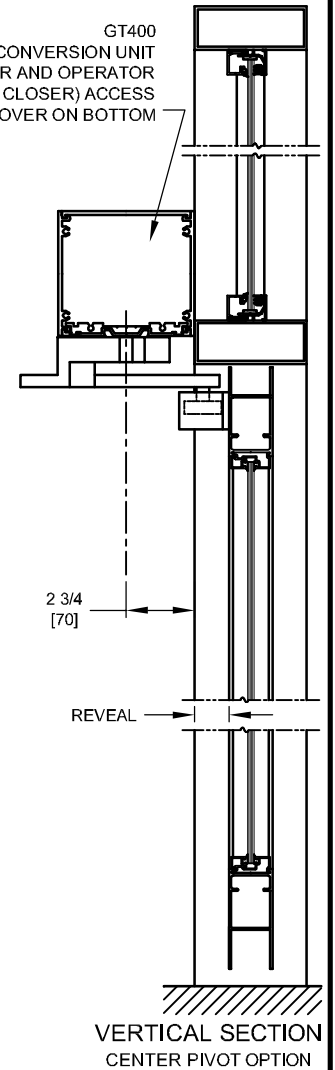
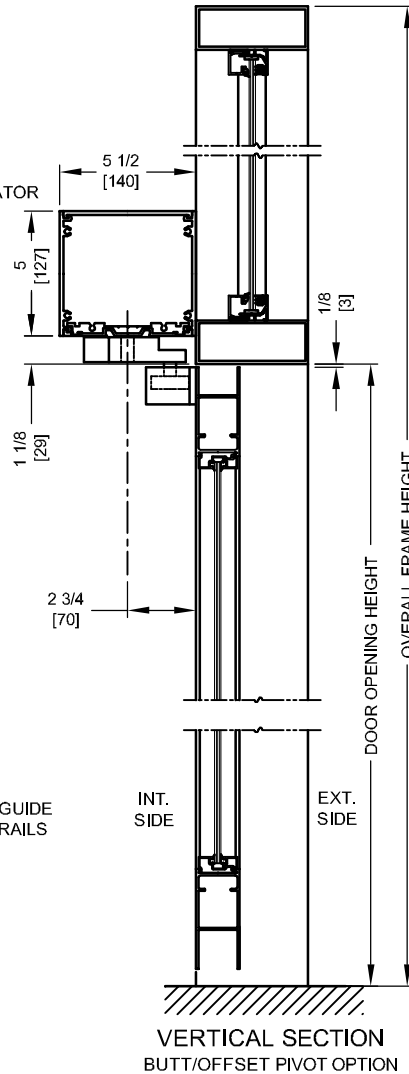
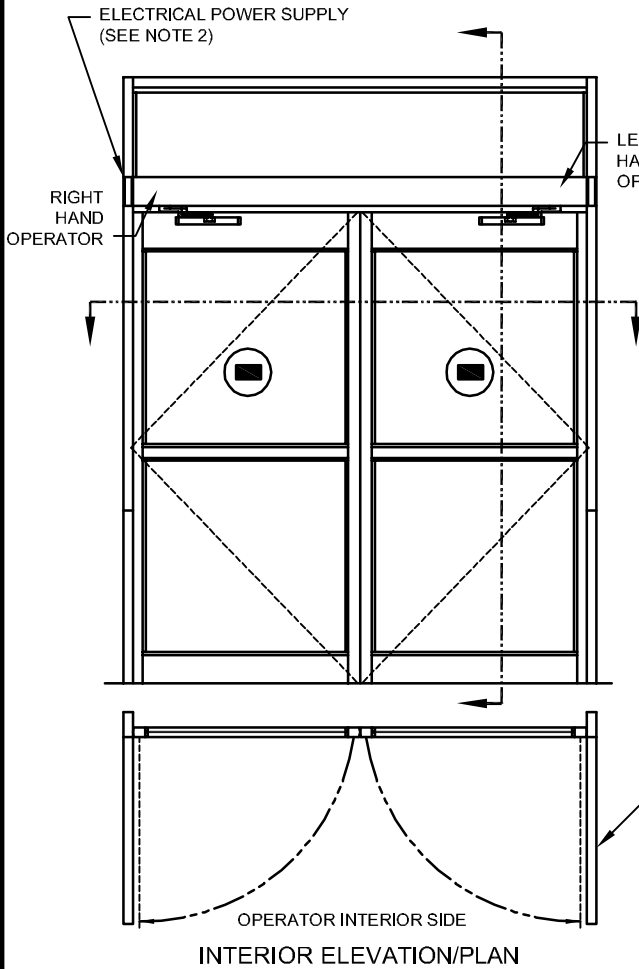

NOTES:

1. GUIDE RAILS, MATS, PUSH PLATES AND VARIOUS ELECTRONIC DEVICES FOR THE DOOR ACTIVATION AND CONTROL ARE OPTIONAL. CONSULT WITH YOUR NABCO/GYRO TECH DISTRIBUTOR.
2. POWER TO HEADER WILL BE 115VAC, 5 AMP PER OPERATOR PROVIDED BY ELECTRICAL CONTRACTOR.
3. STANDARD HARDWARE SUPPLIED WILL ACCOMMODATE DOOR THICKNESS OF 1 3/4" TO 2 1/4".
4. APPLICATION ON BALANCE DOORS REQUIRES RELOCATION OF THE OPERATOR PIVOT.
5. SPECIAL ARMS MAY BE REQUIRED ON INSWING DOORS WITH REVEAL GREATER THAN 1 3/4" AND OUTSWING DOORS WITH REVEAL GREATER THAN 16".