



Planning Manual
for
Horizontal Sliding
Walls

DORMA HSW/FSW

DORMA HSW – Transparent versatility

Horizontal sliding walls are used in a wide range of different project types, and for both internal and external applications. These partitions can be flexibly designed to suit the site of installation, structural conditions and design concept. They can satisfy a broad spectrum of requirements in relation to styling, material and finish or colour, and can also be equipped with individually fabricated panels to perform special functions. Additional utilisation of the DORMA substructure ensures flexible planning in the case of all system variants as well as providing for the simple installation, maximum reliability and outstanding safety of the entire system.

HSW Horizontal Sliding Walls

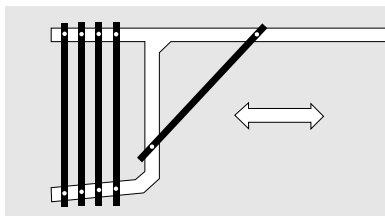

HSW-G
Fully glazed
with door rails

HSW-GP
Single-point fixings
with standard track rail

HSW-GE BOXes
All-glas with patch fittings

FSW Folding Sliding Walls

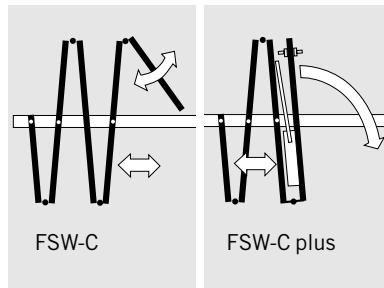
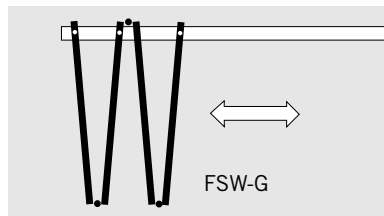

FSW-G
Fully glazed with door rails

FSW-C
Roller carrier position at door rail centre

FSW-C plus
Roller carrier position at door rail centre
plus full-width sliding folding panel

HSW Horizontal Sliding Walls, fully framed

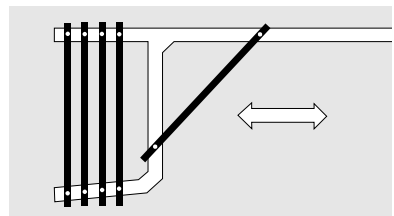

HSW-R
Fully framed for toughened safety glass,
laminated safety glass or double glazing

HSW-ISO
Fully framed with thermal-break frame
profiles

Contents

			Page
HSW Support and Guide Elements	1.0	1.1 Parking and Stacking	4 - 13
		Example stacking arrangements	
		Stacking track calculations	
		Niche parking	
		1.2 Track Rails	14 - 15
		1.3 Substructure	16 - 21
HSW / FSW Panel Types	2.0	2.1 HSW-G	24 - 33
		2.2 HSW-GP	34 - 37
		2.3 HSW-GE BOXes	38 - 47
		2.4 FSW-G	48 - 51
		2.5 FSW-C/C plus	52 - 57
		2.6 HSW-R	58 - 64
		2.7 HSW-ISO	66 - 72
Accessories	4.0	4.1 Vertical Seals Overview	74
		4.2 Vertical Seals	
		Fineline	75 - 80
		Line	81 - 84
		4.3 Floor Track	86 - 87
General Information	5.0	4.1 Measuring Up	88
		4.2 Portal Systems / Surface Finishes	89

Technical subjects to change without notice.

Stacking systems

Perfect parking every time

Existing structures or unusual layouts often require special solutions, particularly in the design of the stacking area. DORMA HSW systems can be parked in a range of different positions. The stack of panels can be aligned parallel or square to the frontage, be readily visible for effect or hidden behind columns etc.

Another possibility is that of parking the system in line but out of the way, whether behind a wall or in a niche (see also pages 5 - 13).

The panels can also perform certain functions when the frontage is open, such as providing the sides of internal store windows and showcases, or, if provided with the appropriate printing on the glass, for adding artistic value to a wall.

The following pages show some system solutions devised in answer to a wide range of different problems.



Panels stacked 90° transverse to travel direction

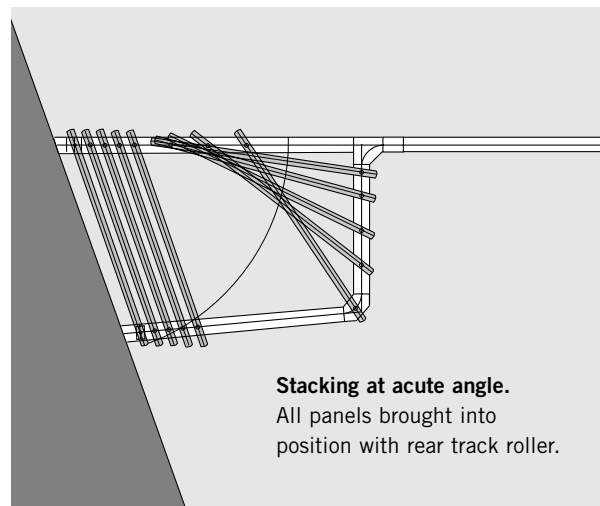
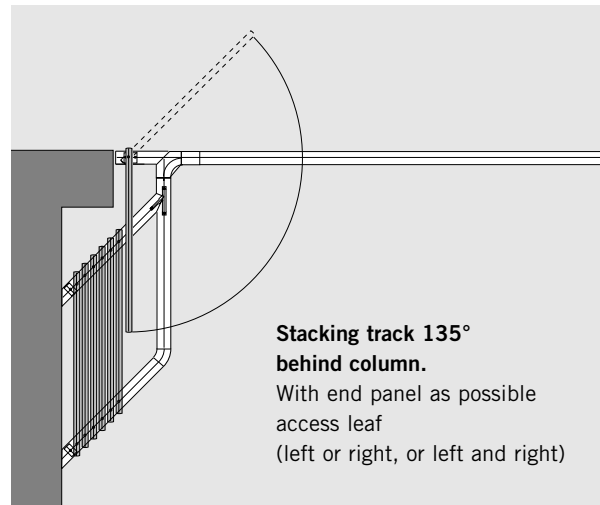
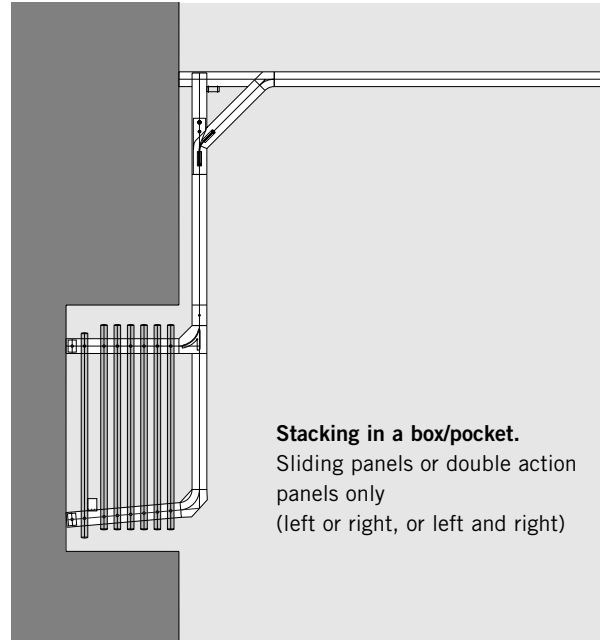
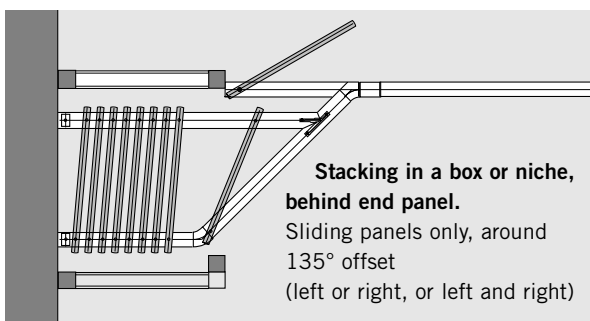
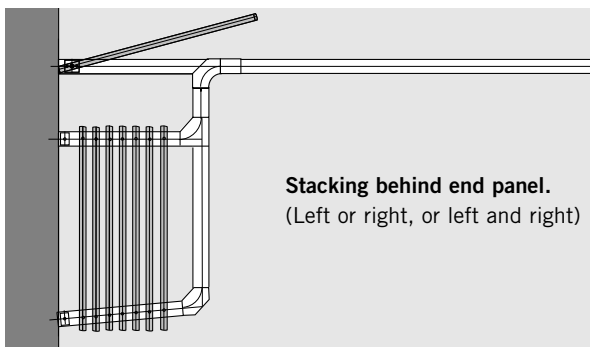
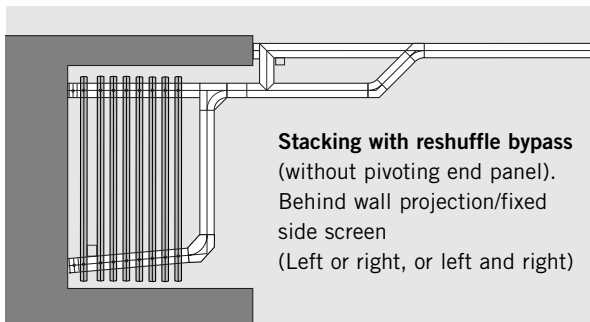
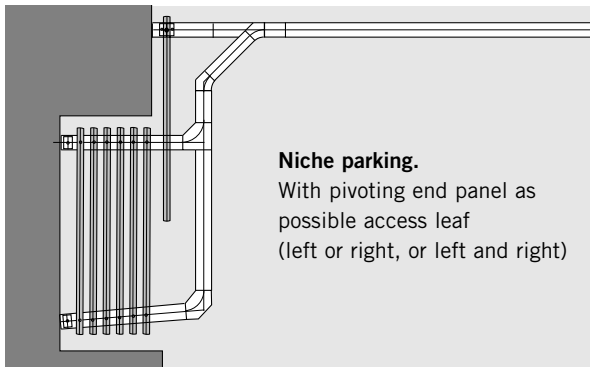
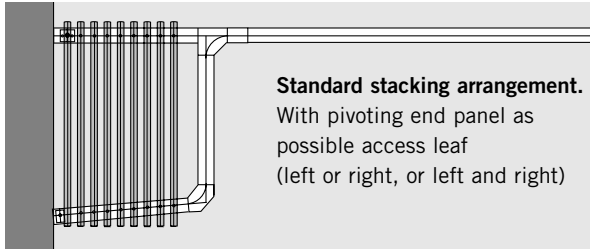

Panels parallel to travel direction

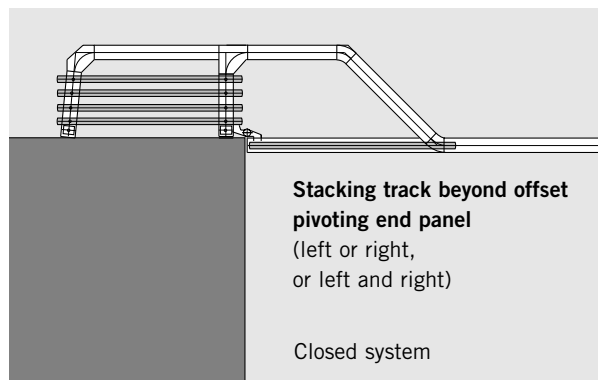
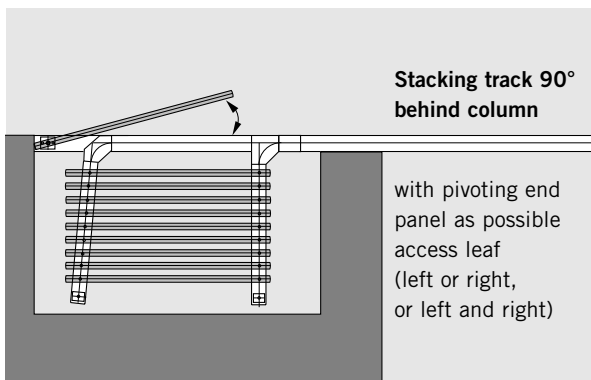
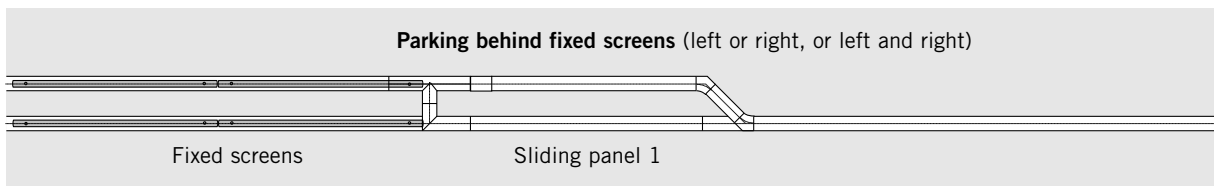
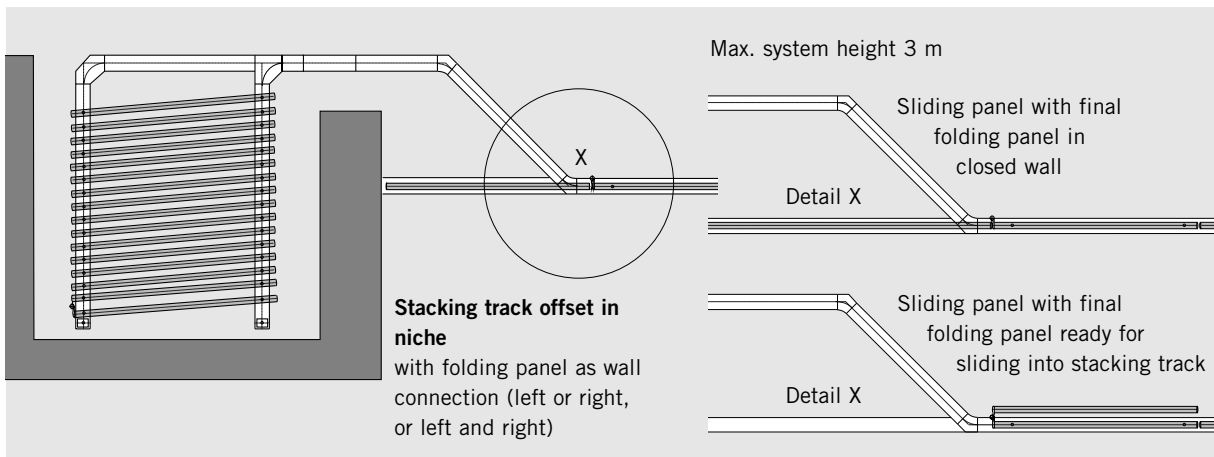
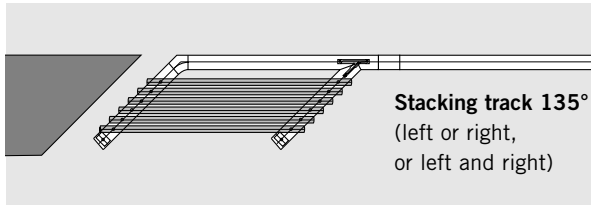
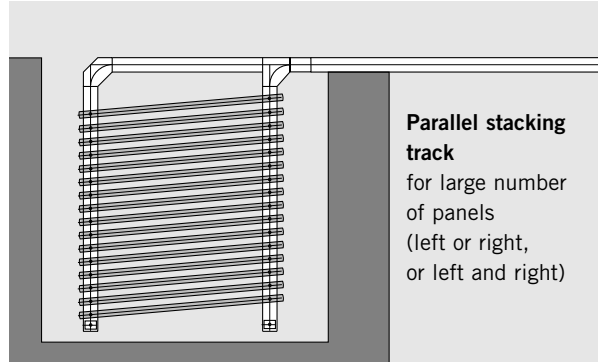
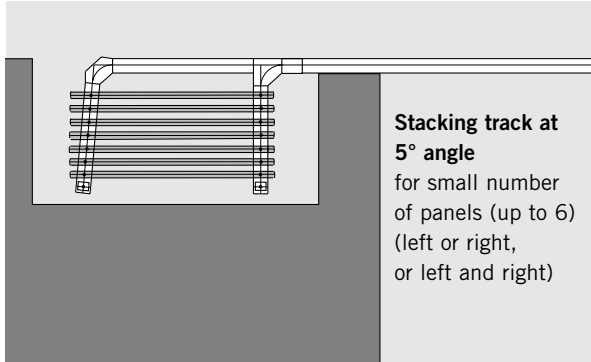

Special stacking arrangements

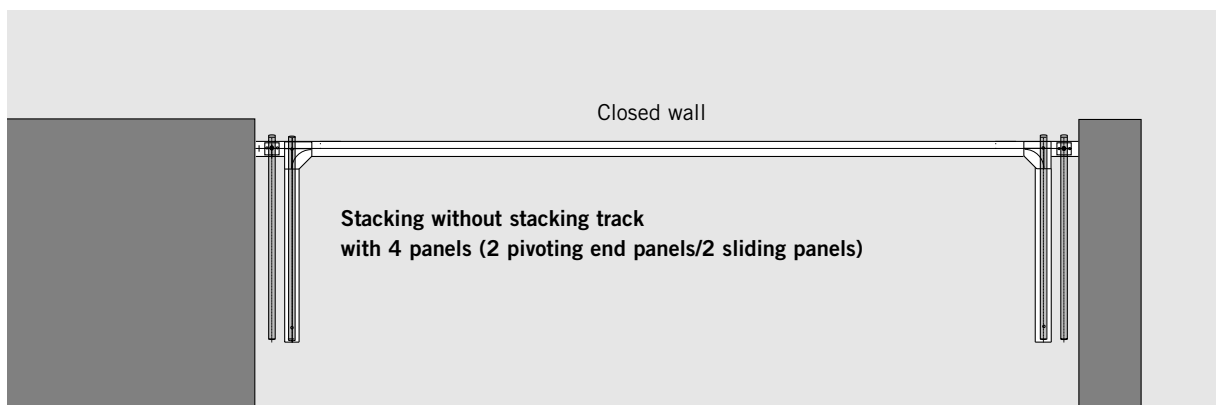
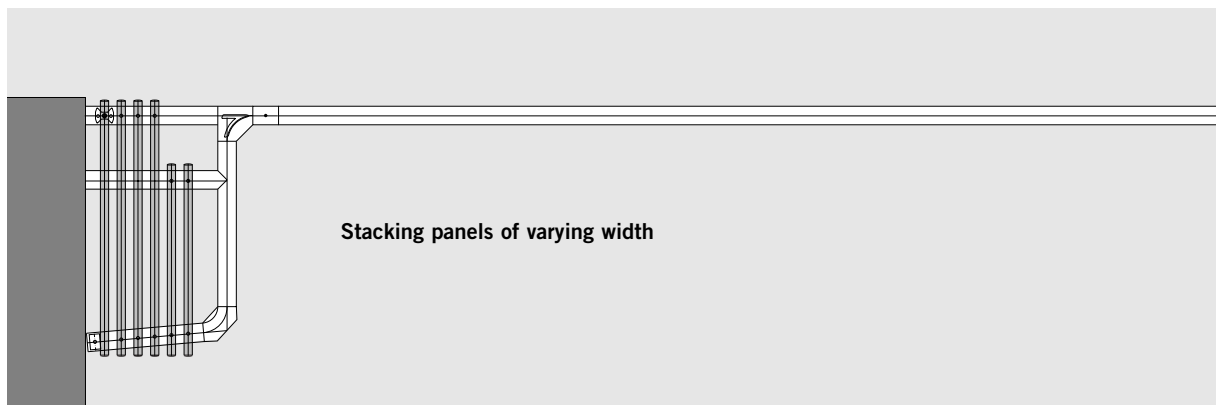
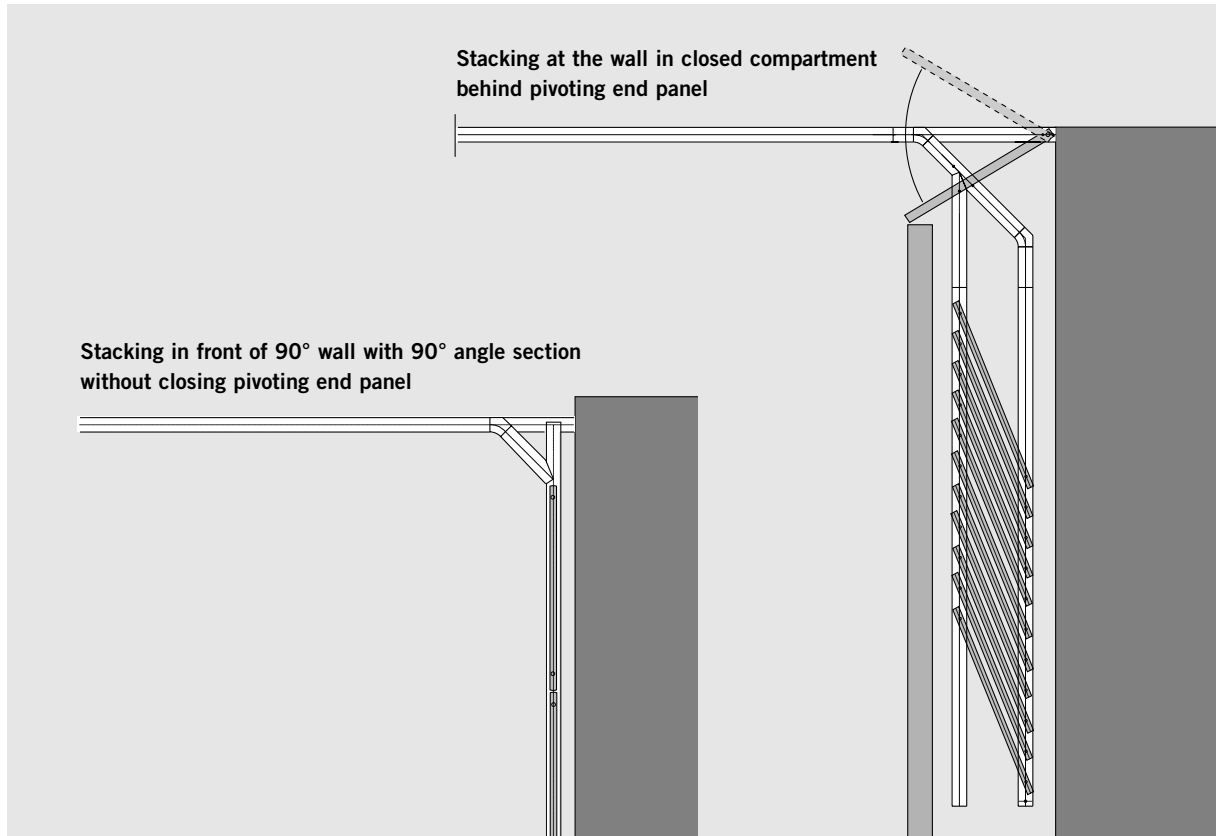

Straight track rail with stacking position transverse to travel direction

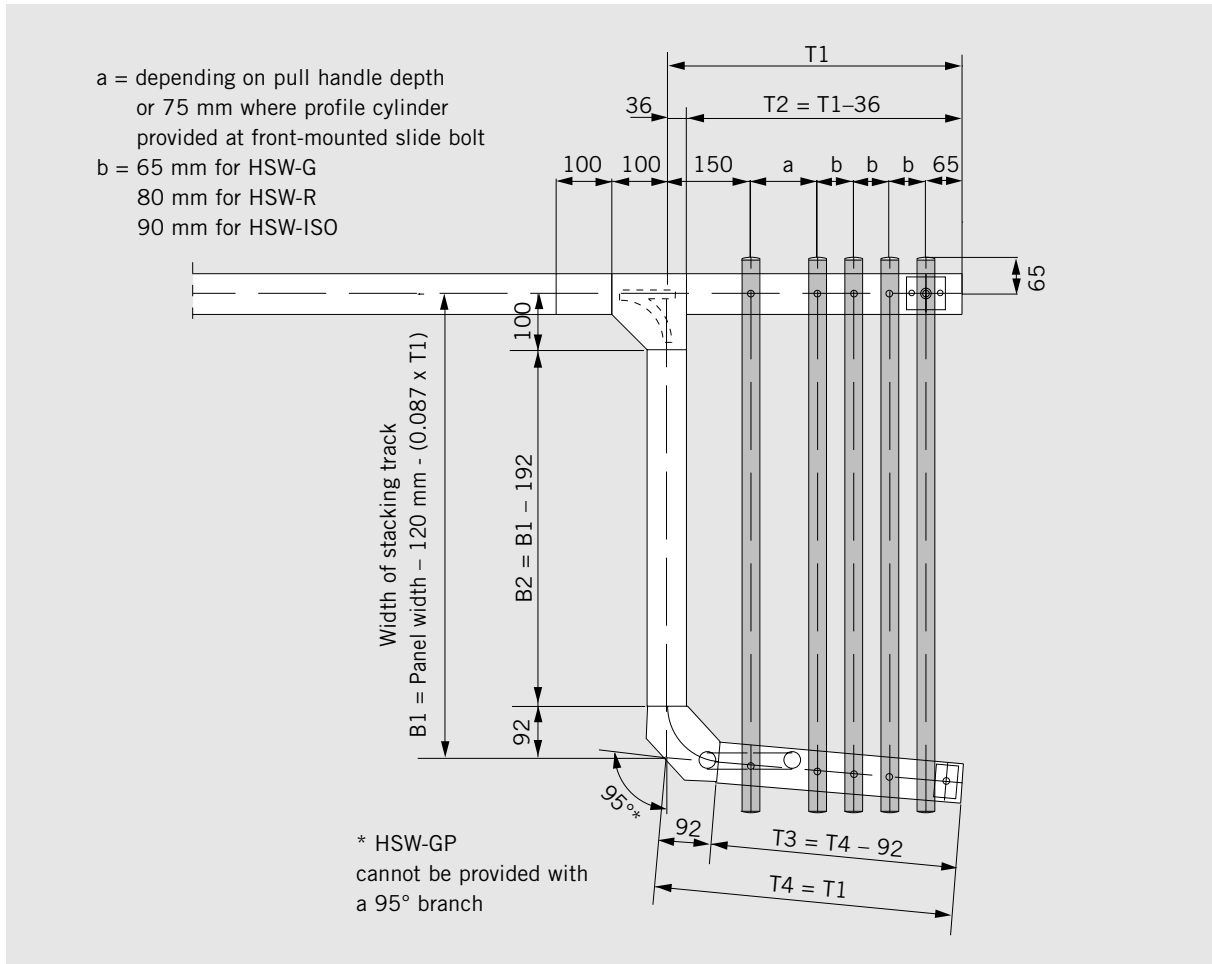

Straight track rail with stacking track parallel to direction of travel (135°)

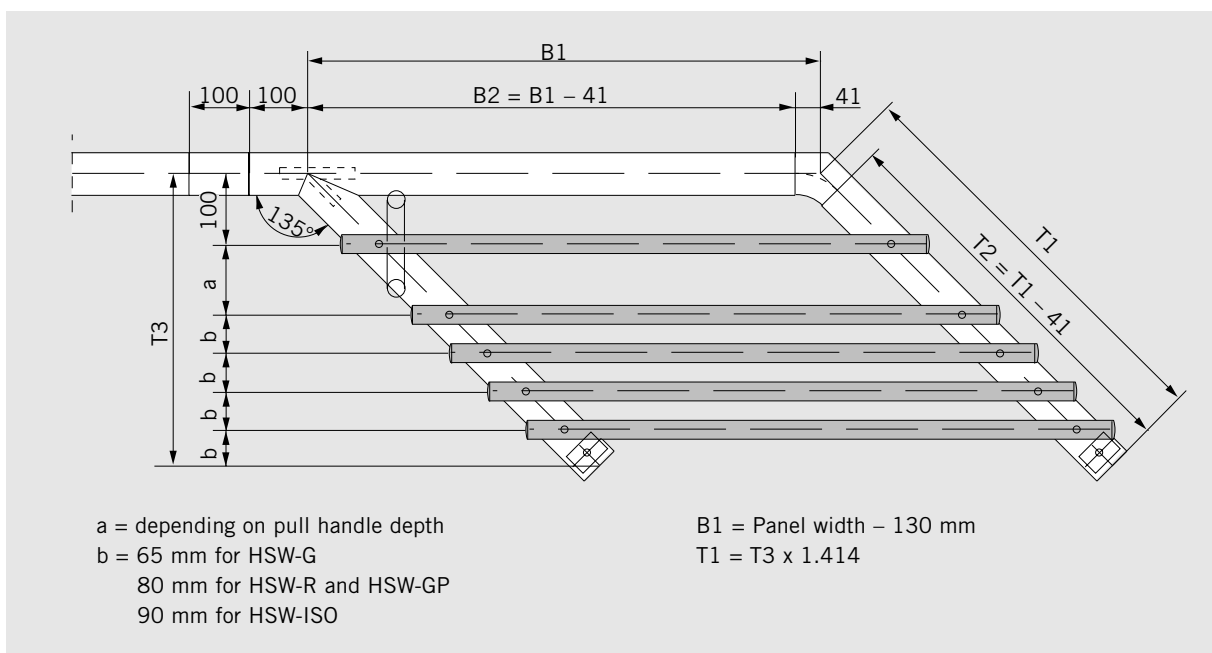

Straight track rail with stacking position parallel to travel direction (90°) with up to 6 panels

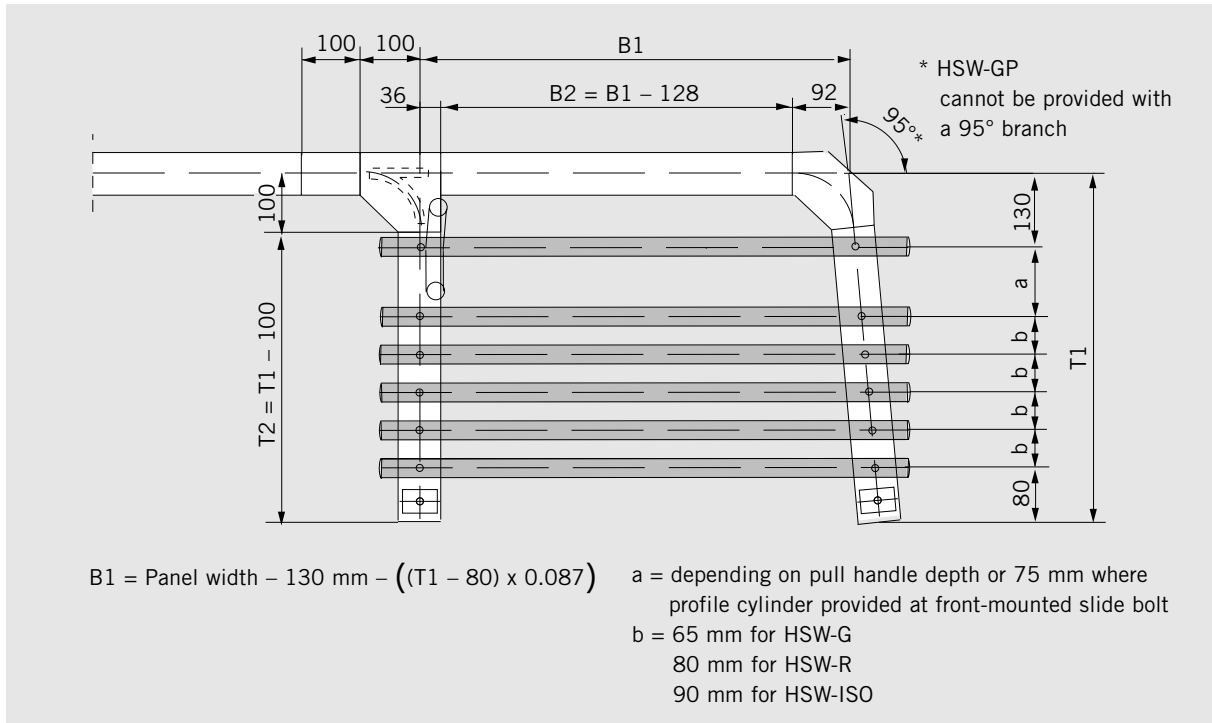

Straight track rail with stacking position parallel to travel direction (90°) with more than 6 panels

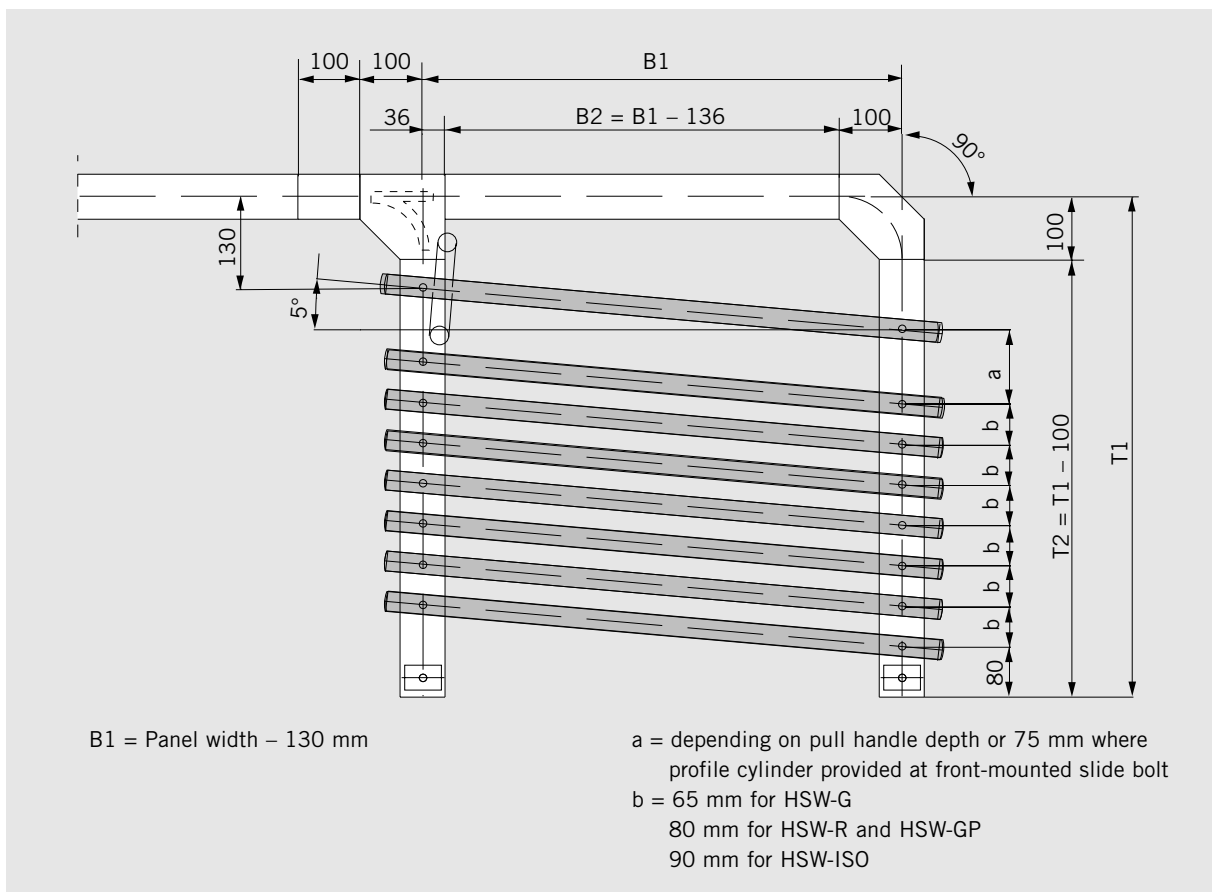

Extended application possibilities

Practical system design

DORMA-Glas offers a further stacking variant for fully glazed sliding walls, namely the niche parking system.

This has all the advantages inherent in the HSW-G design - such as individual configuration of the sliding frontage without a floor track, or incorporation of a special sliding or stationary panel as a single or double action leaf.

This version is ideal where the stacked panels of the HSW-G may constitute an obstruction or would not be in keeping with the overall appearance of the store.

The glass panels are thus parked in line within a niche comprising a double wall or a wall and other parts of the store fixtures and fittings. In this way, they do not disrupt the overall appearance of the interior.

With large systems, the panels can be stowed in parallel on two tracks instead of in a single-track line.

User-friendly

As direct access to the panels parked in the niche is not usually possible, a hand crank is used in order to move the panels back to the entry point. From here they can be pulled out manually, taken to the appropriate position and then secured with their face-mounted floor bolts.

Convenient and safe

For added convenience where the system height exceeds 3000 mm, an automatic panel removal system is recommended.

The individual panels are brought out to the niche entrance by means of a pushbutton-operated motor, enabling them then to be pulled out and positioned manually. The motor stops as soon as the pushbutton is released.



Planning

In the case of systems of angular configuration, the collision curve in the area of the angle has to be taken into account during the planning phase, and this will have varying radii depending on the panel width. The internal dimension of the parking pocket (i.e. the niche) varies depending on the system layout and panel type (see page 12). Together, the total number of panels per track should not exceed an overall weight of 1000 kg.

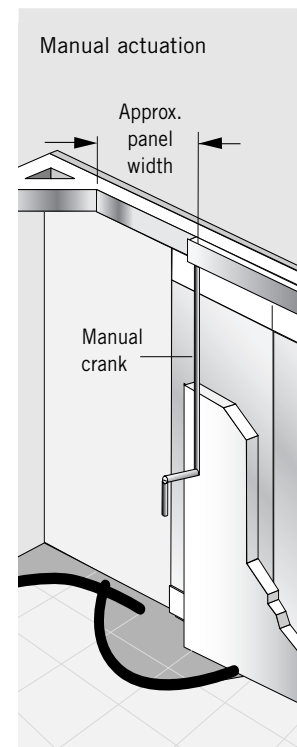
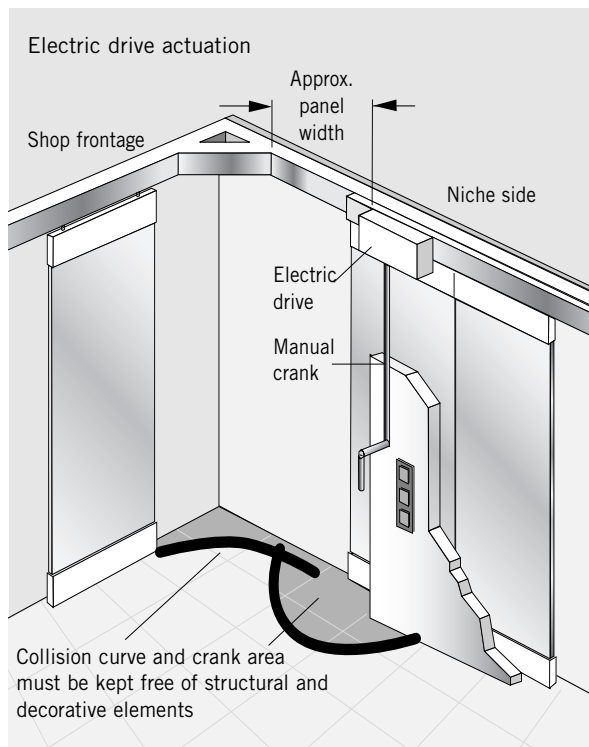

Example configurations

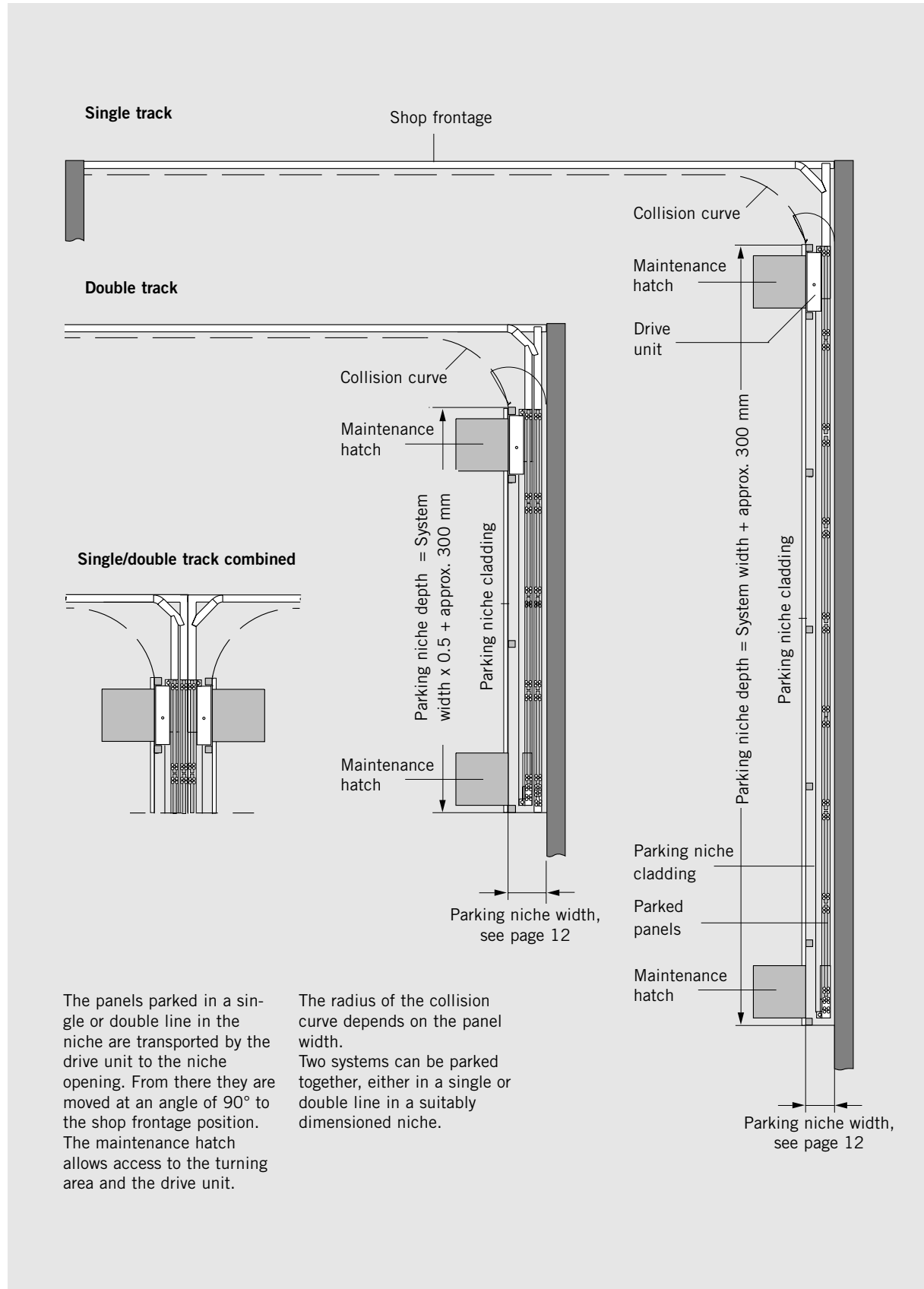

Guide values for parking niche widths (electric or manual actuation)

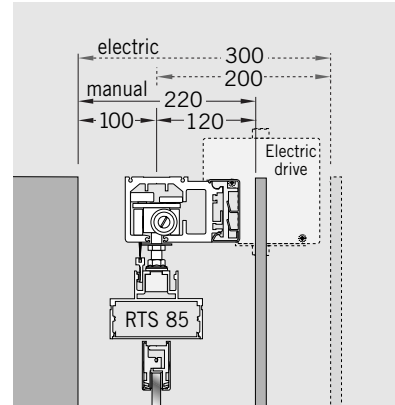
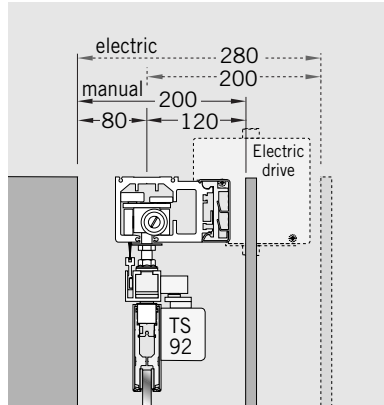
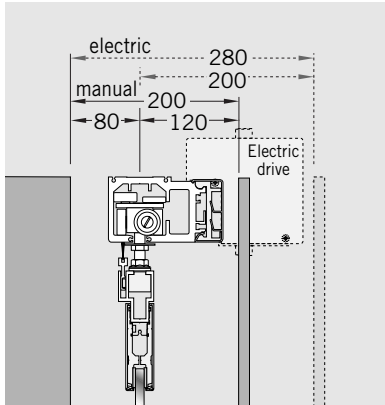

The parking niche width depends on various factors:

- Single or double-line parking
- Type of functional components (door closers, locks)
- Sequence or combination of panels located face to face

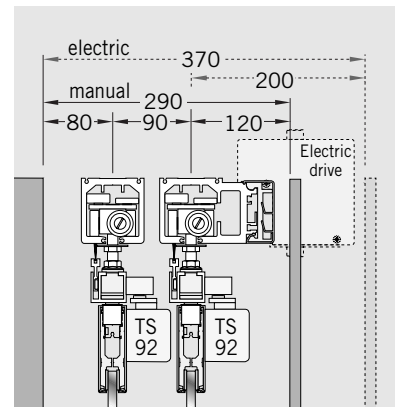
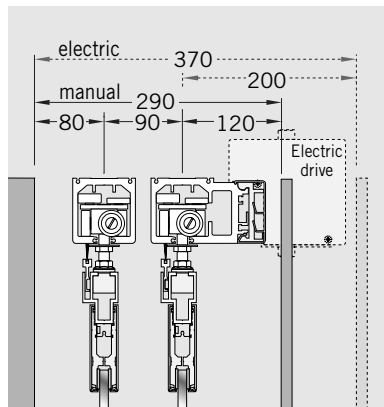

TS 92
= Door closer

RTS 85
= Transom door closer

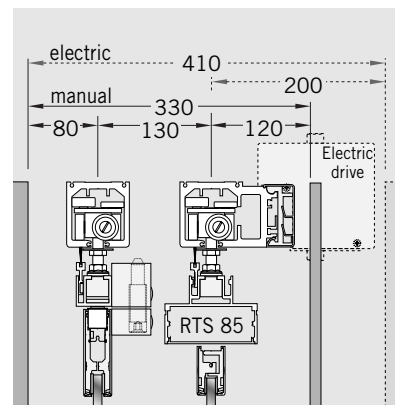
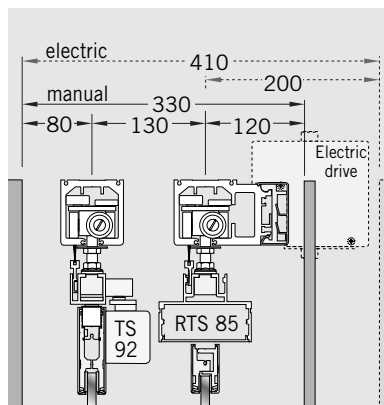
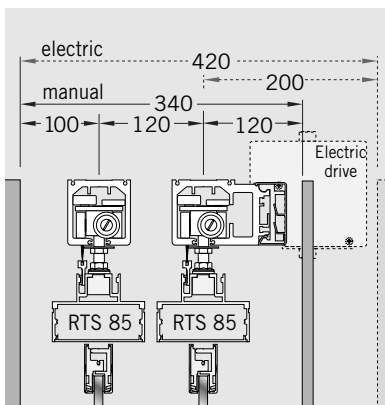
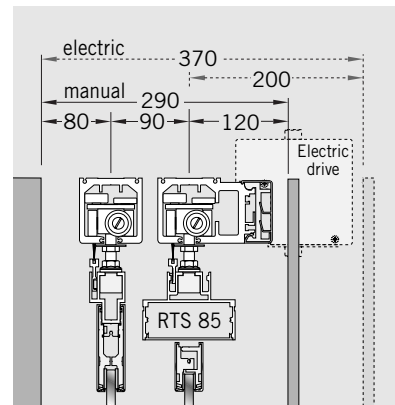
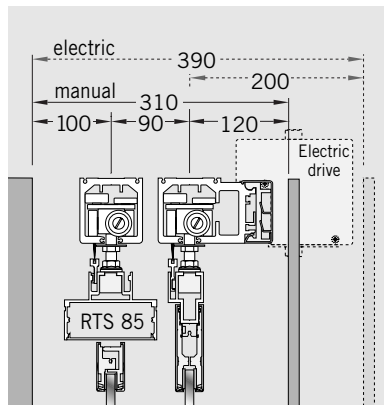

Actuation options

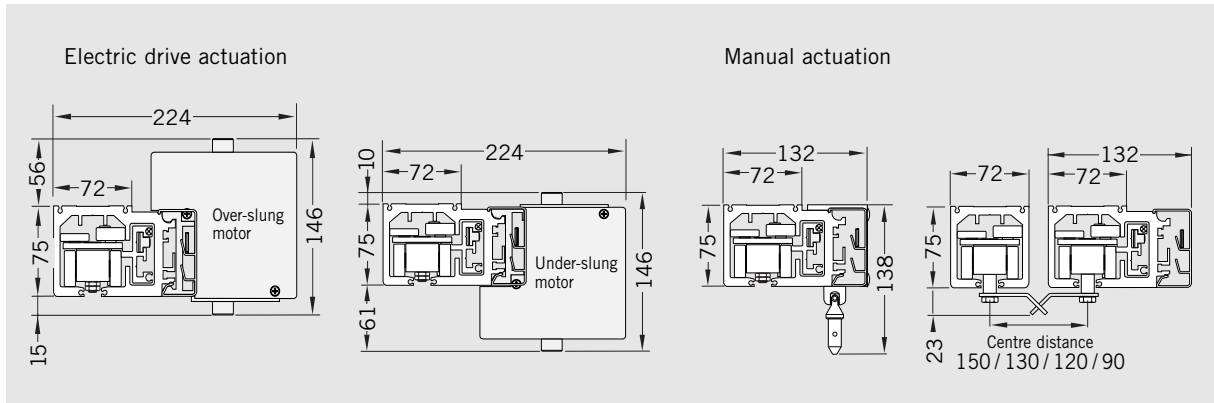

Rail arrangement

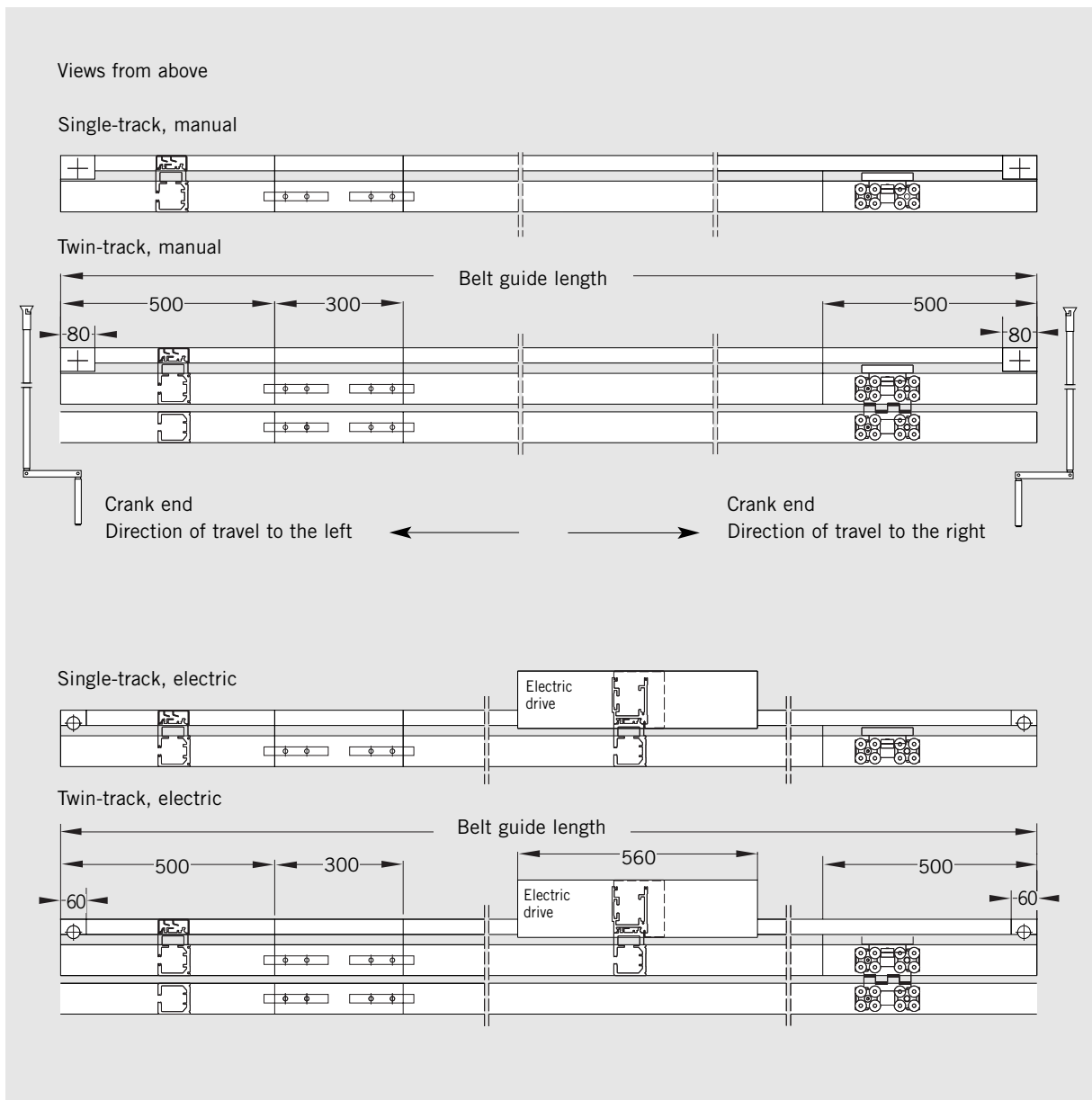

Track rails and modules

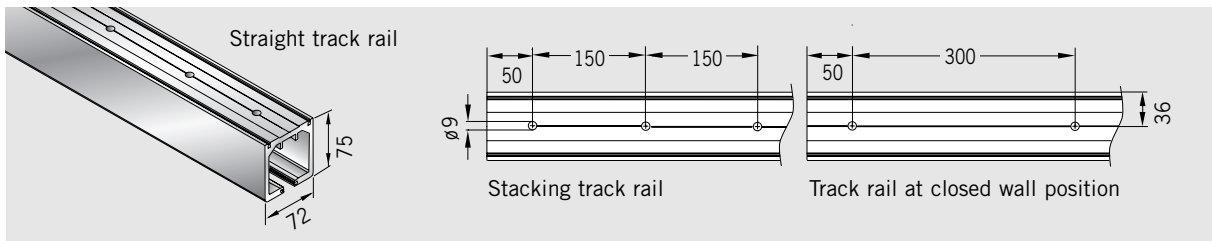

Flexible and stable

Horizontal sliding walls can be constructed in a wide range of different configurations to suit the site of installation, prevailing structural conditions and the planning concept. With DORMA HSW systems, a variety of designs can be implemented with ease. Straight, segmented and curved track rails can be combined to produce virtually any serpentine shape required. The track rails in the form of hollow sections combine all the virtues of light weight, stability and torsional stiffness. And when combined with the HSW substructure, installation becomes even easier. Flexibility and stability mean that even unusual system configurations can be implemented without problem to give maximum functional reliability.

Straight track rail

For a straight-line system configuration, a drill hole interval of 300 mm in the track rail is sufficient, while the stacking area requires an interval of 150 mm. Where the track assumes an angle of 161-179°, the track rail is mitred, while at angles between 90 and 160°, a cast curve is incorporated. The standard modules available are indicated in the adjacent illustrations.

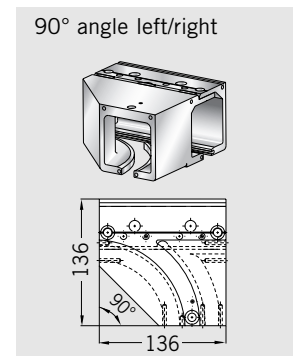
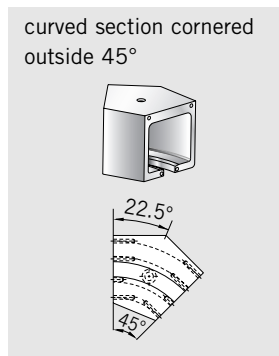
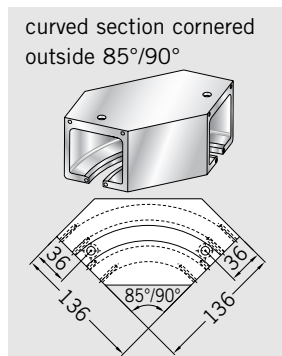
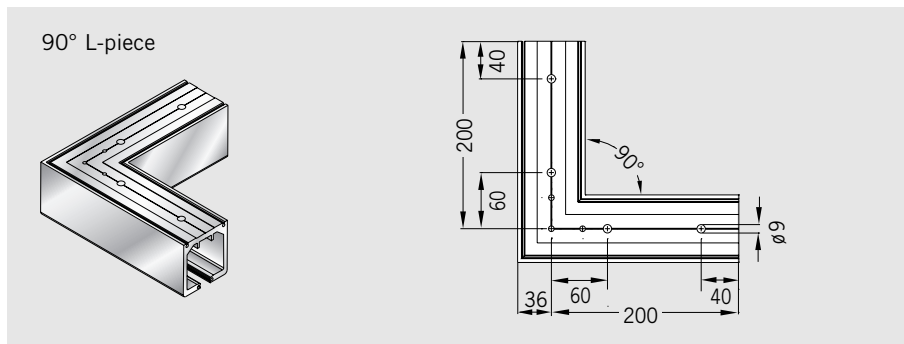
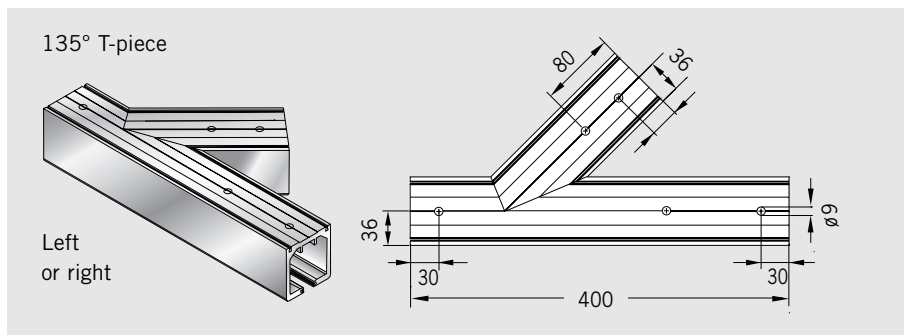
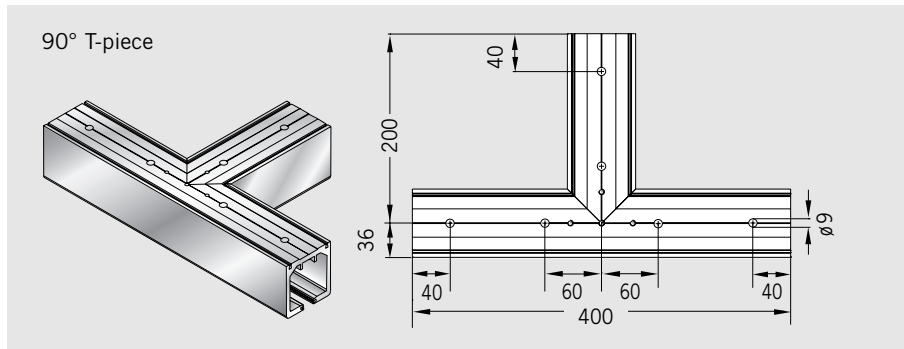

Segmented track rail

With the segmented track rail, it is possible to implement the DORMA HSW as a polygonal partition or frontage. In so doing, it is essential to note the following requirements:

- the panel width and segment chord length must be properly coordinated;
- segment panels are provided at the bottom with locks or face-mounted floor bolts and the end face profile covers are equipped with additional buffers for collision protection;
- it is important to ensure that the opening sweep of single action and double action panels does not give rise to collisions.

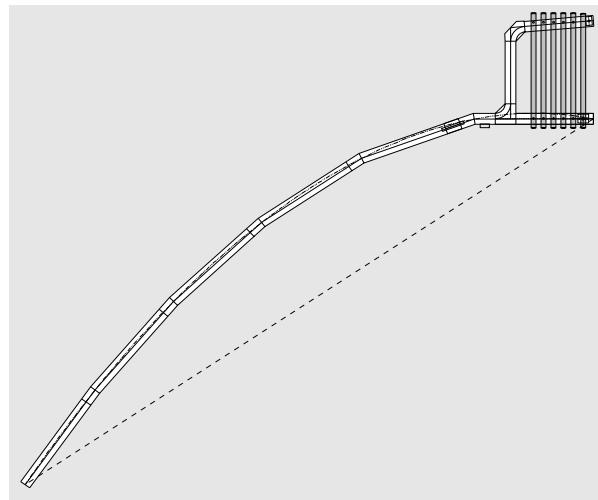

Curved track rail

A curved track rail is also available where a curved DORMA HSW system configuration is required. The most important technical prerequisites for this are as follows:

- only non-pivoting sliding panels may be installed in the curved track rail section;
- the track rail must be straight in the parking or stacking area;
- no top locking element can be installed;
- each panel is provided with two face-mounted floor bolts;
- a 100 mm straight track section ① is necessary as the transition from the curved track rail to the straight stacking track rail;
- blends from the curved configuration to a straight line can be implemented using standard modules ②;
- the smallest curve radius is 3500 mm (smaller radii on application) ③;
- the feasibility of elliptic system configurations must be considered on a case-by-case basis – for this, drawings will be necessary;
- the start and end points of the curve are always provided with a 90° saw cut (radial saw cut).

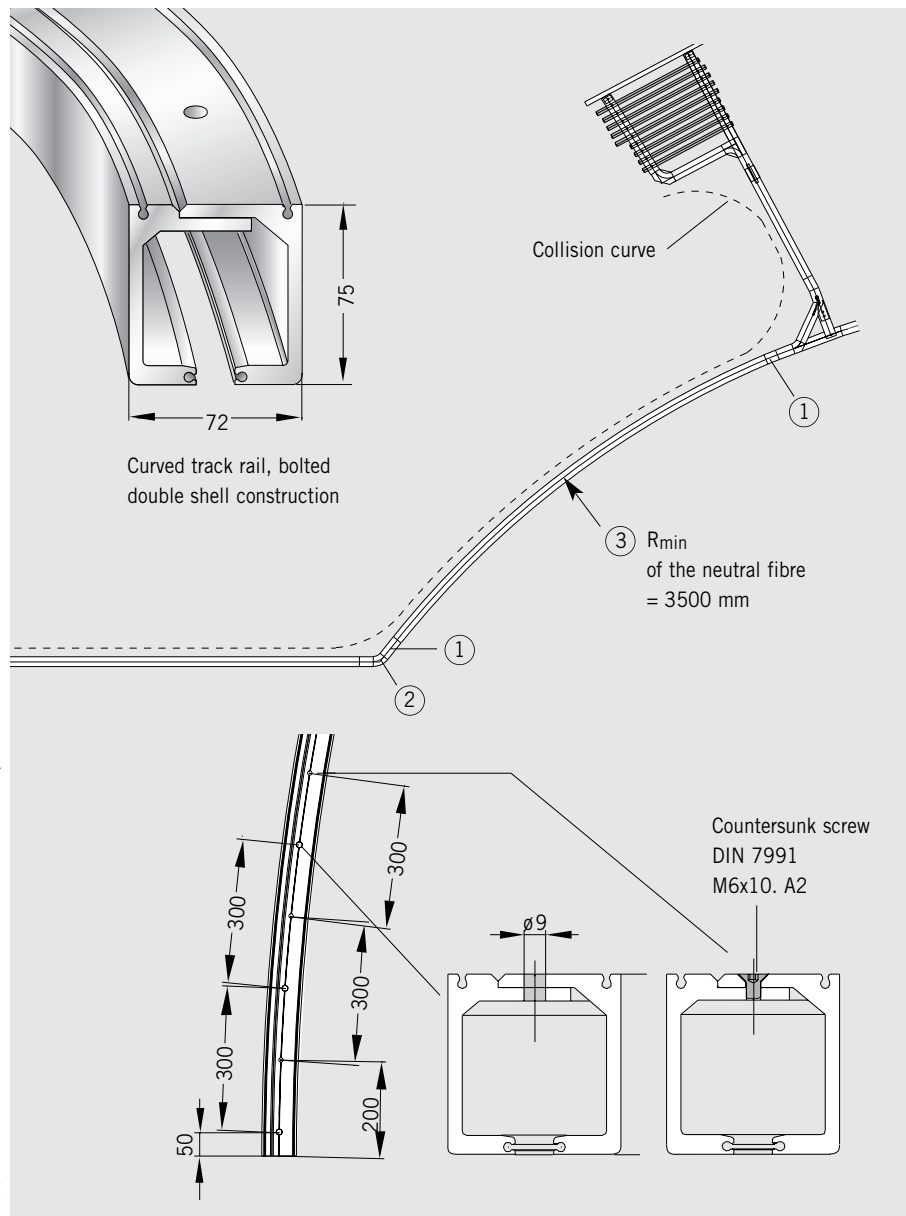

The System

Problems and solutions

Installing a horizontal sliding wall system invariably requires a certain set of structural conditions to be established. The system will need to be precisely aligned vertically - usually subsequent to installation - as well as being exactly configured and securely located. Because DORMA HSW systems do not use floor-level supports and floor tracks, the system requirements and all their technical properties must be taken into account when designing the substructure and its incorporation within the ceiling. This often very costly planning process is normally undertaken by the fabricator as the installation company, and alongside the calculations there are many individual structural and installation procedures involved. The new DORMA substructure system is of modular construction and is designed to significantly reduce on-site installation cost and time. This concept also offers the particular flexibility required to overcome structural constraints, such as the presence of air conditioning shafts or pre-existing electrical systems in the ceiling.

System design

The DORMA substructure consists primarily of the following components: substructure profile with modules for branching to the stacking area, threaded rods for suspension of the profile(s), and standard square section tubes with appropriate fixings and ceiling brackets for bracing and stiffening the construction.

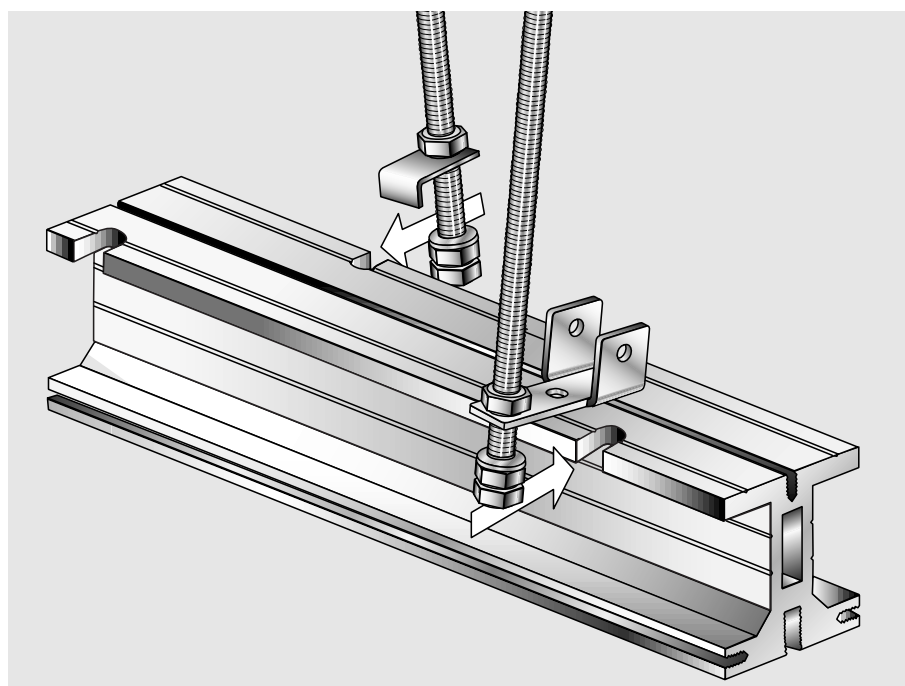
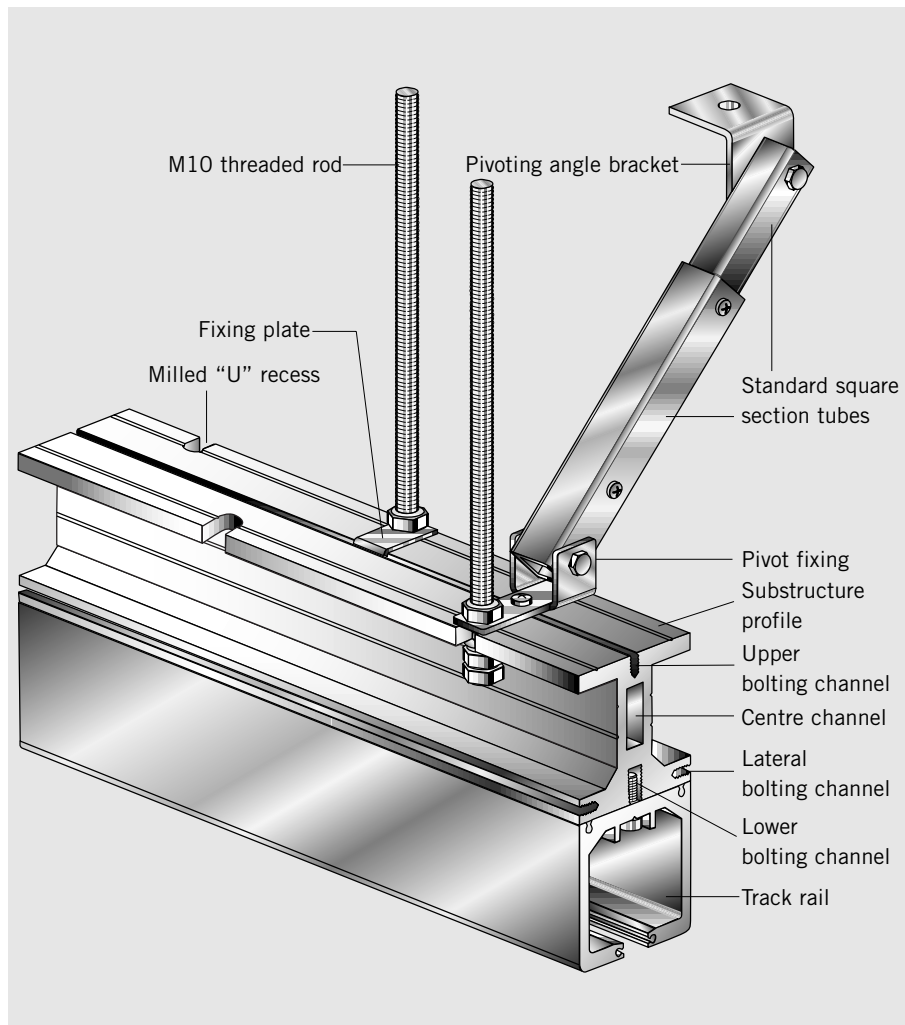

Safety and flexibility

The DORMA substructure has been developed on the basis of extensive practical experience of the requirements involved in this kind of system. Consequently, the profile incorporates features that greatly facilitate installation and ensure that pre-existing structural factors can be accommodated with maximum flexibility. Various bolting channels run the whole length of the profile, allowing bolts to be inserted easily at any location within the system configuration. So there is no need for pre-drilling and thread cutting in order to mount the track rails onto the substructure. Bolted connections can be made directly through the lower bolting channel. The problem of removing drillings and filings from the track rails is thus also a thing of the past. Bolting channels on both sides of the profile can be used e.g. for fixing the brackets needed for attaching the ceiling retention elements. In addition, centering grooves on all main profile surfaces facilitate overhead drilling, e.g. for accessory attachment. Welding brackets designed for bolting onto the profile provide another option, allowing the DORMA system to be utilised for additional customer-specific applications.

The substructure profile is suspended from threaded rods. These are first placed in the U-recesses using fixing plates that lock into the upper bolting channel. Each pair of threaded rods is regarded as constituting one suspension point. Here again the system remains exceptionally flexible: the staggered U-recesses positioned at intervals of 100 mm enhance the ability of the system to accommodate structural constraints. Depending on the weight of the system and the permitted deflection, it is possible to span a distance of up to 2.10 m between two suspension points. Standard flat steel bars can be inserted in the centre channel to further stiffen the profile, particularly in the area of the joints. This means that just one suspension point in the vicinity of the joint can be provided instead of the two - one either side of the joint - that are usually needed. So existing building installations of all types can be effectively bypassed. Once the substructure has been installed, the HSW system is vertically aligned and fixed directly via the threaded rods. Subsequent adjustments, e.g. after the building has settled into its foundations, can also be carried out by the same means.

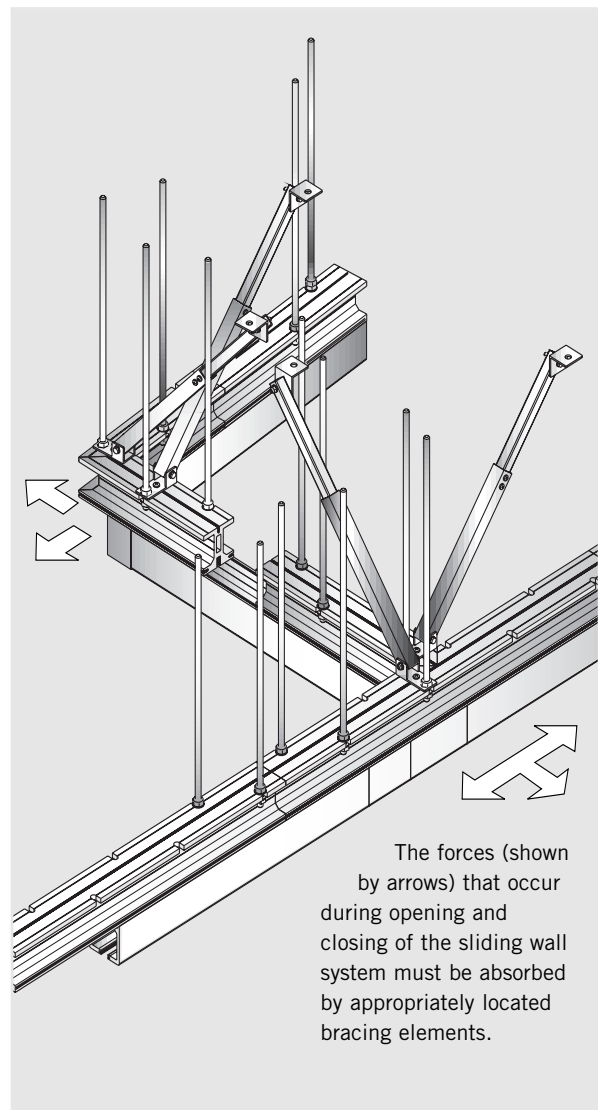

The standard square section tubes offer extra safety, especially where the sliding panels deviate from a straight line. Panel sway must be effectively countered by the structural design adopted at such locations. Diagonal struts that counteract the pressure load stabilise the system in the area of the stacked panels. The telescopic square section tubes are connected as additional bracing elements (struts) to the substructure by a pivot fixing. The struts are bolted to the ceiling using the appropriate angle brackets.

The modular design of the DORMA substructure is precisely matched to the modules of the DORMA HSW track rail. The structural elements can be mixed and matched as desired with the result that a small number of component types is sufficient to create a complex, flexible system that conforms fully to all safety requirements. A drawing of the required substructure can be requested from DORMA to supplement the HSW system drawing always supplied with the quotation.

Planning details

Max. 2 mm deflection between two suspension points

In order to prevent system sway, every second suspension point must be reinforced by a strut. The substructure profile ends (travel path and stacking area) should ideally be directly connected to the masonry or to existing structural members.

Calculating the suspension intervals

With a maximum load (panel weight) of 150 kg/m and a permitted deflection of the substructure with track rail of 2 mm, the interval between two suspension points must be no greater than 1.45 m. The table below shows other values for different loads.

Table for the calculation of the max. distance dimension

AM max.	
F	AM
60 kg/m	2050 mm
75 kg/m	1900 mm
90 kg/m	1750 mm
105 kg/m	1750 mm
120 kg/m	1600 mm
135 kg/m	1600 mm
150 kg/m	1450 mm
160 kg/m	1450 mm

F = Force
AM = Distance dimension

Force example:
The distance dimension of 108.98 kg/m = 1710 mm

Illustrative example of load values

HSW-G characteristic values

Formula for calculating the:

Glazing height

= system height - 0.309 m

= panel height - 0.193 m

Glazing weight

Glass 10 mm = 25.00 kg/m²

Glass 12 mm = 30.00 kg/m²

Door rail weight

Aluminium = 12.00 kg/m

Brass = 14.50 kg/m

Stainl. steel = 13.25 kg/m

Example system

HSW-G system in stainless steel

System height 3.50 m

Glazing thickness 12 mm

Calculation

Load

= glazing weight x glazing height + door track weight

= 30 kg/m² x (3.50 m -

0.309 m) + 13.25 kg/m

= 30 kg/m² x 3.191 m +

13.25 kg/m

= **108.98 kg/m**

Stacking area design

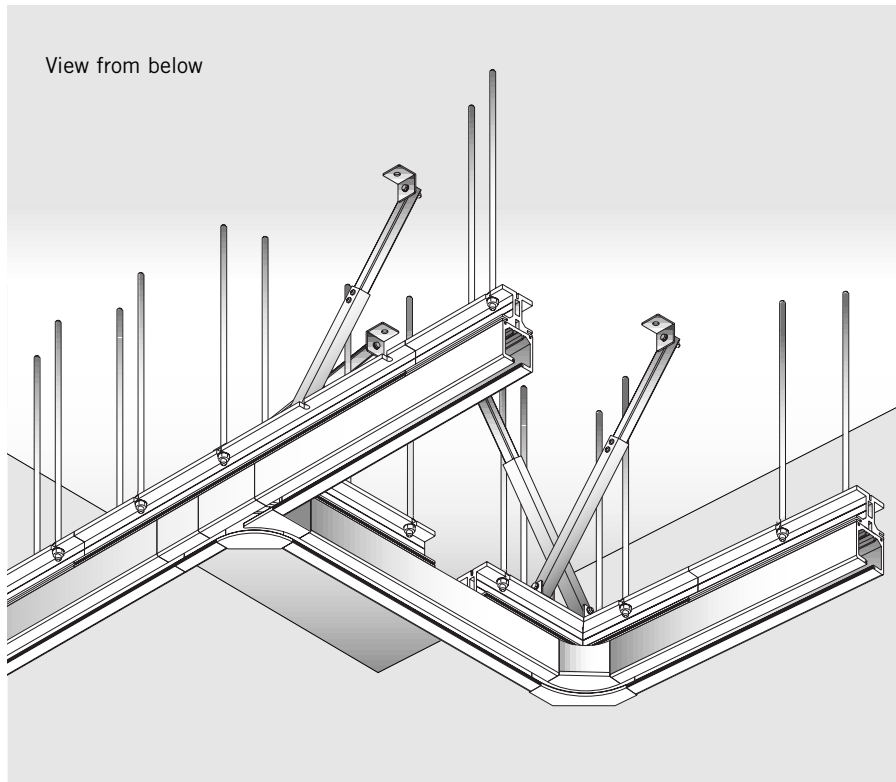

The construction of the stacking area, assembled from substructure and track rail modules, provides a good illustration of how this well-designed system can be utilised. The individual components are coordinated to ensure safe integration. Joints in the substructure are offset to those in the track rails so that individual joints coincide with continuous material in all cases.

Provided that the track rails are adequately bolted to the substructure, gaps of up to 40 cm measured from one suspension point to the next are permitted in the substructure.

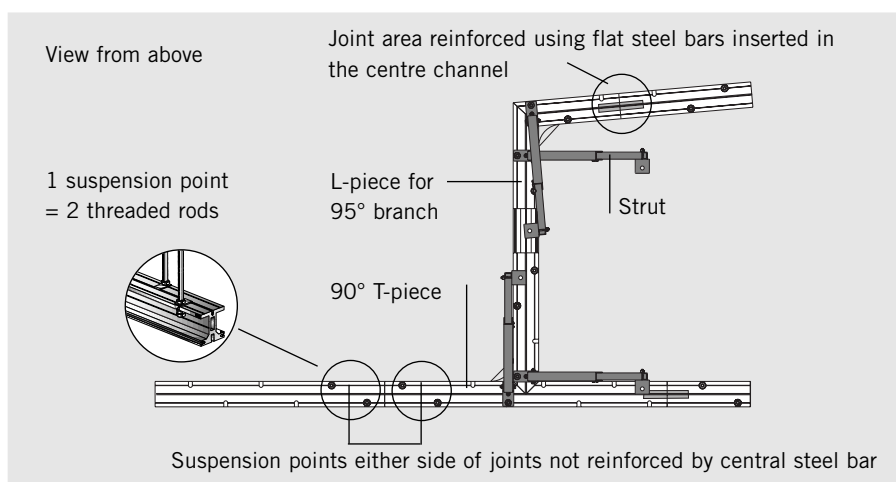
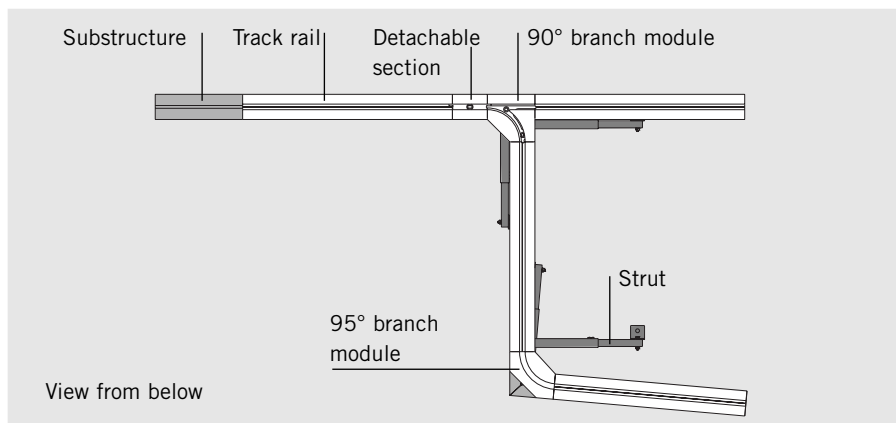

Joints reinforced by central steel bar only require one local suspension point.

Variants of connection/Details

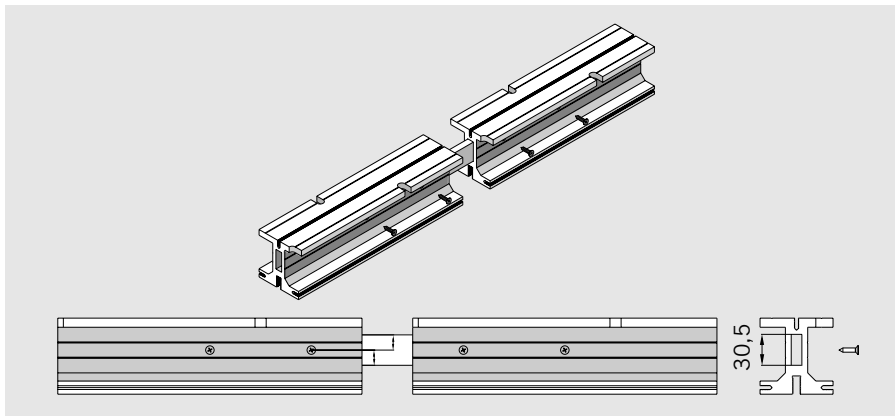

UK-Profile

Profile connection
with connection lug
Art. No. 815.442.001.40

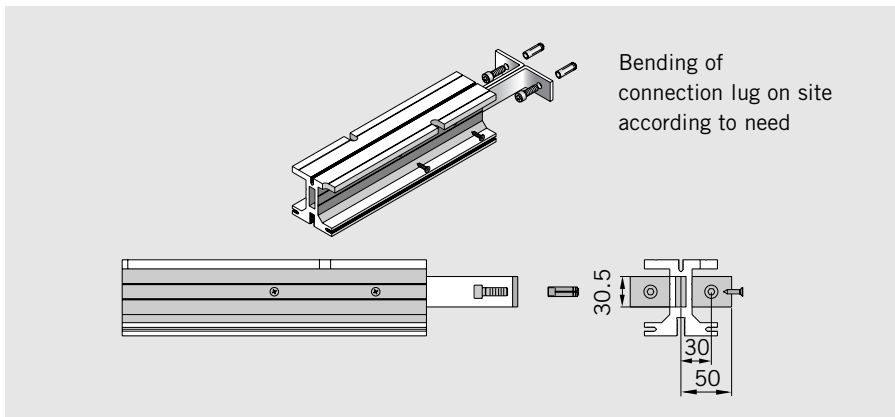

Wall connection with angled
connection lugs
Art. No. 815.442.001.40

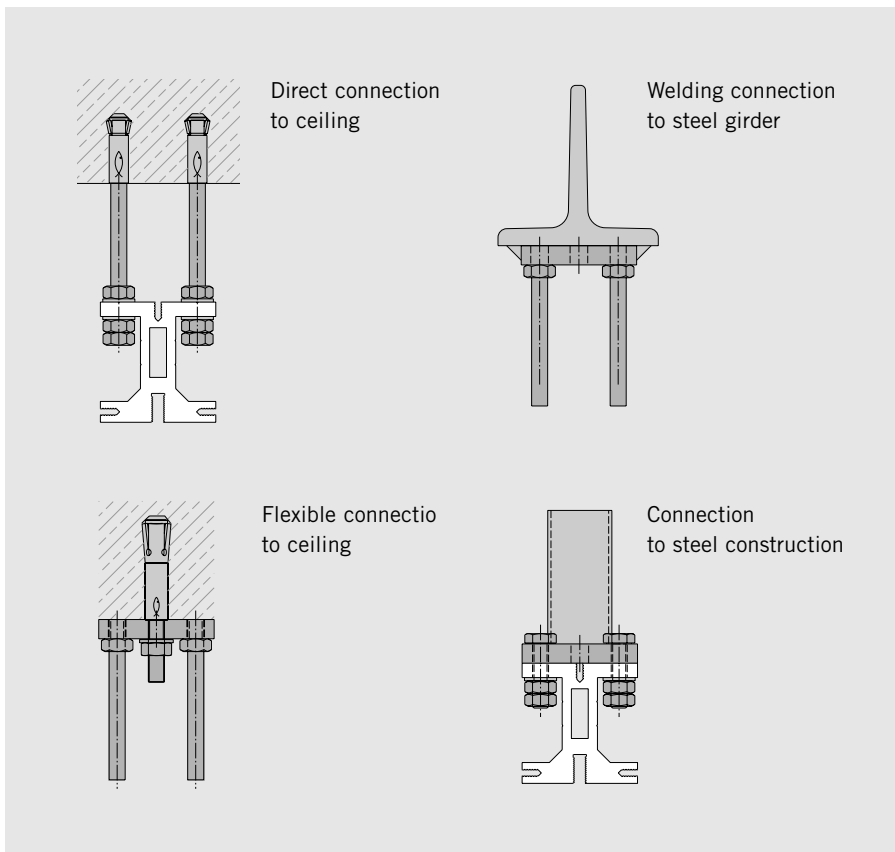

Connection opportunities
to existing bearing structure
like ceilings, balks, steel
girder by dint of adapter plate
Art. No. 815.435.001.40

Component parts, accessories

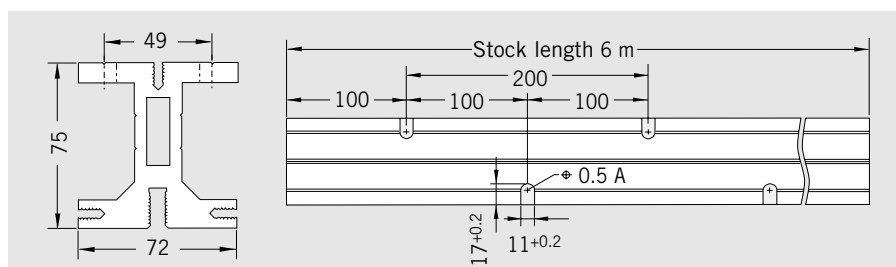
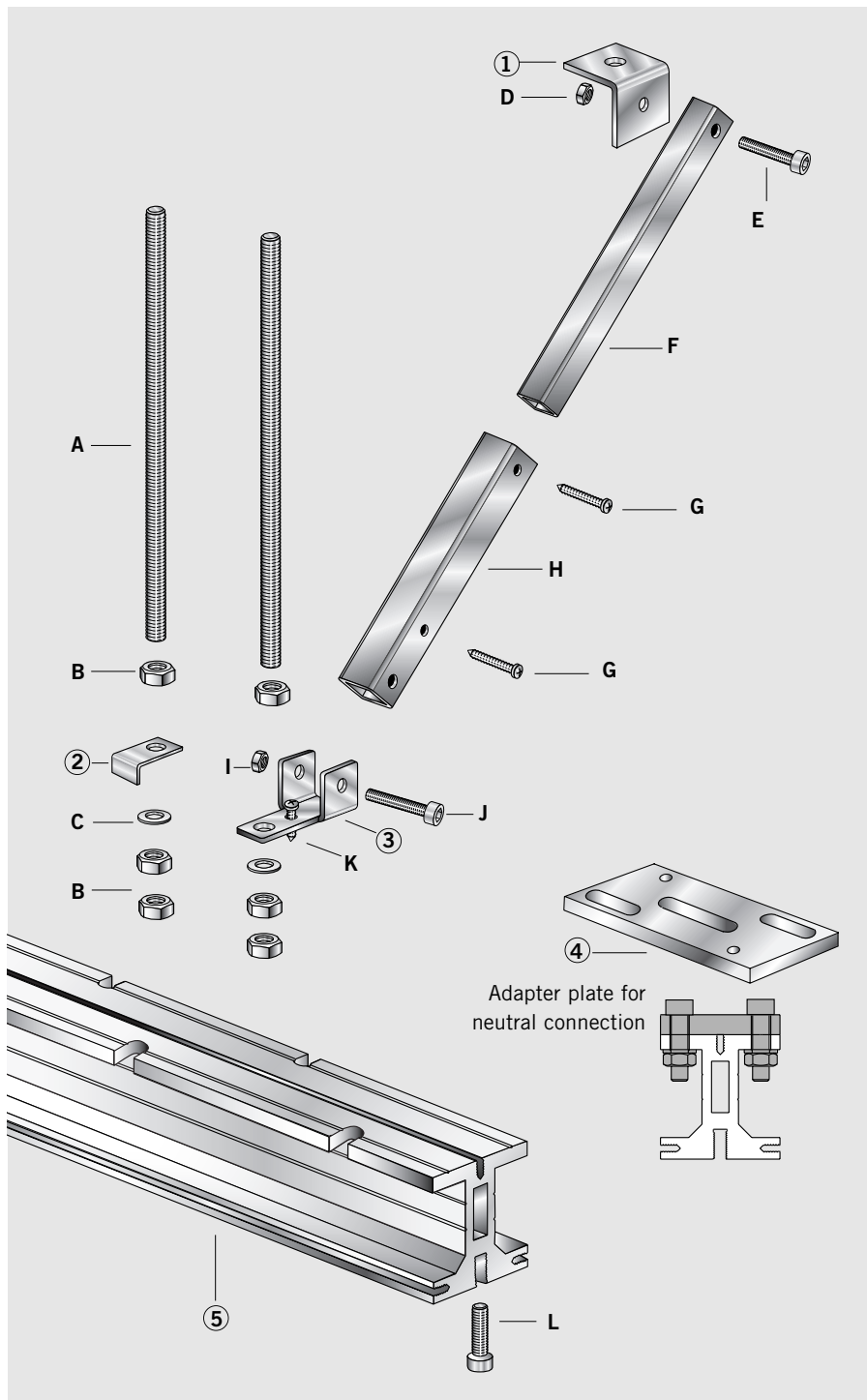

Component parts

- 1** Pivoting angle bracket
Art. No. 815.437.001.40
- 2** Fixing plate
Art. No. 815.434.001.40
- 3** Pivot fixing
Art. No. 815.436.001.40
- 4** Adapter plate
Art. No. 815.435.001.40
- 5** Basic substructure profile,
stock length 6 m
Art. No. 815.658.000.99
Fixed length
Art. No. 815.659.000.99

DIN and standard parts by others or on request
CSN = Company standard no.

A Threaded rod M10 x 1000
CSN 800.01.470.3.30

B Hex nut DIN 439-2 M10
CSN 800.03.001.3.30

C Washer ISO 7089-10
CSN 800.04.009.3.30

D Hex nut DIN 934-M6
CSN 800.03.005.3.30

E Hex socket screw
DIN 933-M6x35
CSN 800.01.337.3.30

F Telescopic strut top section,
square section tube,
galvanised steel 20x20x2
CSN 800.16.025.4.32

G Drilling screw DIN 7504
ST4 8x16
CSN 800.01.286.3.30

H Telescopic strut bottom
section, square section tube,
galvanised steel 25x25x2
CSN 800.16.026.4.32

I Hex nut DIN 934-M6
CSN 800.03.005.3.30

J Hex socket screw
DIN 933-M6x40
CSN 800.01.319.3.30

K Self-tapping screw
ISO 7049-St4.8 x 13-C-H
CSN 800.01.493.3.30

L Cheesehead screw
for fixing track rail to
substructure profile
DIN 912-M8x25
CSN 800.01.018.3.30

Panel types

In the case of the fully glazed HSW-G system, the panels create a continuous, transparent surface without any lateral framing.

For a more sophisticated or intricate appearance, single-point fixings (HSW-GP) are also available.



Example of an HSW-G system
Fully glazed with door rails

This folding system with top and bottom glazing rails coordinates perfectly with the HSW-G variant. The FSW-G operates without a separate stacking area, and instead folds together within the main frontage or partition zone.



Example of an FSW-G system
Hinge-linked door rails

**HSW-G /
FSW-G,C,C plus**
Fully glazed with door rails

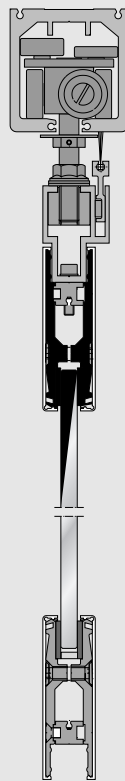

HSW-G / FSW-G
FSW-C/C plus

HSW-GP
Fully glazed
with single-point
fixings

HSW-GE BOXes
Fully glazed
with
patch fittings

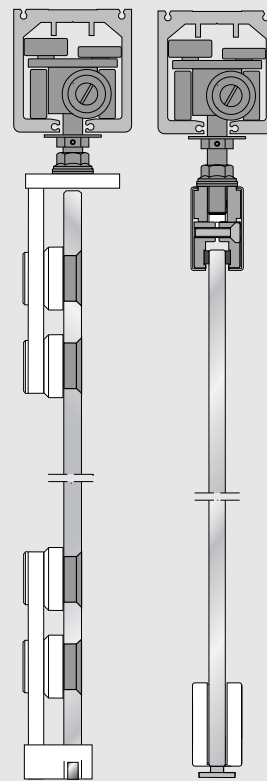
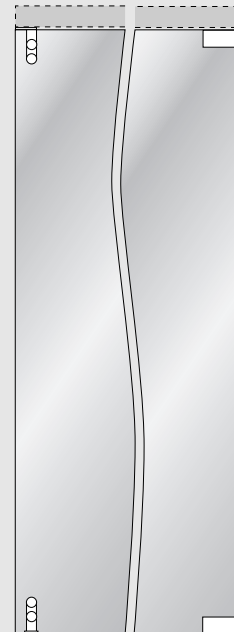

HSW-GP

HSW-GE BOXes

HSW-R
Fully
framed

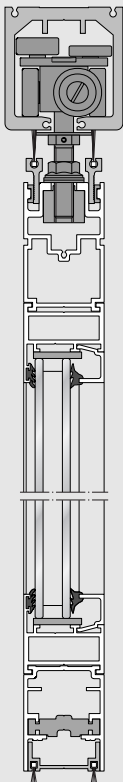

HSW-ISO
Fully framed
with double glazing

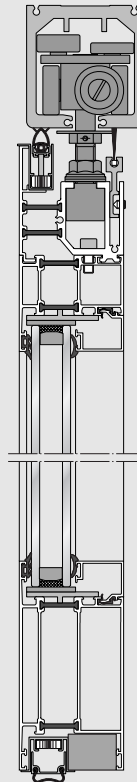

The all-round framing provided on the individual panels of an HSW-R system not only offers high stability but also an excellent barrier to keep out external influences. The panels can be constructed with laminated or toughened safety glass as required.



Example of an HSW-R system
Fully framed
or HSW-ISO
Fully framed with thermal-break frame profiles

HSW-G panel types and functions

Horizontal sliding walls
Fully glazed with glazing rails
top and bottom



Within an HSW-G system, the individual panels can be designed to perform certain special functions. These range from simple sliding panels to integrated doors with a variety of door closers, or special panels for unusual installation situations. And each system can be assembled to suit individual requirements.

Max. panel sizes and weights

Max. system height	4000 mm	4000 mm	3600 mm	3000 mm	3600 mm
Max. panel width	1250 mm	1250 mm	1250 mm	950 mm	1250 mm
Max. panel weight	150 kg	150 kg	100 kg	75 kg	100 kg

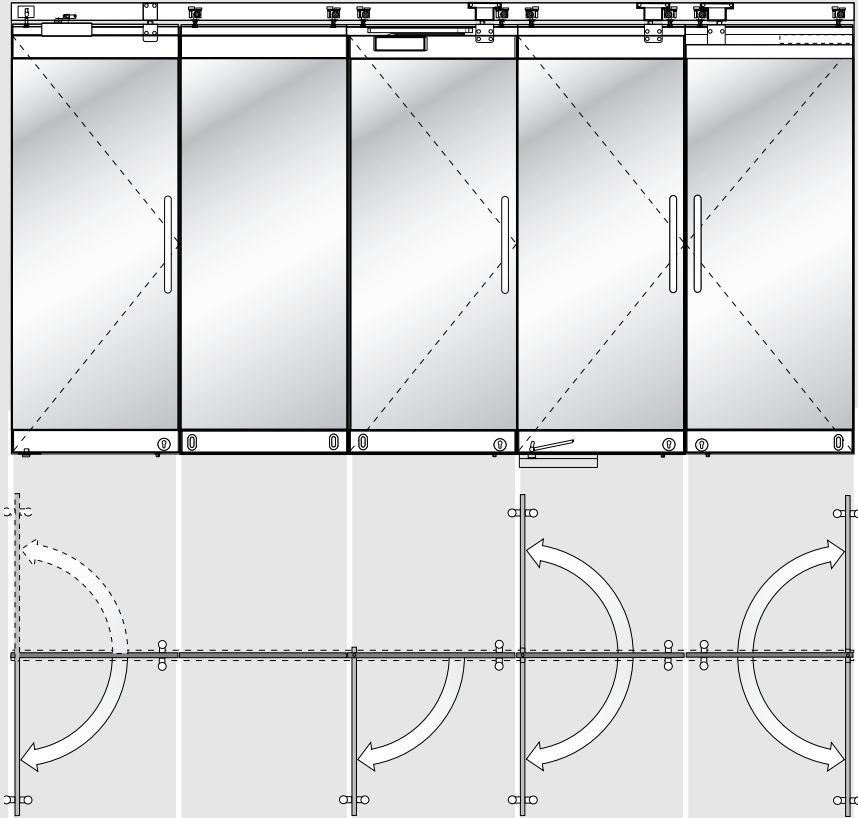

Single action/double action end panel
Non-sliding.
Single action panel with floor pivot and TS 73 door closer.
Double action panel with floor pivot or BTS floor spring.

Sliding panel
Fixed when frontage closed.

Single action sliding panel
Single action sliding panel with TS 92 cam-action door closer, operational when frontage closed.

Double action sliding panel *
Double action sliding panel with BTS floor spring, operational when frontage closed.

Double action sliding panel *
With RTS transom door closer, operational when frontage closed.

The individual panels can also be of differing widths.
The largest width should not exceed max. 115% of the smallest width.

* For these panel types please consider our notes on portal systems on page 89.

HSW-G system design

Irrespective of the function of the individual panels, an HSW-G system comprises the following basic components:

- 1 Installation-efficient DORMA substructure to accommodate track rail mounting requirements (optional)
- 2 Track rail for bolting to the substructure.
- 3 Carrier
- 4 Suspension assembly and bearing profile for safe and easy sliding of the panels.
- 5 Top door rail and bottom door rail, both comprising base profiles with clip-on face and side covers.
- 6 Toughened safety glass or toughened laminated safety glass (by others)
- 7
- 8

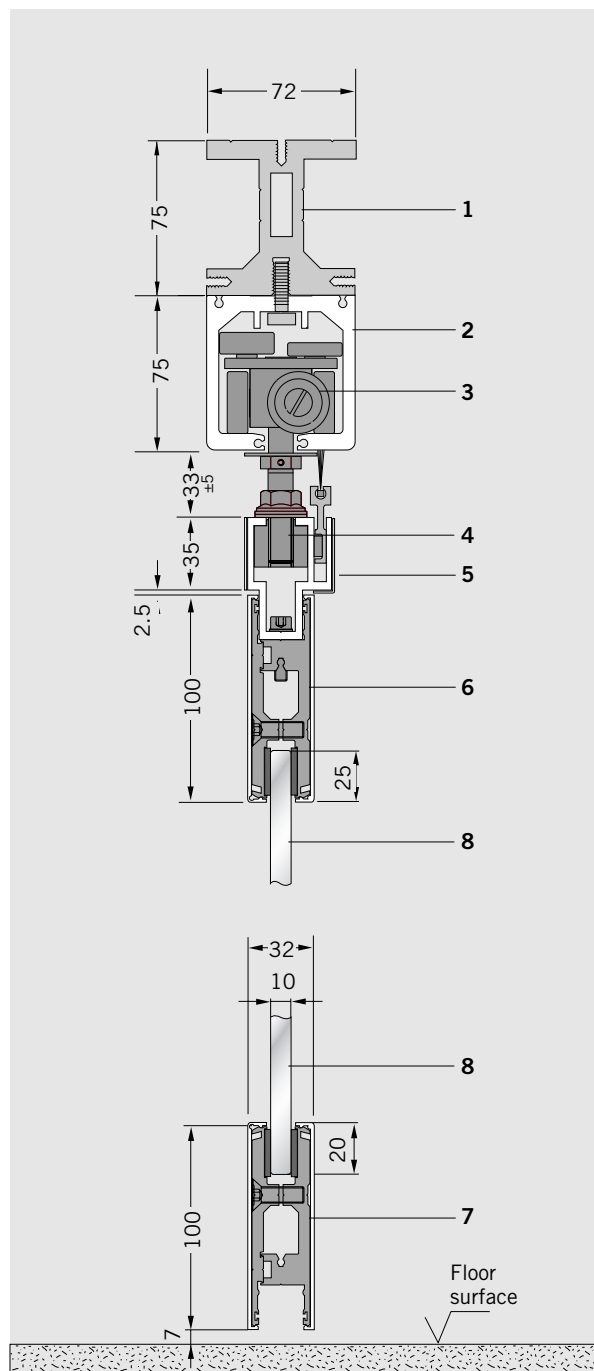

Bottom door rail designs

All depicted combinations are also available as mirror arrangements

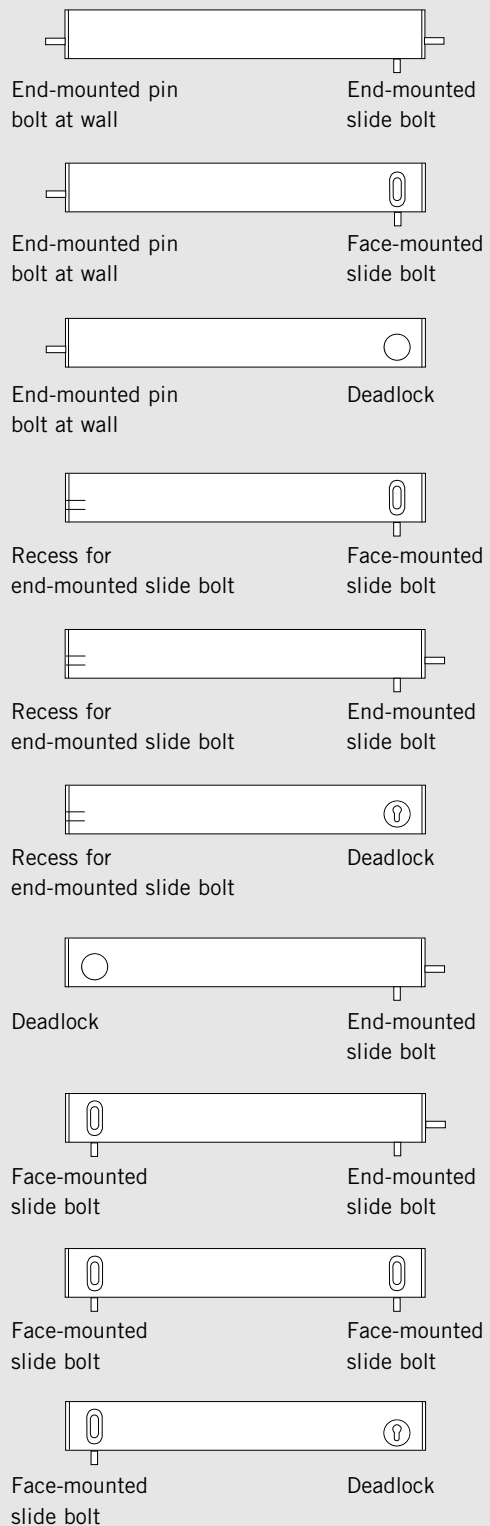

End panel

Non-moving and always equipped with a bottom deadbolt with the option of a top bolt or side-action dead-lock.

Can be designed as a double action or single action leaf.

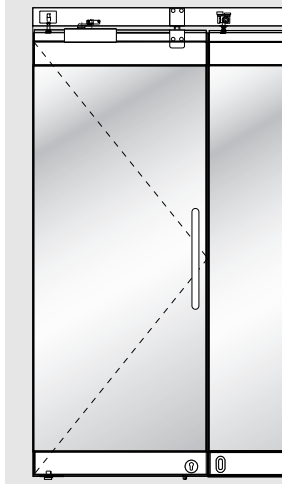

Double action end panel

Assembly types:

- Floor pivot with round spindle
- BTS 84 for panels up to 100 kg, with optional hold-open at 90° door opening angle
- BTS 80 for panels up to 150 kg with adjustable hold-open device

Single action end panel

with stop-type covers top and bottom.

Assembly types:

- Floor pivot with round spindle
- As above, but with DORMA TS 73 or TS 92 overhead door closer
- BTS 84 for panels up to 100 kg, with optional hold-open at 90° door opening angle
- BTS 80 for panels up to 150 kg with adjustable hold-open device

Single action or double action end panel with floor pivot

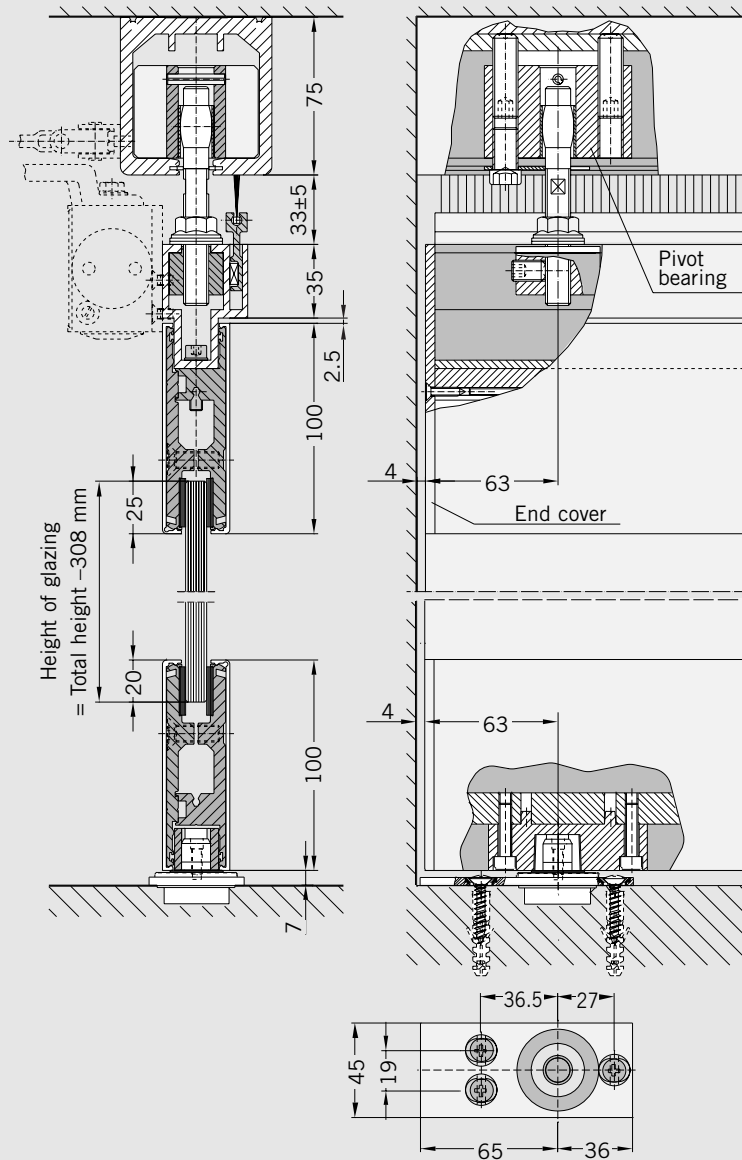

Double action end panel with floor spring

Mounting dimensions

	BTS 84	BTS 80
a	108	78
b	40	60
c	306	341
d	51-58	51-57

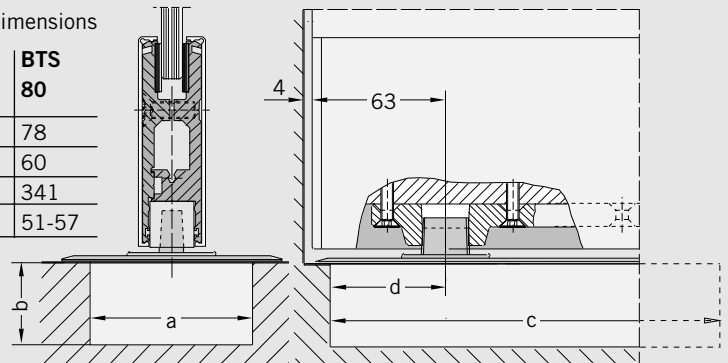

Single action end panel with TS 73 overhead door closer and additional locking device

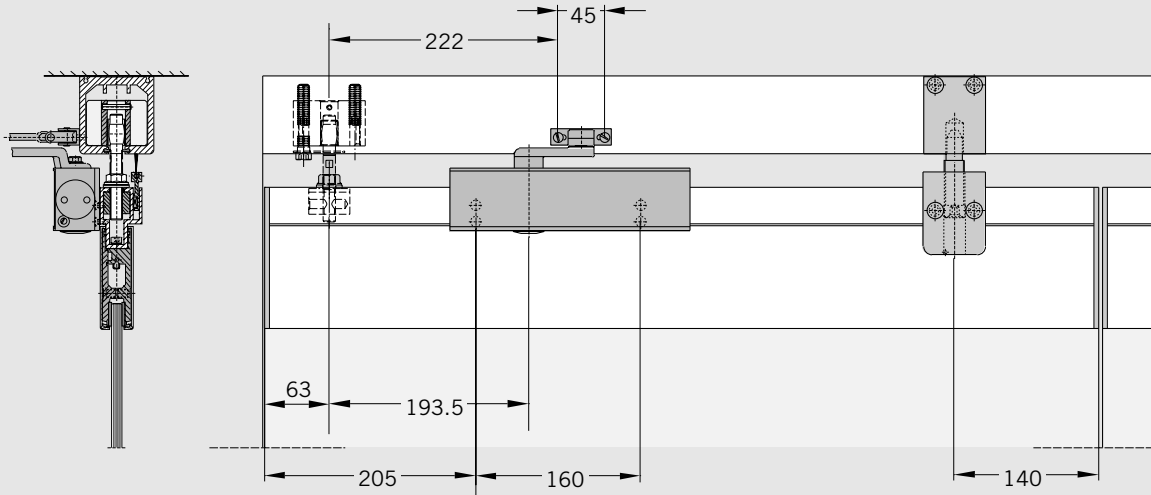

Single action end panel with TS 92 overhead door closer and additional locking device

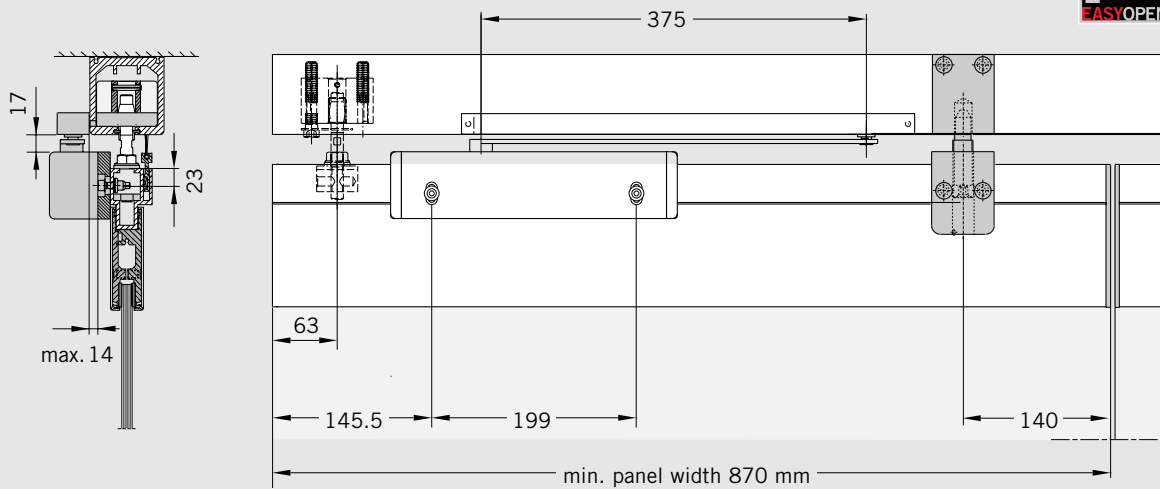

Additional locking device

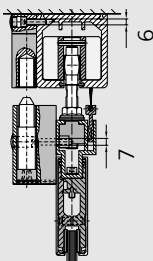

Data and features	TS 73 V	TS 92
Closing strength, variable	Size EN 2-4	Size EN 2-4
Non-handed	•	•
Closing strength continuously adjustable	via adjusting screw and arm hinge	via adjusting screw
Closing speed variable by valve adjustment	•	•
Latching speed adjustment	via arm	via valve
Cushioned stay limit, mechanical	•	•
Weight	1.8 kg	1.9 kg
Length	233 mm	281 mm
Overall depth	42.50 mm	47 mm
Height	60 mm	65 mm

Sliding panel

Stationary when the frontage or partition is closed.

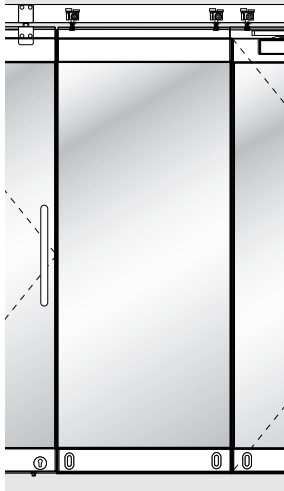

Sliding panel

The sliding panels are the moving elements. Once in their closed position, they are locked down. The components available for this are provided in the bottom door rail in the form of face-mounted slide bolts, end-mounted slide bolts, end pin bolts or deadlocks.

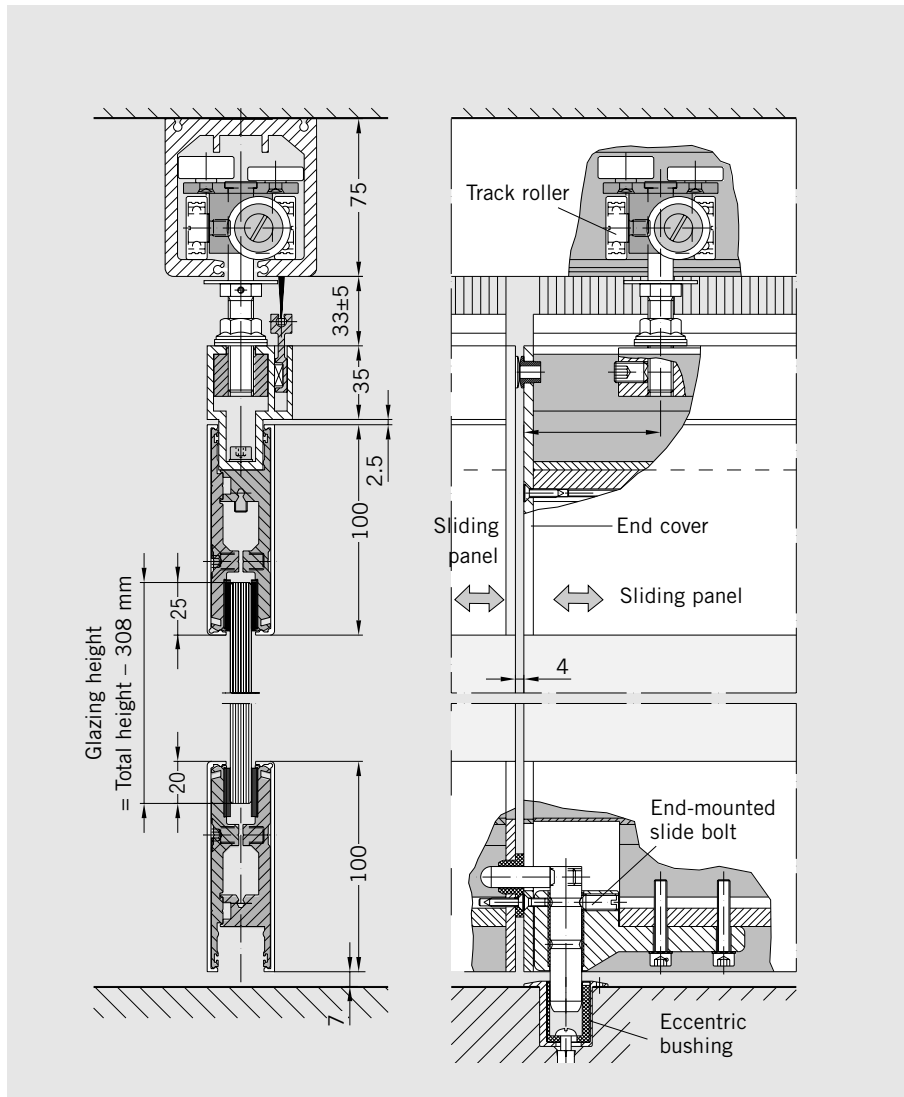

Bottom door rail

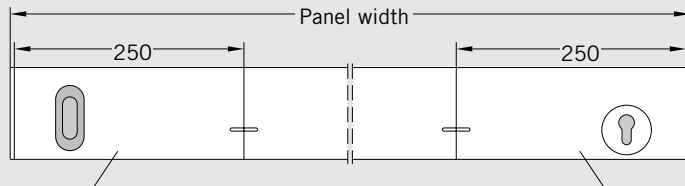

Base profile with integral functional element (here: face-mounted slide bolt)

Base profile with functional element (here: deadlock)

Single action sliding panel

Swing panel with TS 92 cam-action door closer for operation as a single action door when the frontage is closed.

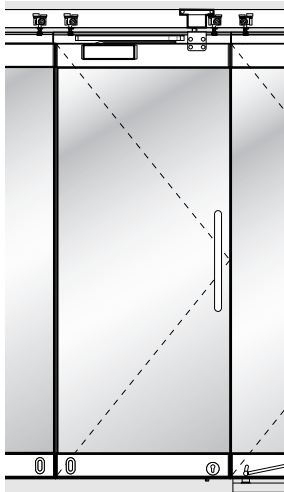

Single-action sliding panel with DORMA TS 92 cam-action door closer

This panel type is installed where doors only need to be opened in one direction. The pivoting sliding panels can be fitted open inwardly or outwardly. In both cases, the cam-action door closer is fixed to the inside face.

Standard assembly

- top: Pivot bearing, TS 92 with slide channel, one locking device
- bottom: Face-mounted slide bolt as pivot (released for sliding function) and lock

Optional equipment

- top: Second locking device (for reshuffle bypass)
- bottom: Optional second face-mounted slide bolt instead of deadlock

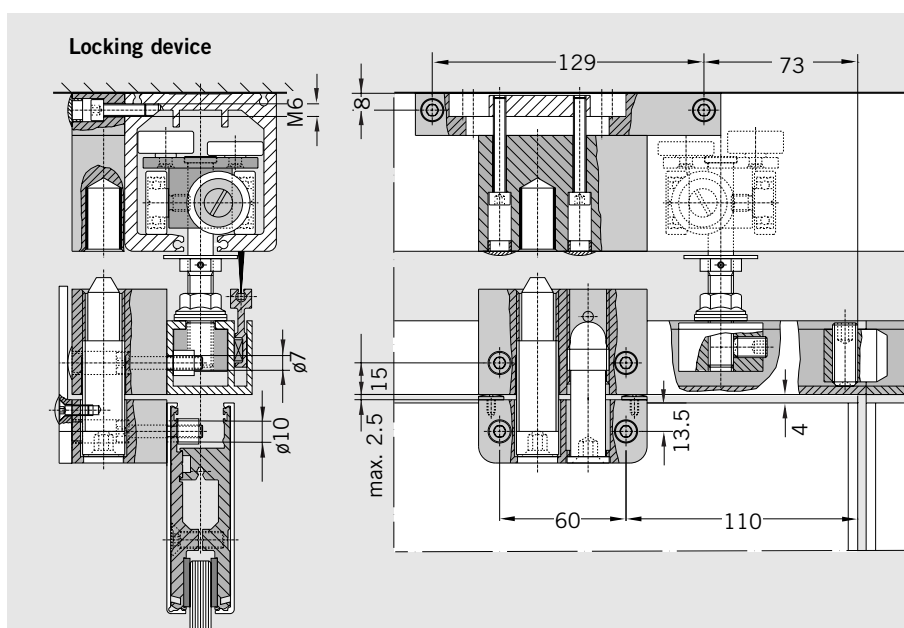
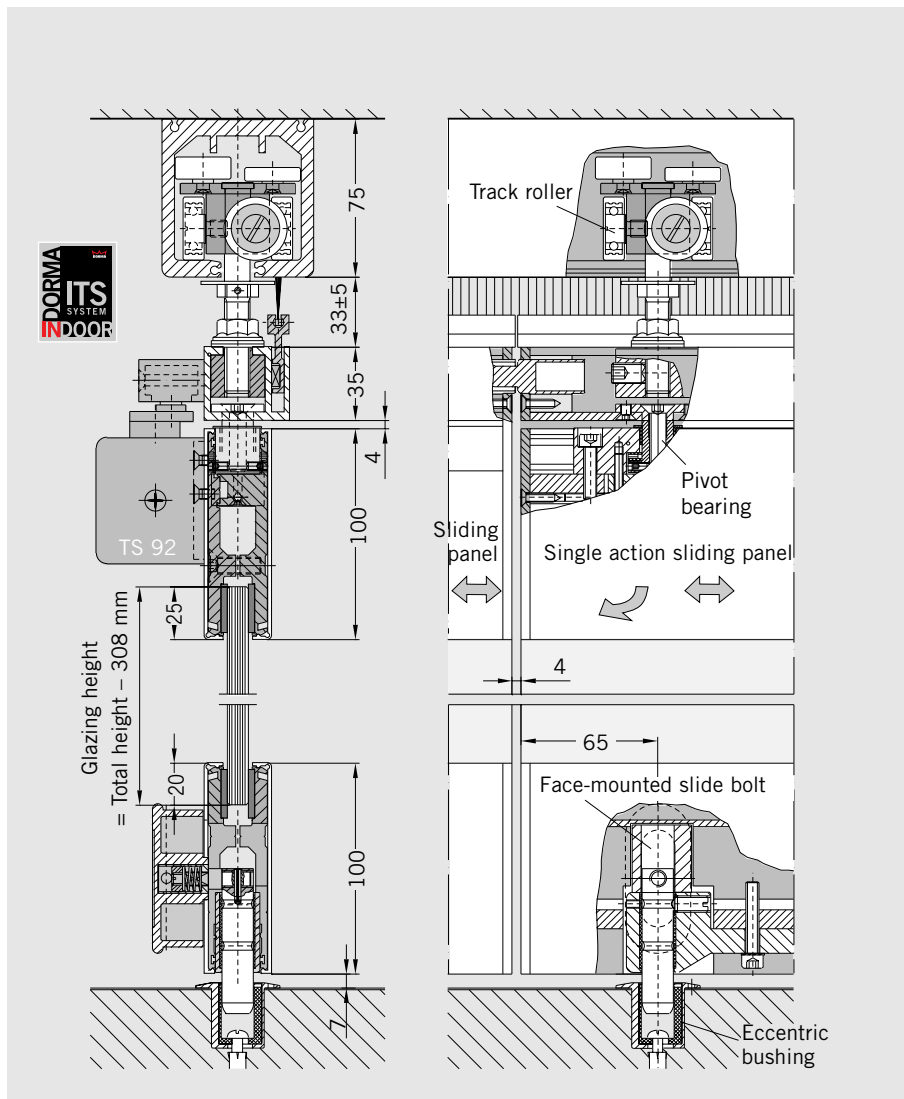
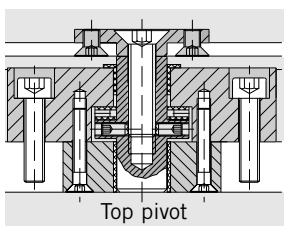

Double action sliding panel

Pivoting panel with BTS floor spring for operation as a double action door when the frontage is closed.

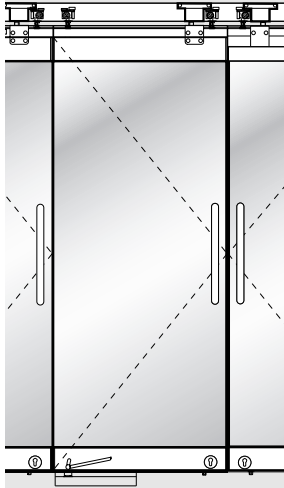

Double action sliding panel with DORMA BTS floor spring

The combination of double action sliding panels with DORMA BTS floor springs has become a classic solution. These panels are generally equipped with a bottom dead-lock and top locking device.

Assembly types:

- BTS 84'Z' for double action sliding panels with BTS at 80 kg, with optional hold-open at 90° door opening angle.
- BTS 80'Z' for panels up to 150 kg with adjustable hold-open device.

The maximum weight for the double action sliding panel with DORMA BTS floor spring is 75 kg.

For these panel types please consider our notes on portal systems on page 89.

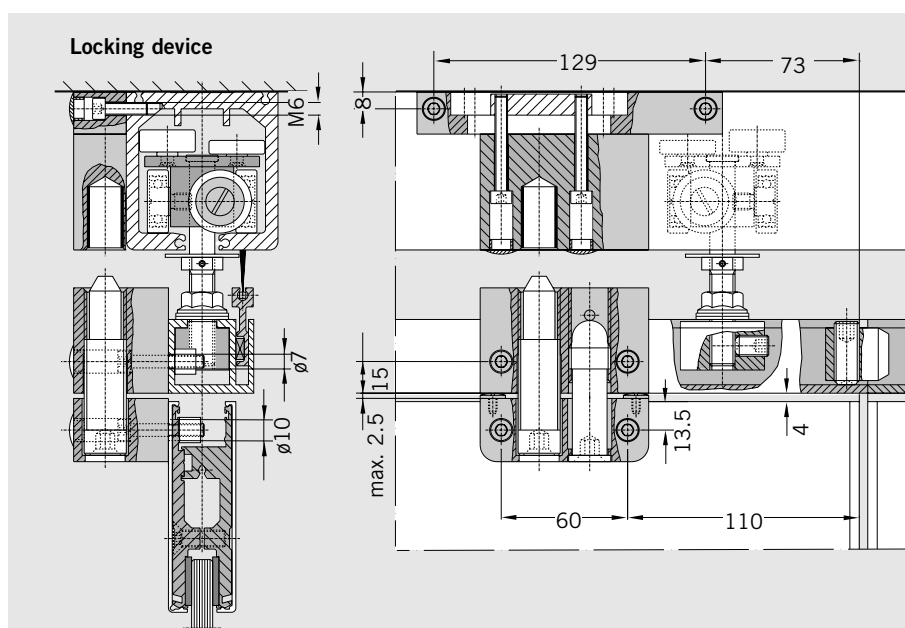
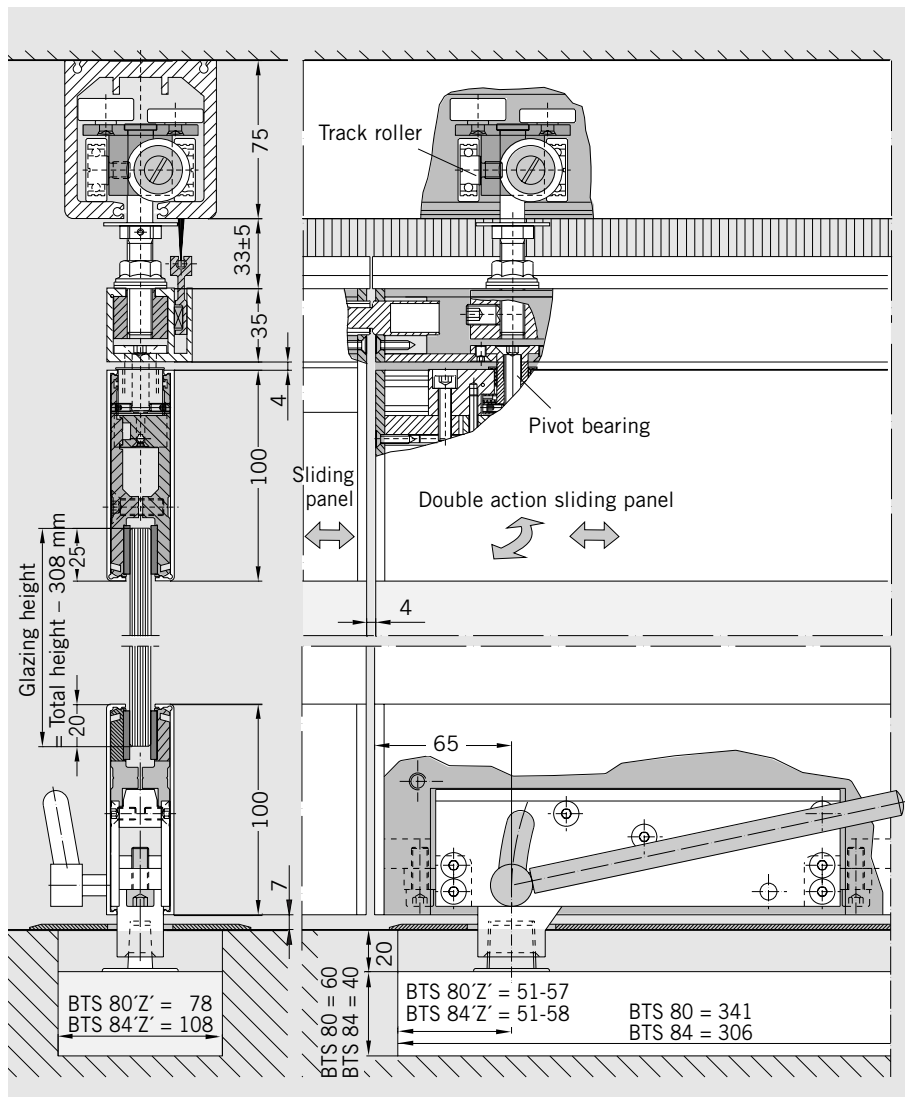
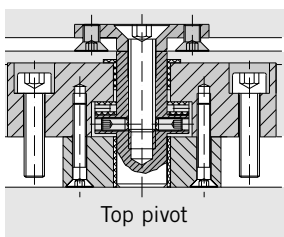

Double action sliding panel

Pivoting panel with RTS transom door closer for operation as a double action door when the frontage is closed.

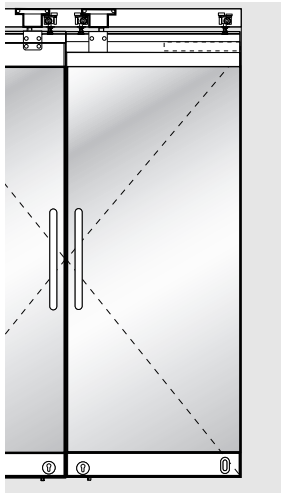

Double action sliding panel with integral DORMA RTS transom door closer

Double action sliding panels with DORMA RTS transom door closers (patented design) are characterised by their exceptional ease of installation and operation; an excellent alternative to the solution with the BTS floor spring because the RTS does not require a large recess in the floor. These panels are generally equipped with a bottom deadlock and top locking device plus a bottom face-mounted slide bolt operating as the pivot bearing (released for the sliding function).

The standard solution takes the form of the RTS 85 without hold-open, or as a special option, with a 90° hold-open.

For these panel types please consider our notes on portal systems on page 89.

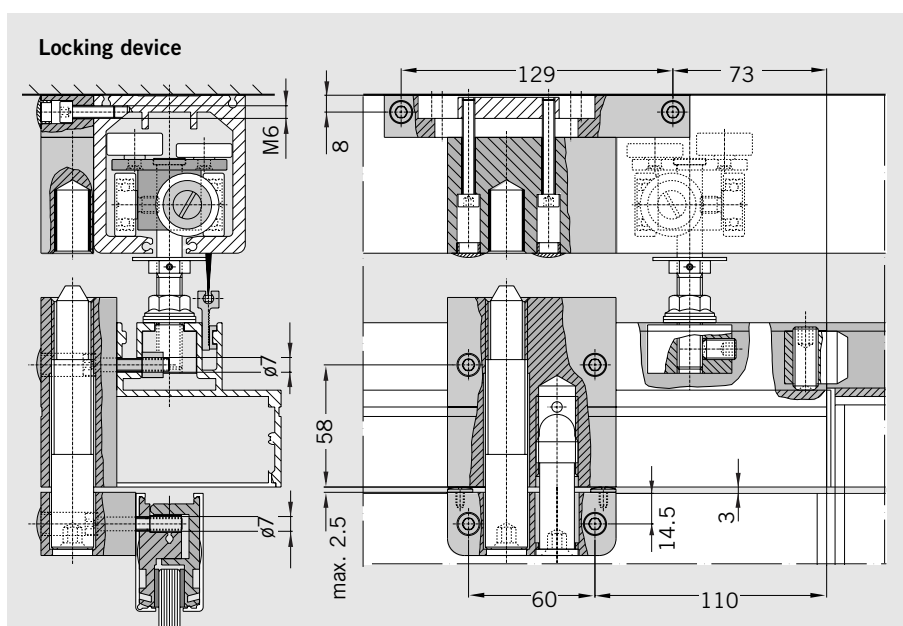
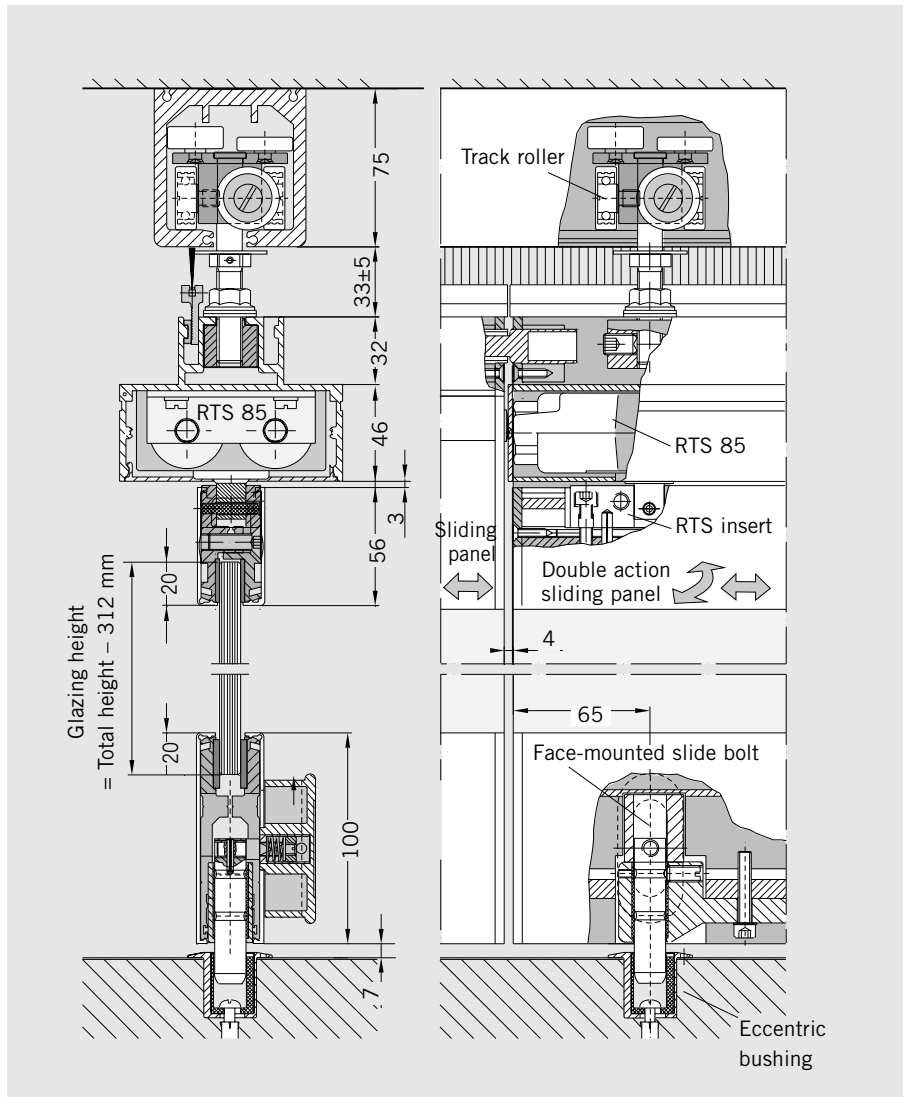

Single action door

Single action panel, non-sliding, operates independently of the rest of the system.

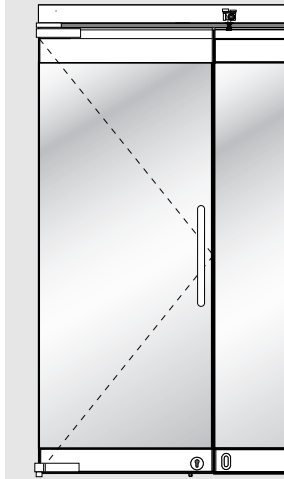

The single action door with offset pivoting arm assembly can be swung around 180°, so leaving the entire operating zone free. A bottom deadlock secures the closed leaf.

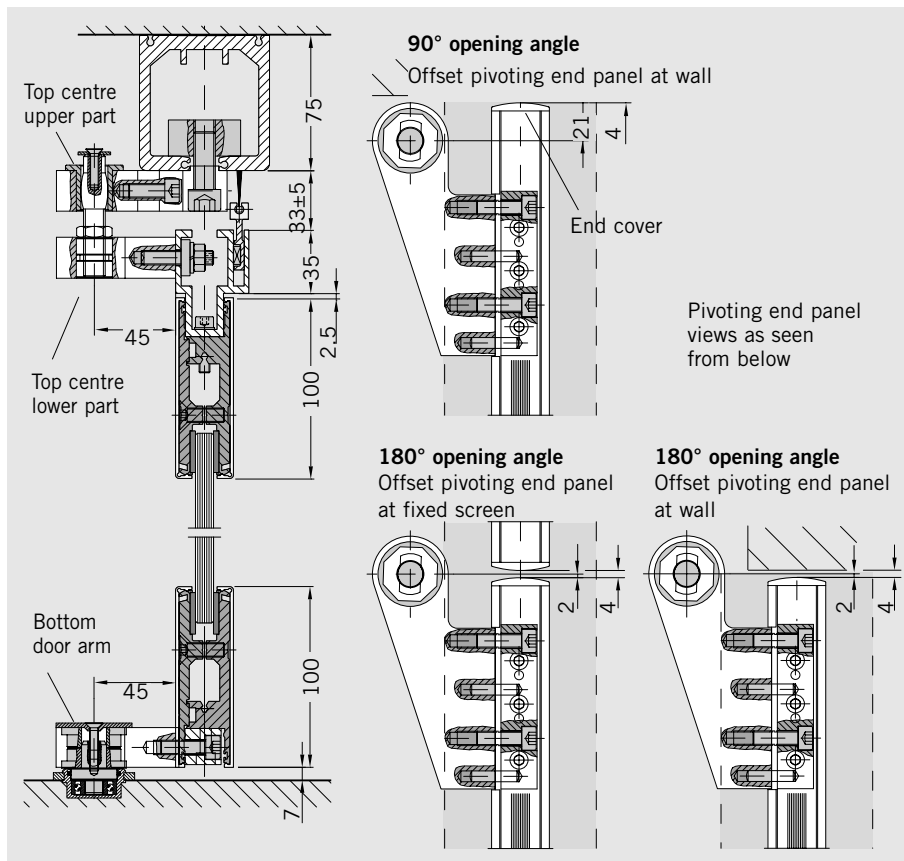

Fixed side screen

Non-moving side screen, independent of the rest of the system.

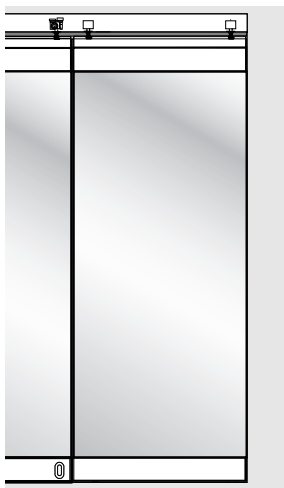

The fixed side screen is of the same basic design as the sliding panels. And if required, the fixings can be replaced by a carrier system to convert such a screen into a sliding panel.

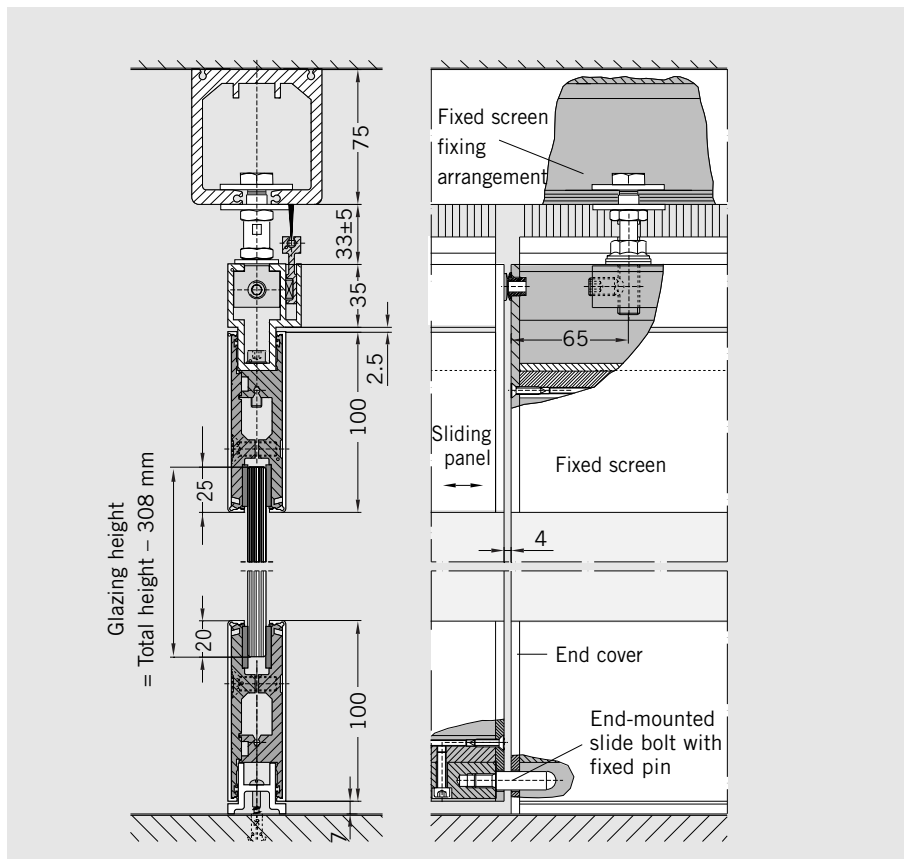

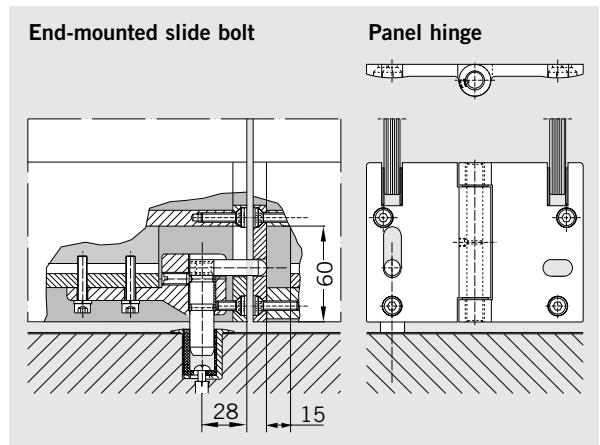
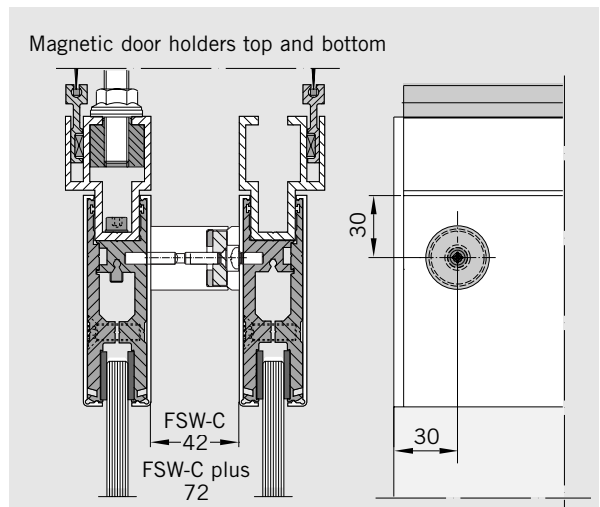
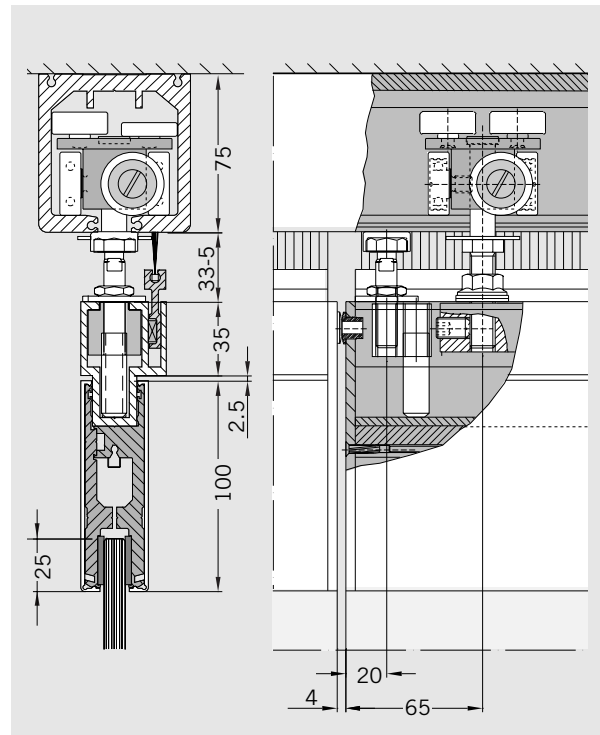
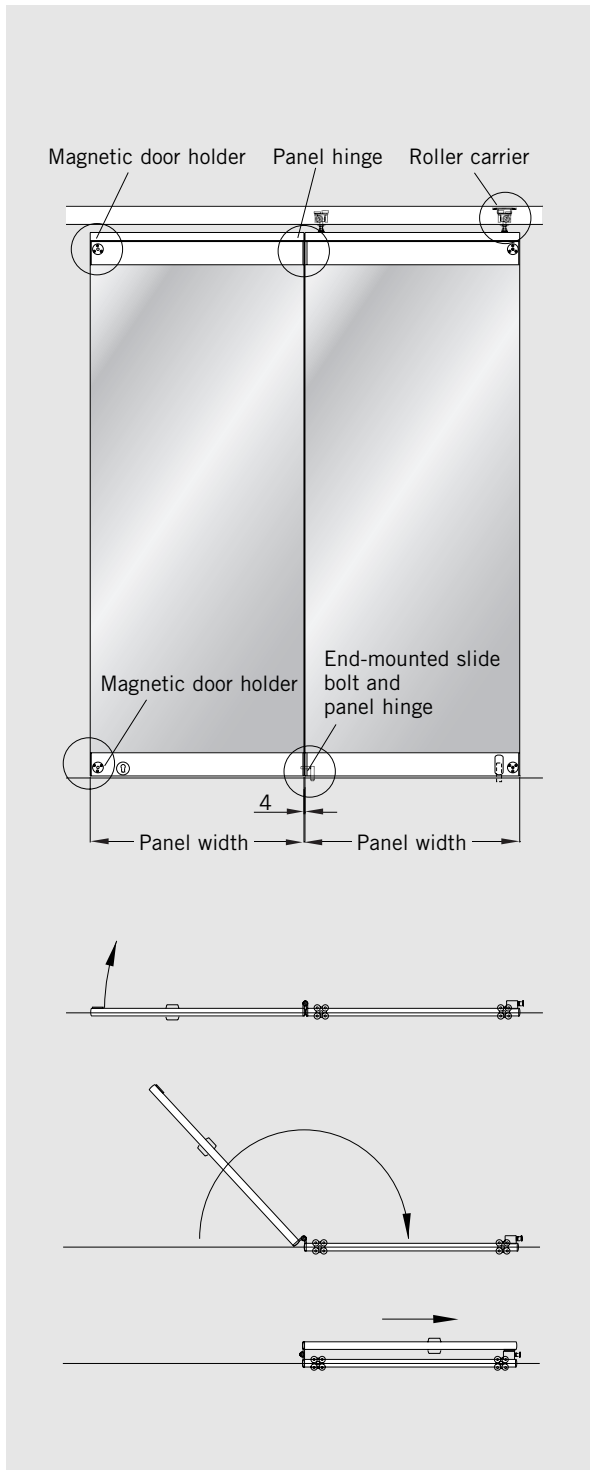

Folding sliding panel

Hinged, with lock and slide bolt at the bottom, latching bolts top and bottom for fixing the final folding panel to the slide panel.

Max. panel sizes and weights

Max. panel width 2 x 1000 mm

Max. system height 3000 mm

Max. panel weight 2 x 70 kg

HSW-GP panels and functions

Fully glazed sliding walls with point-fixed track roller carriers engaging in standard track rail



The characteristic features of HSW-GP systems are the single-point fixings of the glass panels in combination with a conventional track rail profile. The design, featuring a high-grade stainless steel finish and the distinctive flush-mounted attachments, coordinates perfectly with contemporary architecture. Even curved glazing can be securely held by this system. And this can also be combined with curved track rail profiles to produce unique configurations.

Max. panel sizes and weights

Max. system height	3000 mm	3000 mm	3000 mm	3000 mm
Max. panel width	1200 mm	1200 mm	1200 mm	1200 mm
Max. panel weight	100 kg	100 kg	100 kg	100 kg

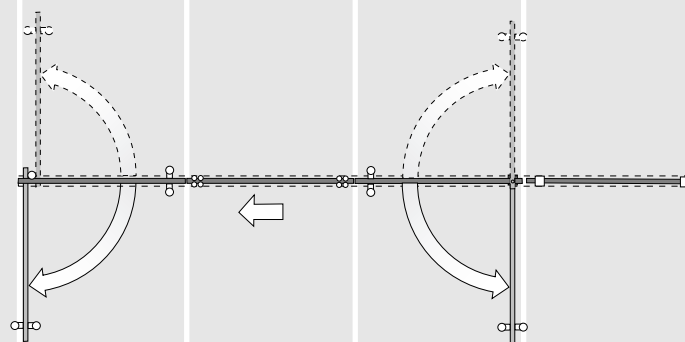
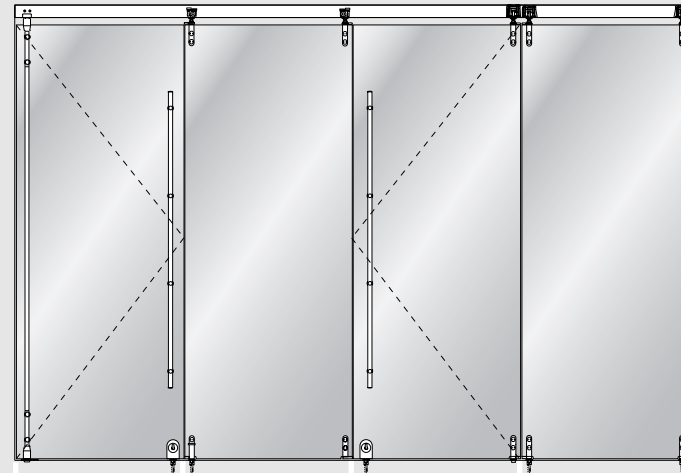

Single/double action end panel

Non-sliding. With full-length pivot rod and offset pivot. Single action panel with floor pivot, round spindle and stop. Double action panel with floor pivot or BTS floor spring.

Sliding panel

Fixed when frontage closed.

Single/double action end panel

Non-sliding. With centre pivot top and bottom. Single action panel with floor pivot, round spindle and stop. Double action panel with floor pivot.

Fixed screen

Non-sliding. Fixed side screen with retaining pins at the top and fixed screen straps at the bottom.

The individual panels can also be of differing widths. The largest width should not exceed max. 115% of the smallest width.

HSW-GP system design

The HSW-GP system consists of the following basic components:

- 1 installation-efficient DORMA substructure to accommodate track rail mounting requirements (optional).
- 2 track rail for bolting to the substructure.

- 3 roller,
- 4 suspension assembly,
- 5 strap with single-point fixings,
- 6 toughened safety glass or toughened laminated safety glass (by others),
- 7 bottom strap with end-mounted pin,
- 8 bottom strap with face-mounted slide bolt.

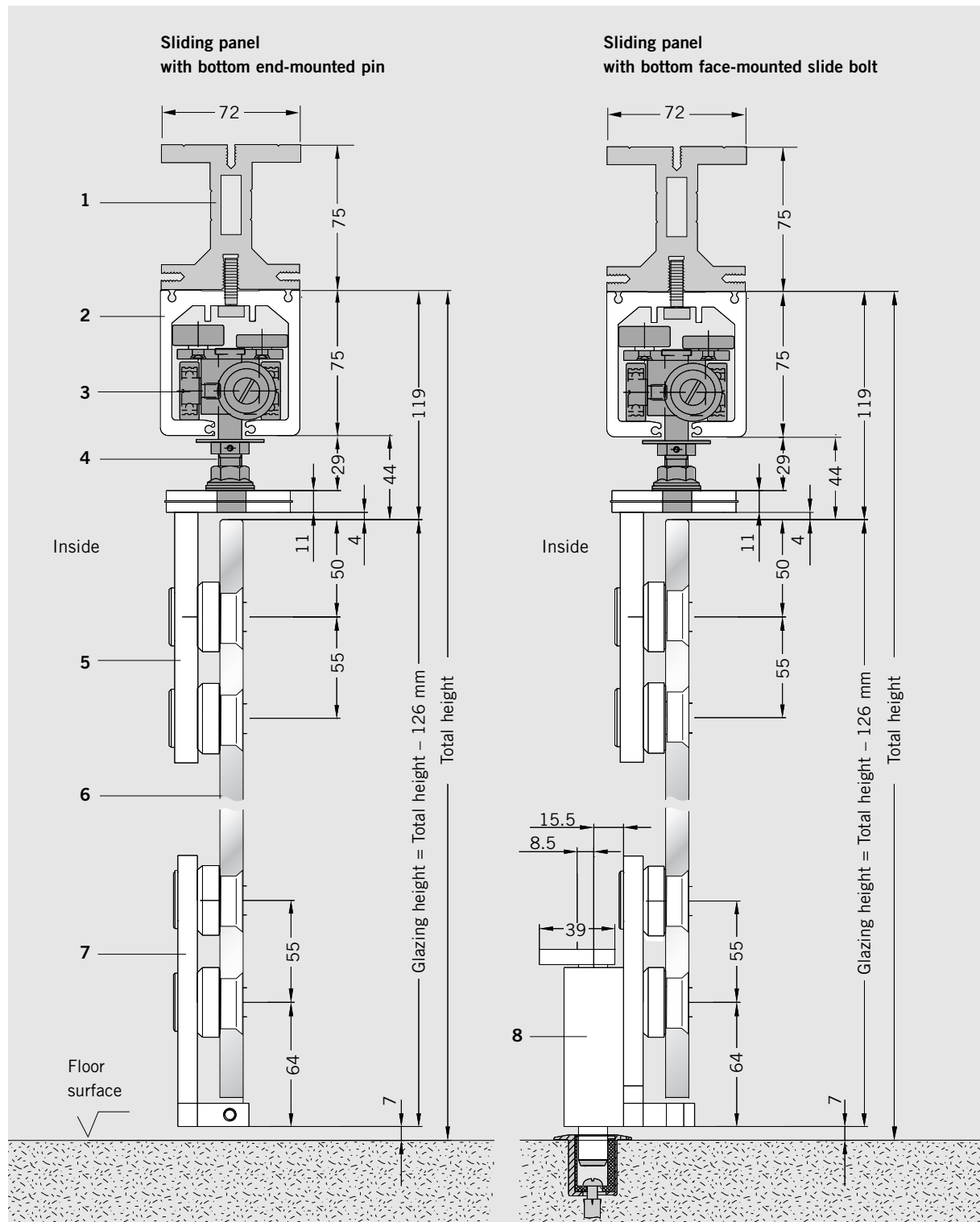

HSW-GP panel types and glass drilling requirements

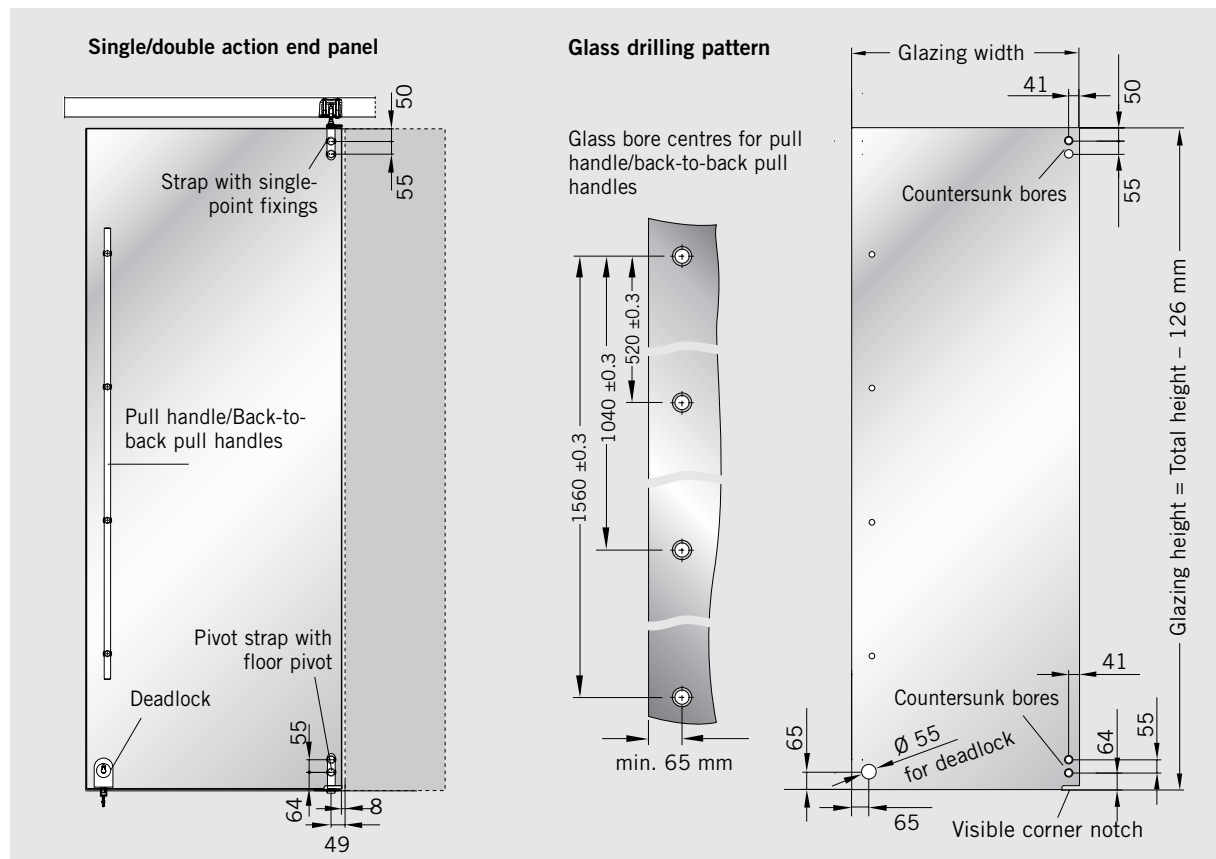
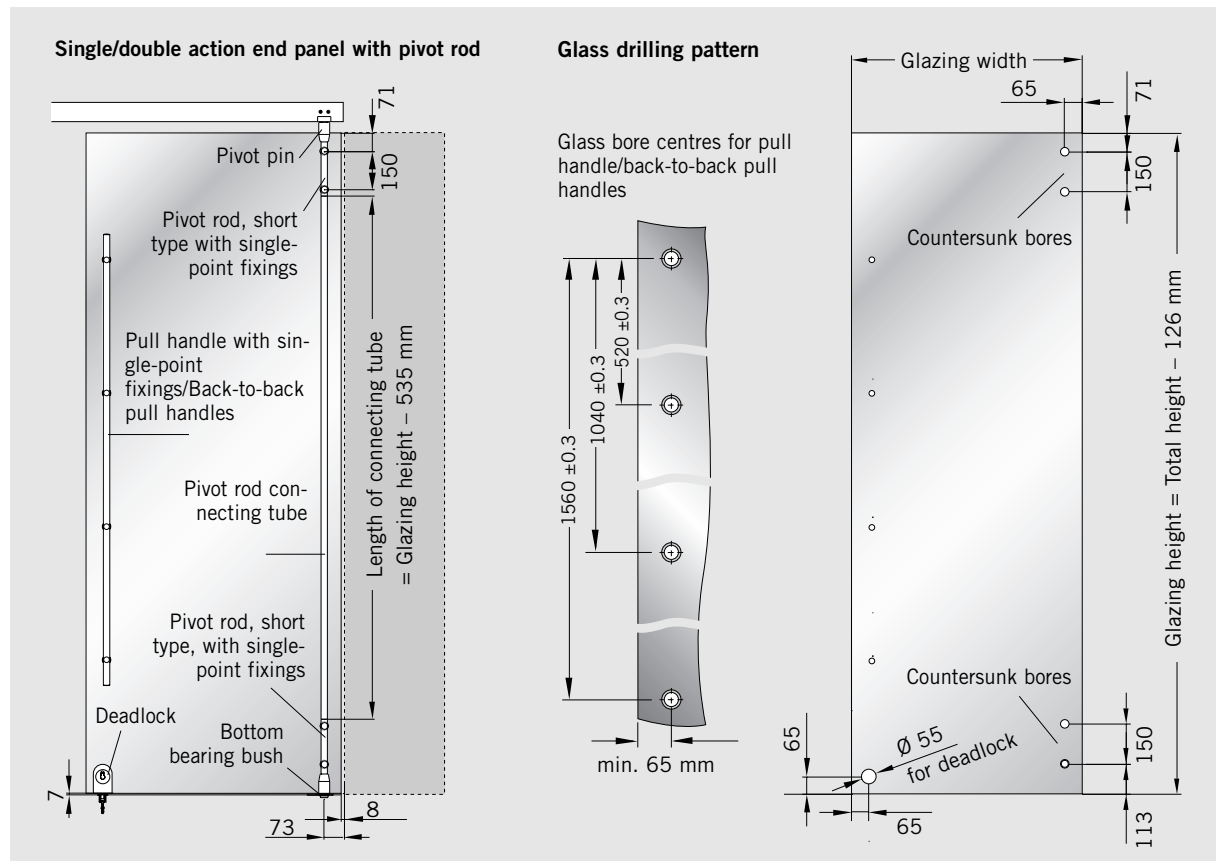

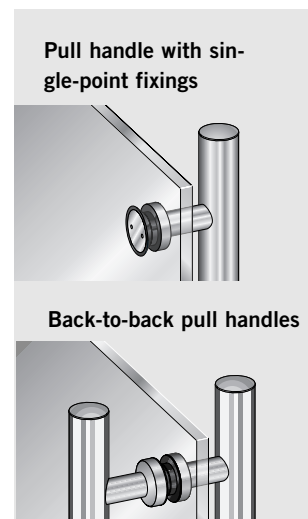
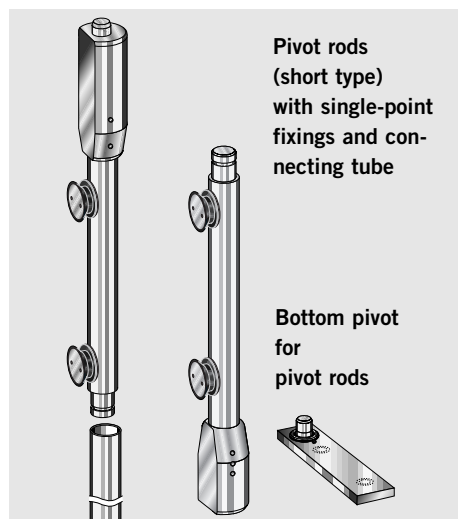
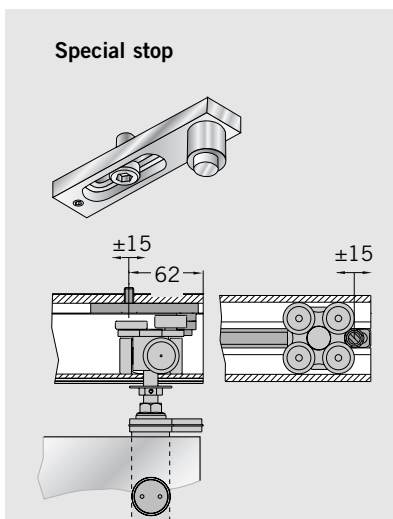
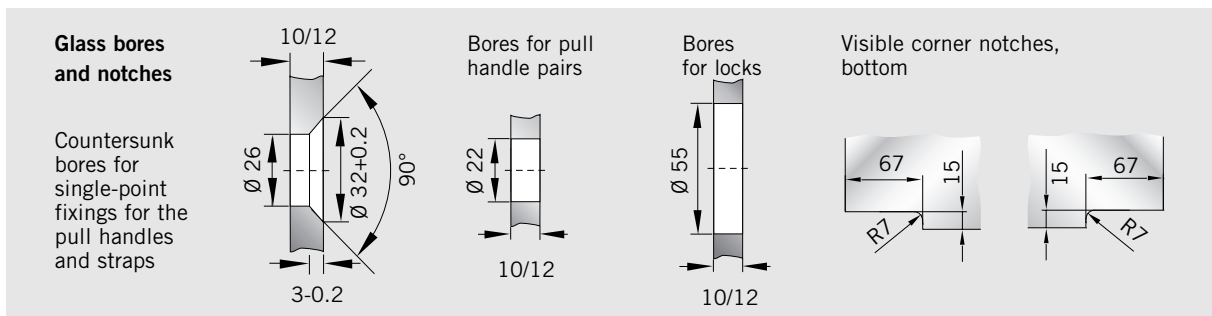
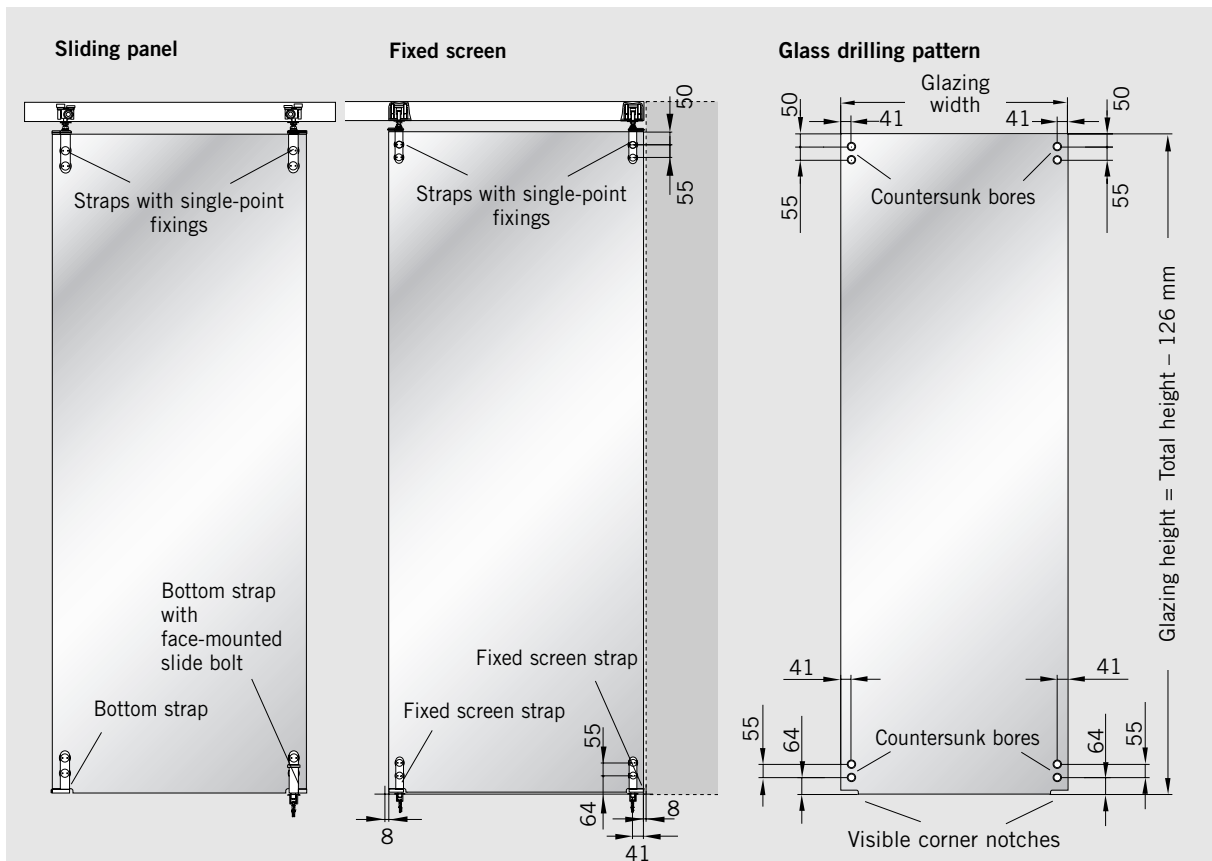

HSW-GE BOXes panels and functions

Fully glazed sliding walls with patch fittings



There are six different boxes available for your in-house HSW system planning and design work. Aside from the requisite hardware and fittings, each box also contains the necessary number of eccentric bush-type keeps. The locks contained in the HSW-GE BOXes are equipped exclusively with double Europrofile cylinders so that no LH/RH handing distinction needs to be made in the case of double-action end panels.

The bottom functional elements can be installed on either side of the panels using the different fittings provided. When designing stacking/parking areas, please ensure compliance with the instructions provided in this technical brochure (available under WN No. 800.51.024.6.32) on pages 46 and 47.

Max. panel sizes and weights

Max. system height	3000 mm	3000 mm	3000 mm	3000 mm
Max. panel width	1100 mm	1100 mm	1100 mm	1100 mm
Max. panel weight	80 kg	80 kg	80 kg	80 kg

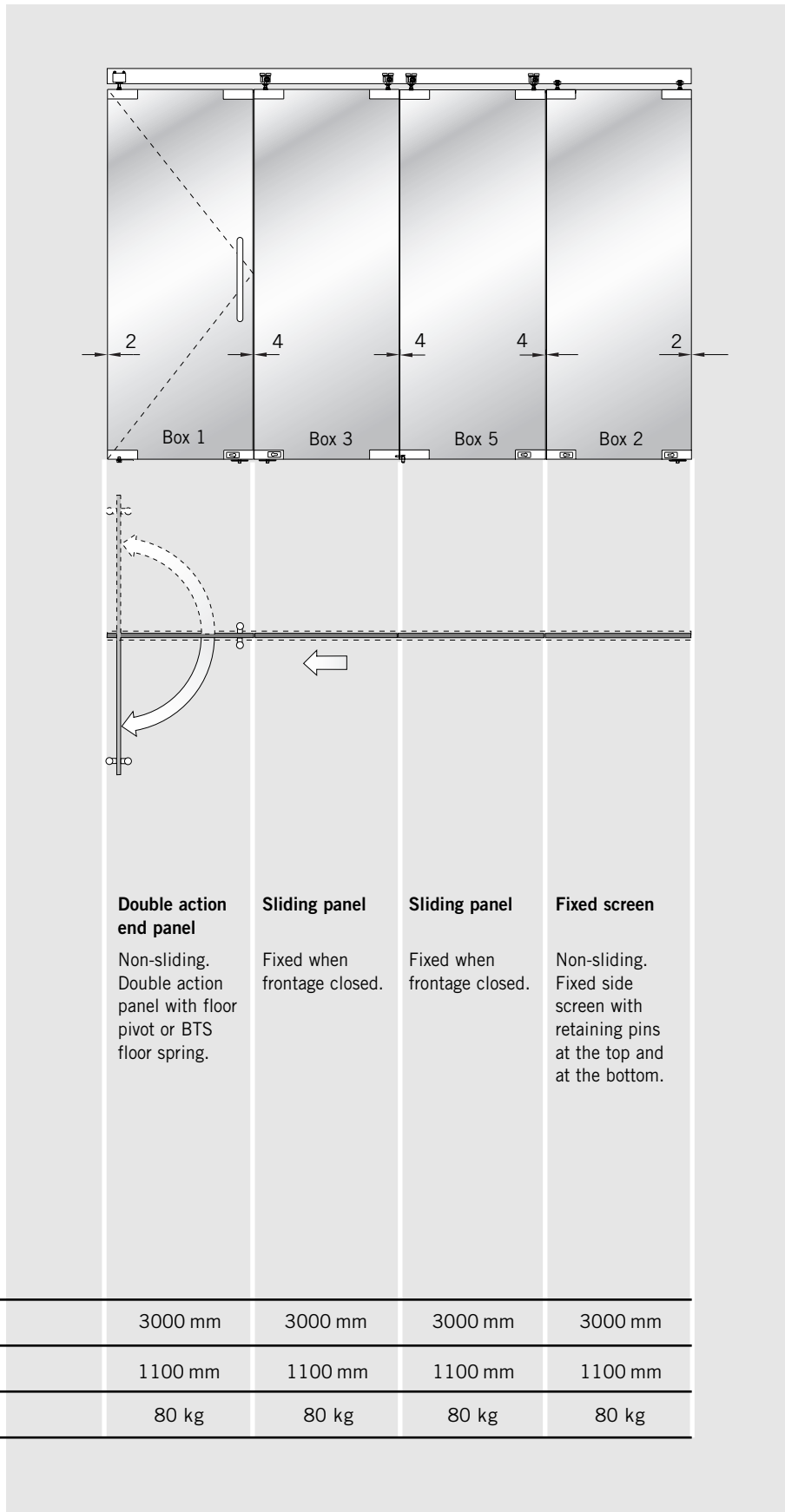

HSW-GE BOX 1

Double action end panel with floor point

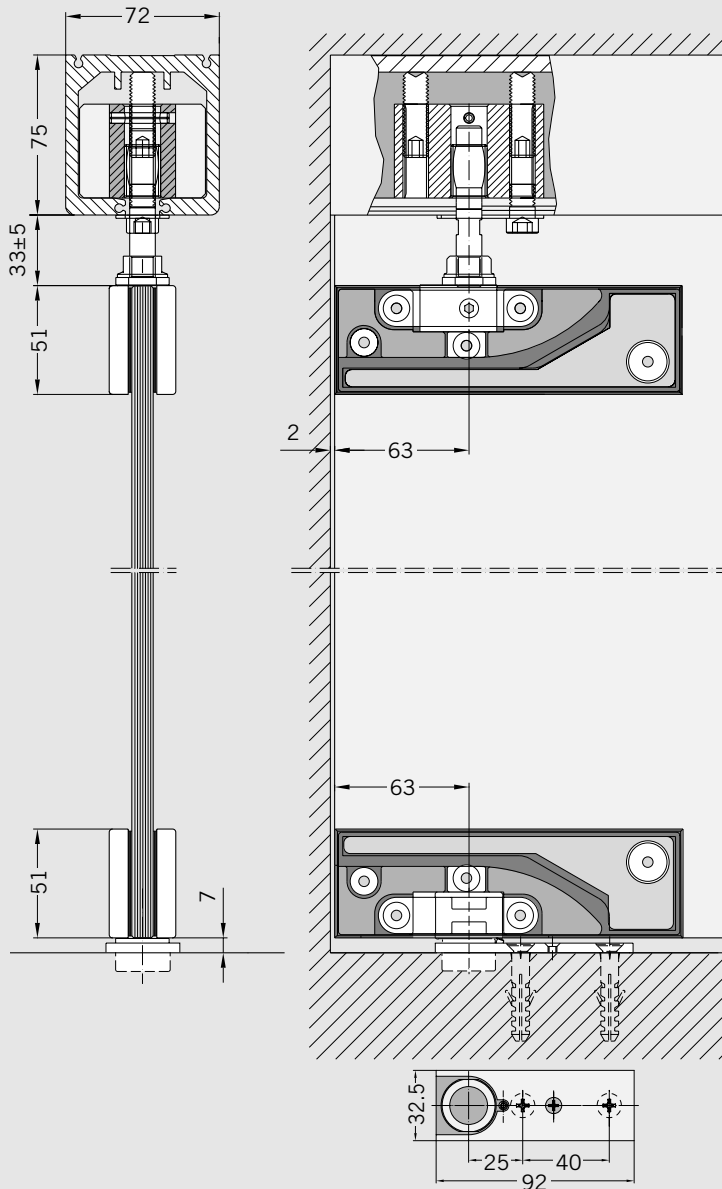

Double action end panel optional with BTS floor spring

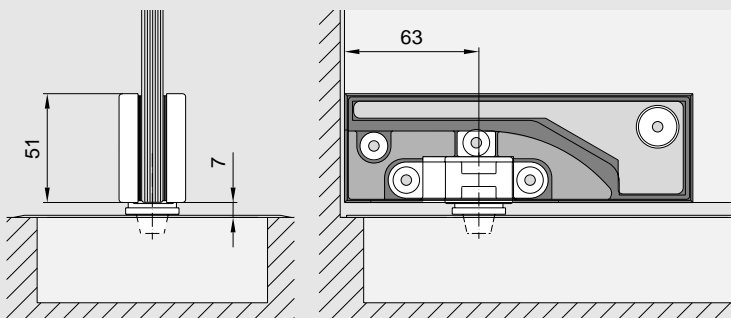

Double-action end panel, non-sliding. Equipped as standard with a top pivot bearing, bottom vertical-action floor lock for double Europrofile cylinder, and bottom pivot with round spindle. Suitable for RH and LH handing.

As an option, a BTS 84 floor spring may be used instead of the bottom pivot.

The BTS 84 is suitable for panels weighing up to 100 kg and can be provided with or without a hold-open device for retention at a 90° door opening angle.

Fitting components
BOX 1

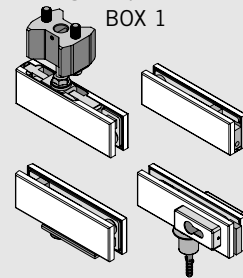

Fittings can be used on both sides.
Note changes in glass preparation/drilling requirements!

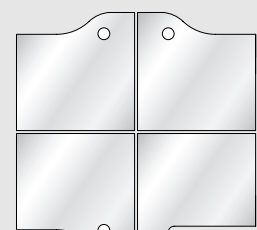
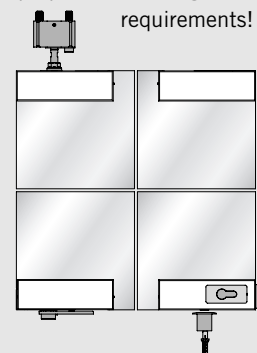

For glass preparation see page 45

HSW-GE BOX 2

Fixed screen with retaining pins

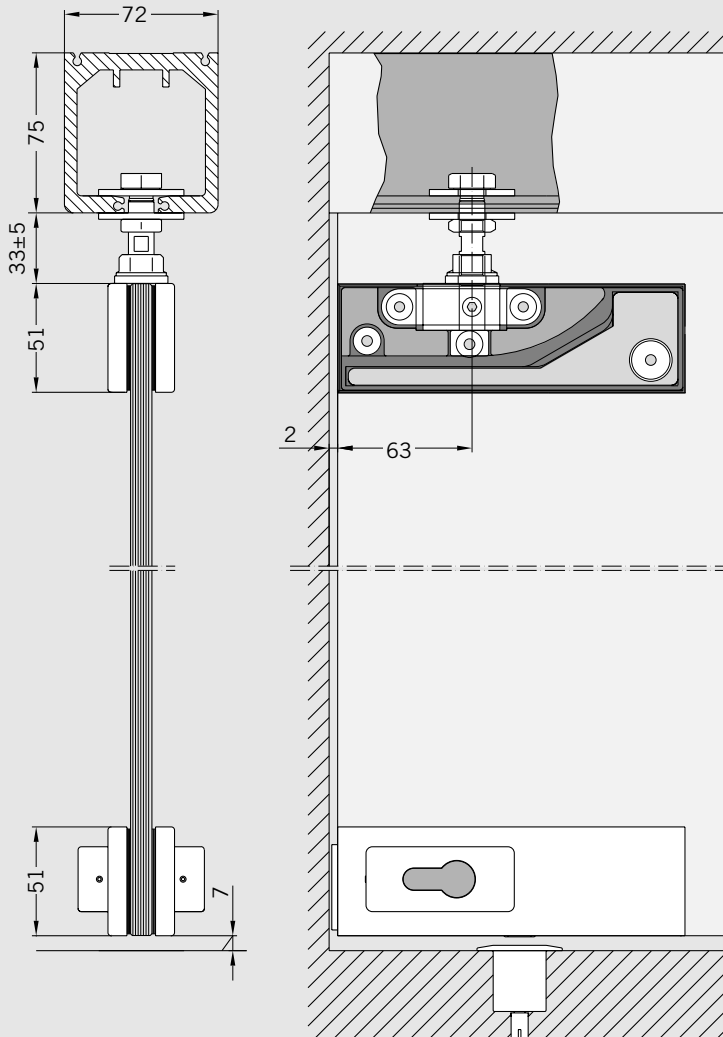

Can also be used as a sliding panel by replacing the fixed screen mounting with a roller carrier.

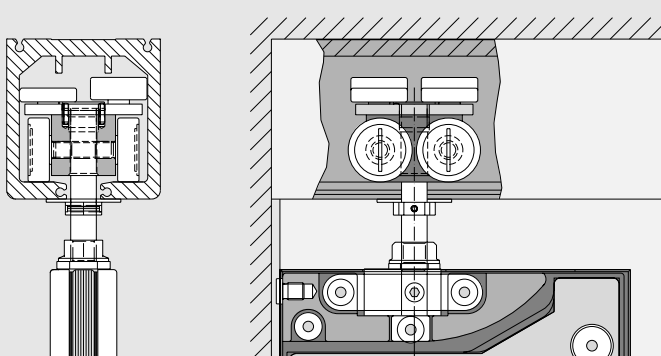

Non-sliding side screen, installed independently of the rest of the system. Equipped as standard with two fixed screen mountings at the top and two vertical-action floor locks for double Europrofile cylinders at the bottom. The fixed screen is of the same visual design as the sliding panels. If required, it can also be converted into a sliding panel by replacing the fixed screen mountings with a roller carrier.

Fitting components
BOX 2

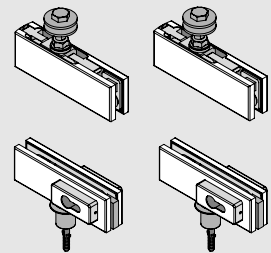

Fittings can be used on both sides.

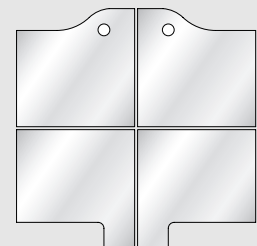
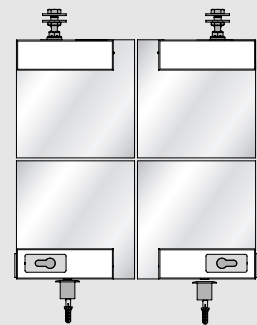

For glass preparation
see page 45

HSW-GE BOX 3

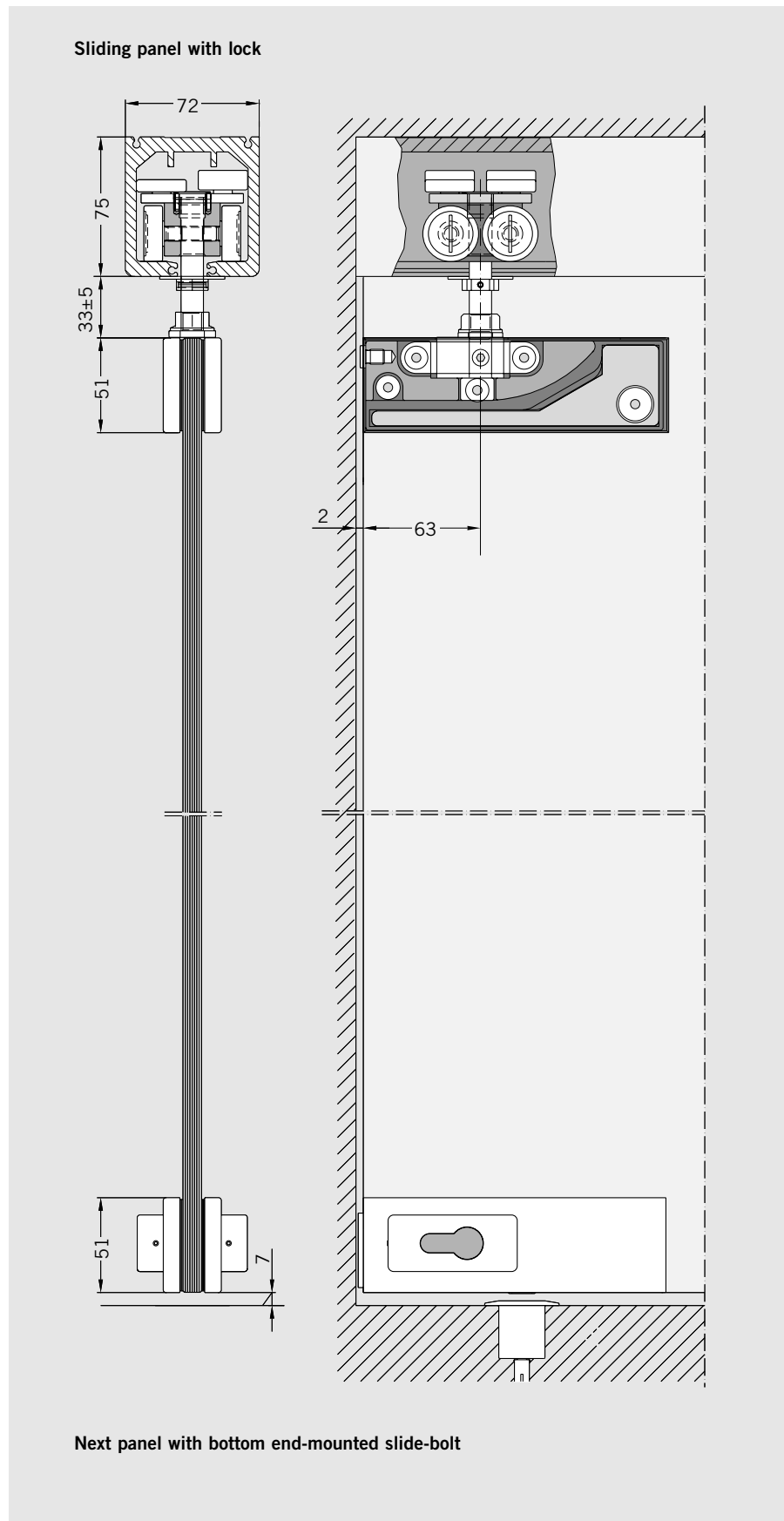

The sliding panels are held in position once the system is closed. Equipped as standard with a vertical-action floor lock for a double Europrofile cylinder, and a keeper for an end-mounted slide bolt.

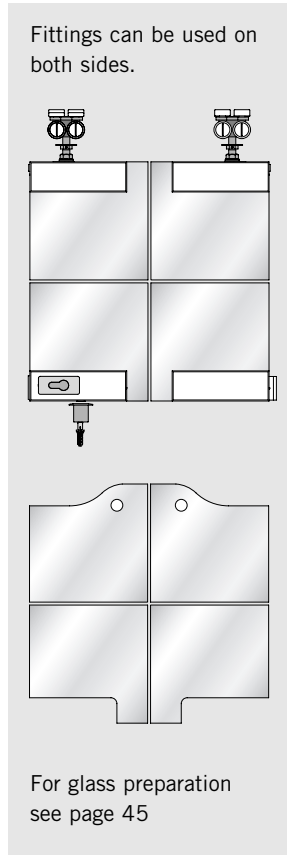
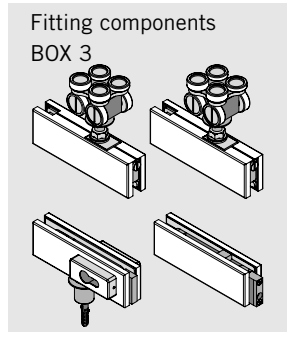

HSW-GE BOX 4

Sliding panel with end-mounted slide bolt

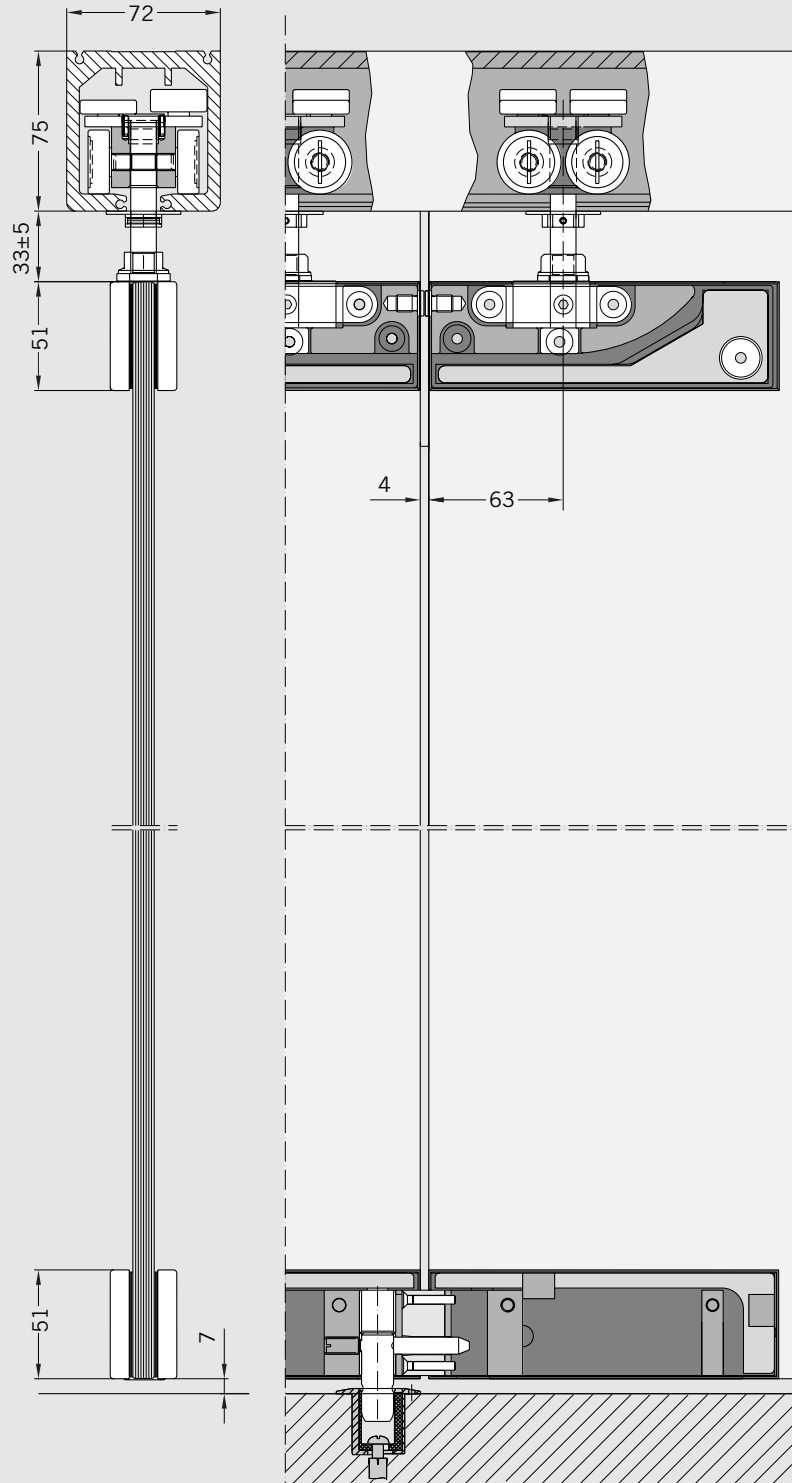

Next panel with bottom end-mounted side bolt

The sliding panels are held in position once the system is closed. Equipped as standard with a keeper for an end-mounted slide bolt and with an end-mounted slide bolt.

Fitting components
BOX 4

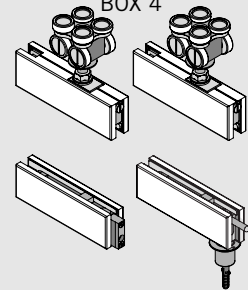

Fittings can be used on both sides.

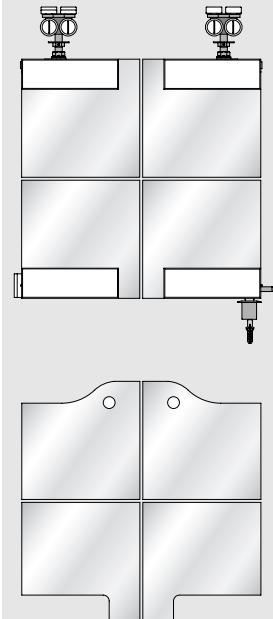

For glass preparation
see page 45

HSW-GE BOX 5

Sliding panel with lock and end mounted slide bolt

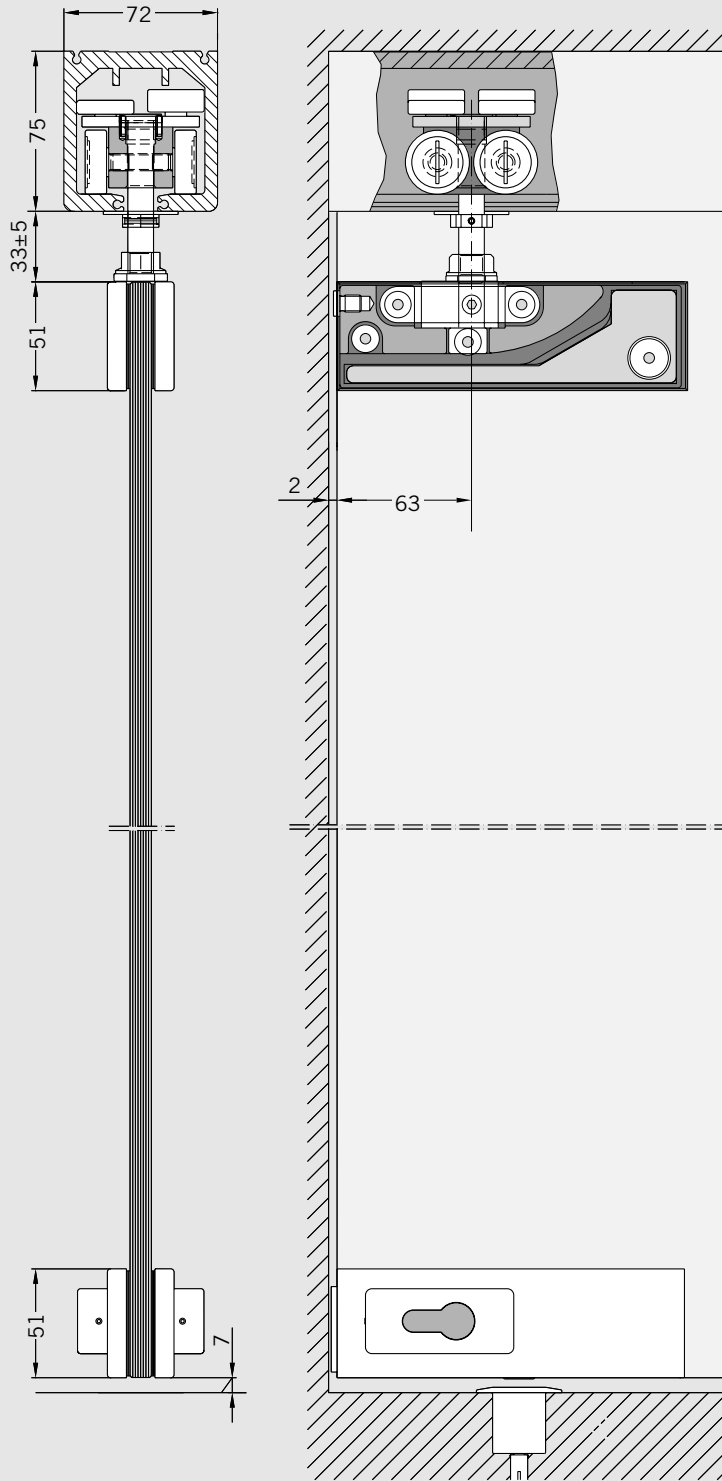

Next panel with end mounted slide bolt receiver for end fixed locking bolt

The sliding panels are held in position once the system is closed. Equipped as standard with a vertical-action floor lock for a double Europrofile cylinder, and an end-mounted slide bolt.

Fitting components
BOX 5

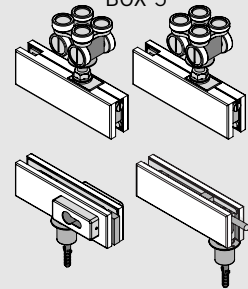

Fittings can be used on both sides.

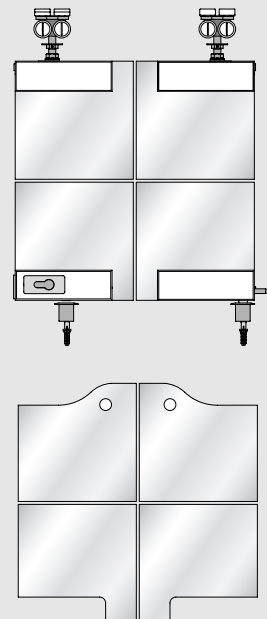

For glass preparation see page 45

HSW-GE BOX 6

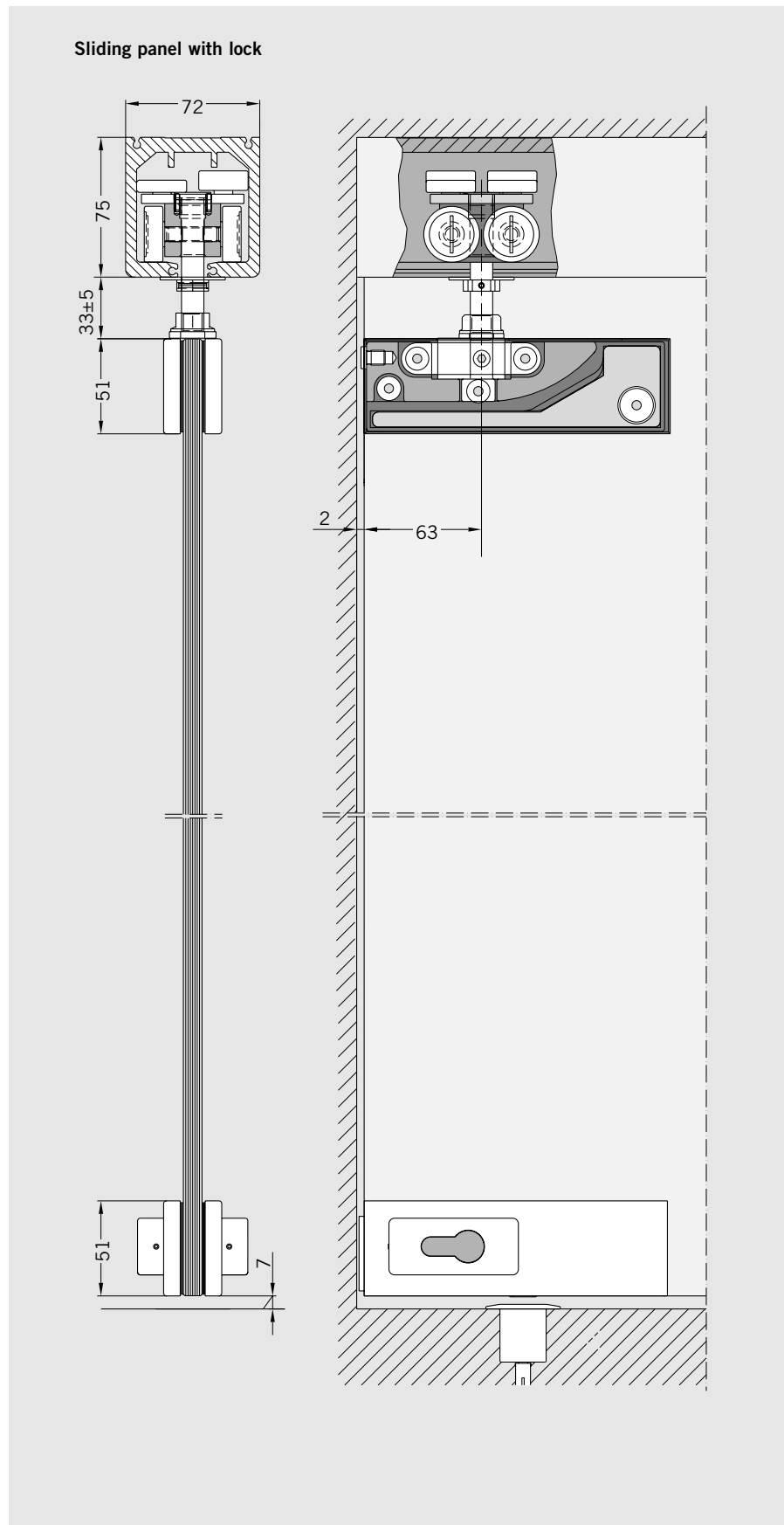

The sliding panels are held in position once the system is closed. Always equipped with two vertical-action floor locks for double Europrofile cylinders.

Fitting components BOX 6

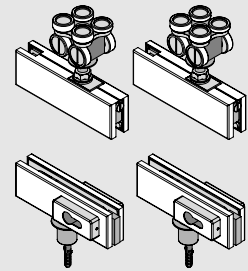

Fittings can be used on both sides.

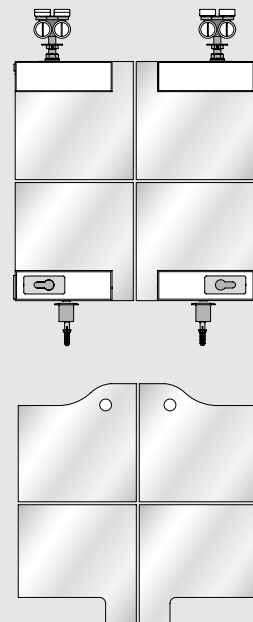

For glass preparation
see page 45

HSW-GE Glass preparation BOX 1 - 6

Top glass panel preparation BOX 1 - 6

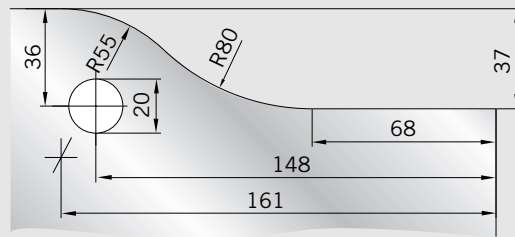
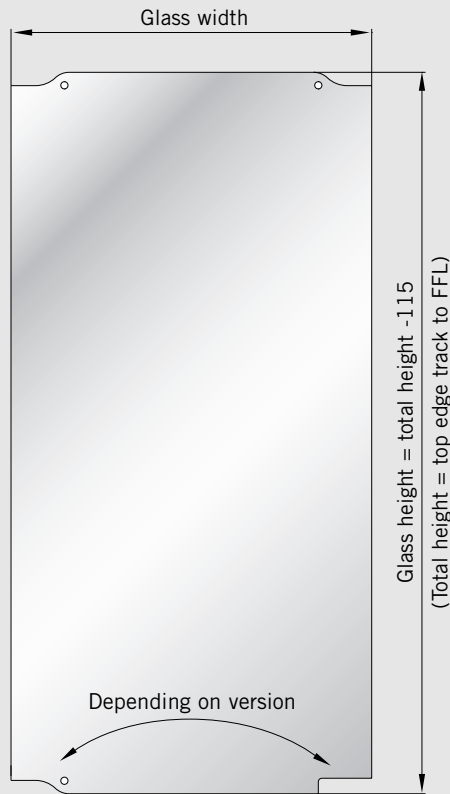

Glass cut-out for:

- top patch fittings GE 20 and GE 30
- bottom patch fitting GE 10 for floor bearing

Bottom glass panel preparation BOX 1

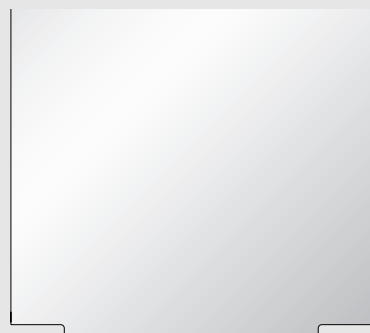

Glass panel preparation bottom BOX 2 - 6

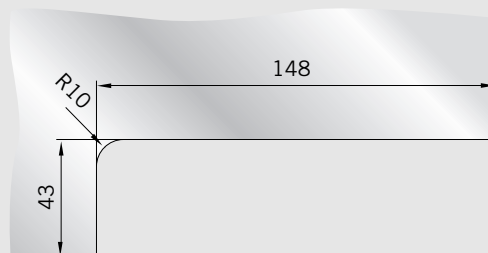

Glass cut-out bottom for:

- GE patch lock
- end-mounted slide bolt
- strike box for end-mounted slide bolt

HSW-GE BOXes 90° Standard stacking track

- Stacking track depth is designed for a maximum of 10 panels (1 x pivoting end panel and 9 x sliding panels).
- In its as-delivered condition, the stacking track width accommodates the maximum panel width ($b = 1100$ mm).
- Adjustment to actual panel width is accomplished using track rail section B2. This track rail section is non-welded in its as-delivered condition and is connected to the track rail modules by means of pins ($L = 50$ mm).

Straight track rail with stacking position transverse to travel direction (90°)

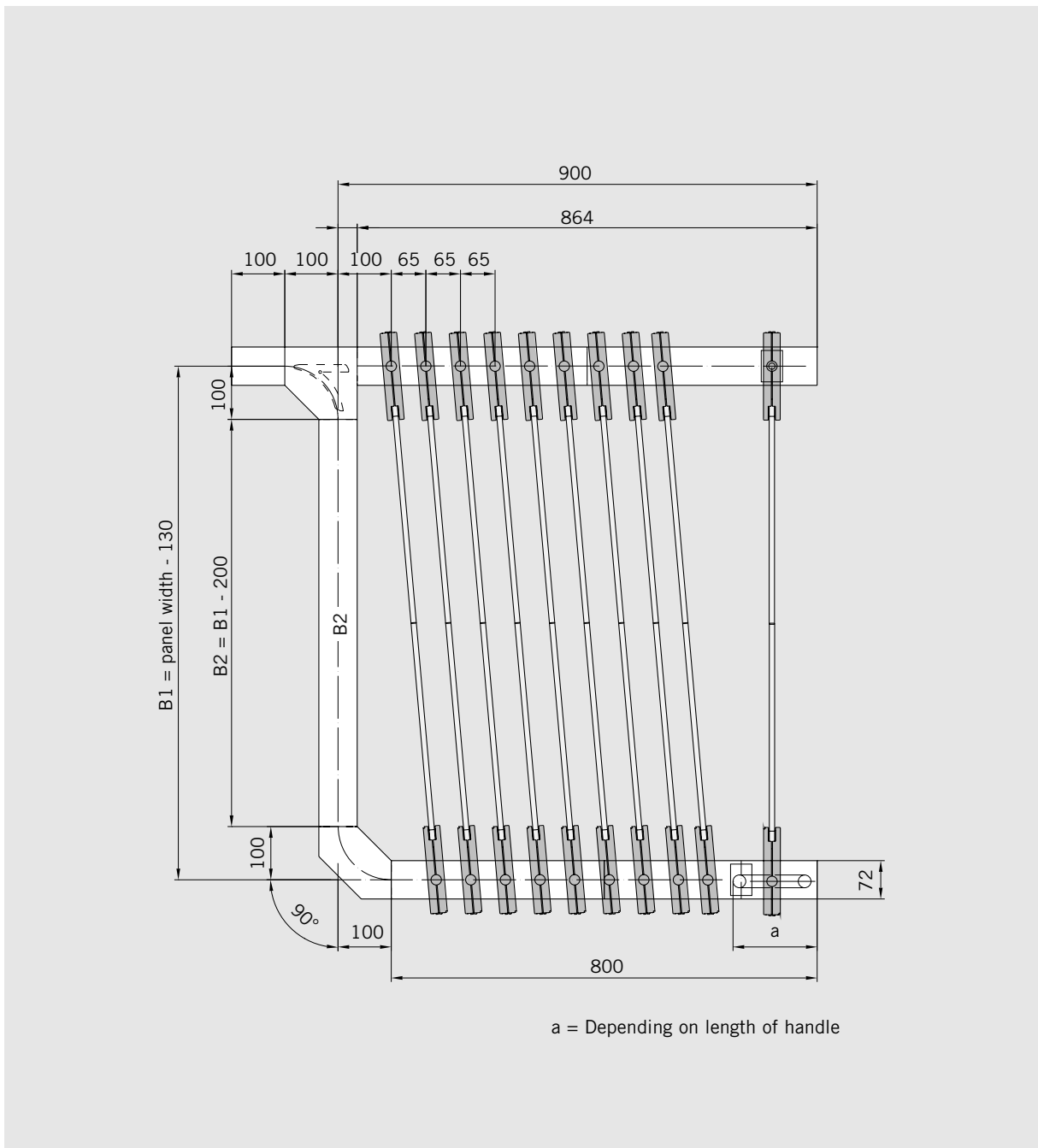

HSW-GE BOXes Standard stacking track parallel to direction of travel

- The depth of the stacking track is designed for a maximum of 10 sliding panels.
- A pivoting end panel is also envisaged as a means of accessing the parking position.
- In its as-delivered condition, the stacking track width accommodates the maximum panel width ($b = 1100$ mm).
- Adjustment to actual panel width is accomplished using track rail section B2. This track rail section is non-welded in its as-delivered condition and is connected to the track rail modules by means of pins ($L = 50$ mm).

Straight track rail with stacking position parallel to travel direction

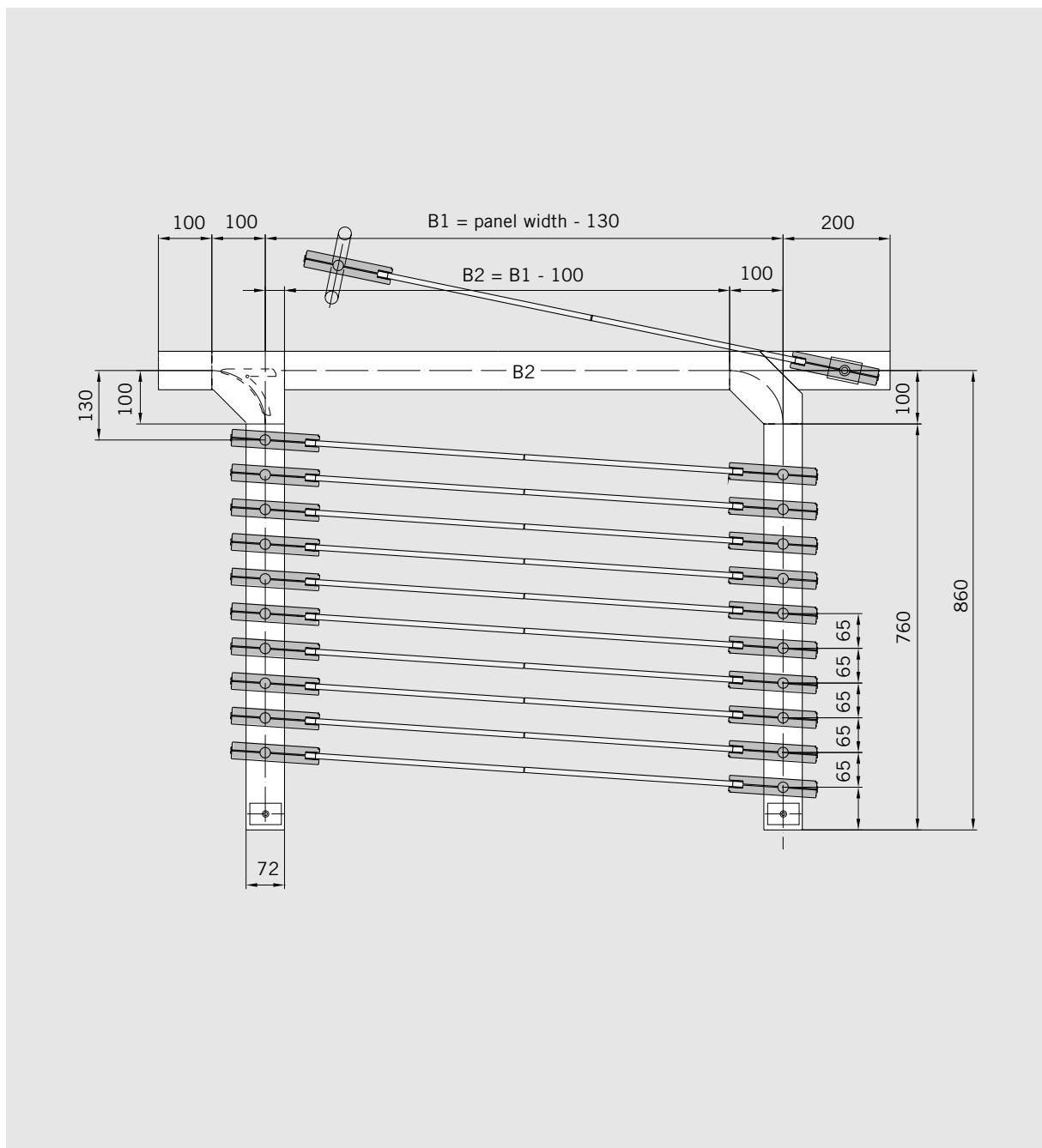

FSW-G panel types and functions

FSW folding sliding walls as fully glazed partitions and frontages, with door rails top and bottom, track roller position at the end of every second panel.



Folding sliding walls are ideal for a straight-line system configuration. Because the panels of an FSW system are visually compatible with the HSW-G panels, both system types can use the same track rail construction and can be effectively combined within a single frontage. Consequently, an FSW system can also be complemented through the addition of a free-standing HSW double action or single action end panel.

An FSW system essentially contains the following hinged components:

- 1 FSW end assembly with 1 or 3 folding panels

Two counter-running systems can be combined to create frontages with 8 panels.

Max. panel sizes and weights

Max. system height 3000 mm

Max. panel width 1000 mm

Max. panel weight 70 kg

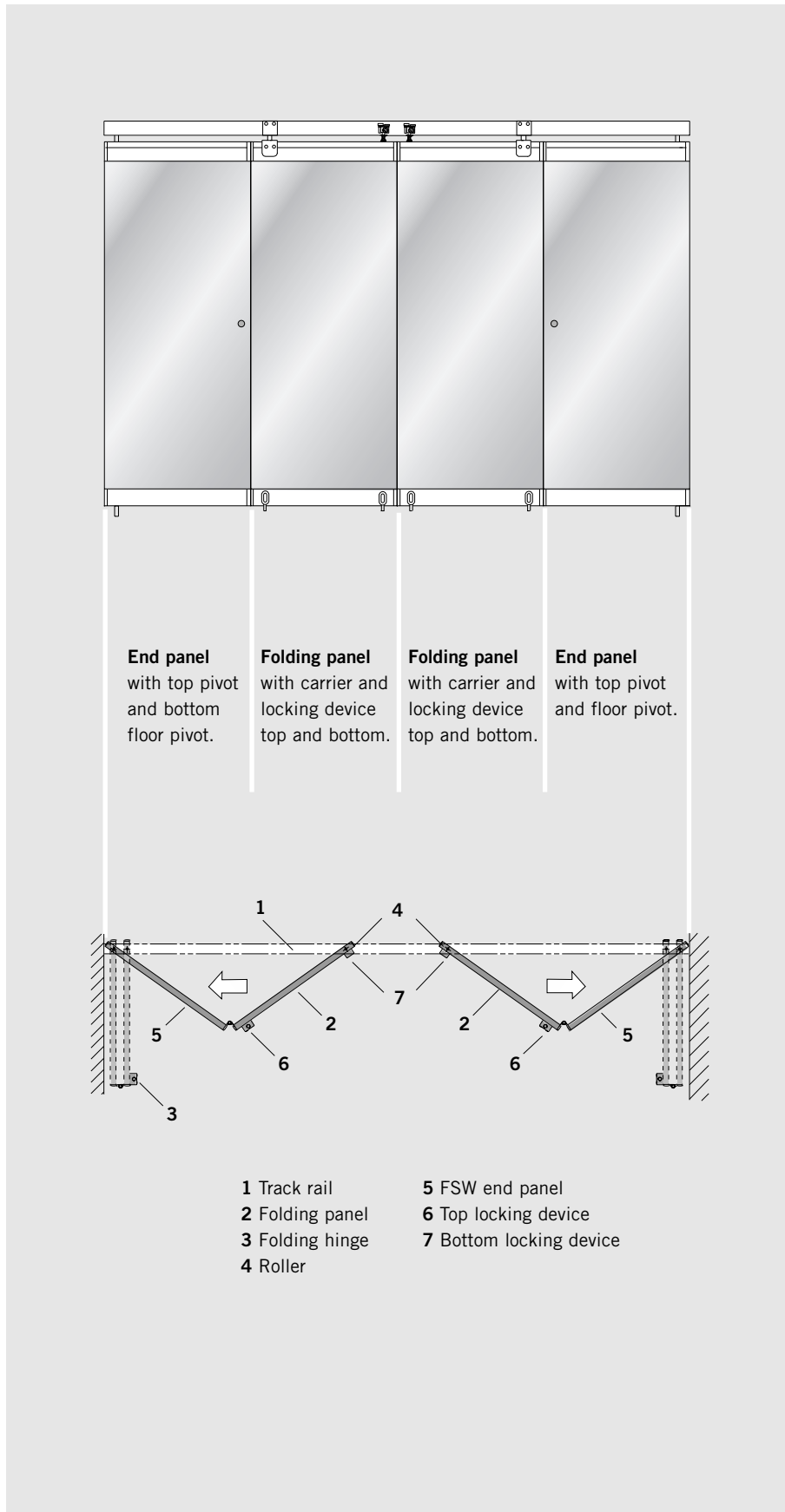

FSW-G system design

The FSW-G system consists of the following basic components:

- 1 installation-efficient DORMA substructure to accommodate track rail mounting requirements (optional).
- 2 track rail for bolting to the substructure.
- 3 top pivot,
- 4 roller,

- 5 top locking device,
- 6 suspension assembly and
- 7 carrier profile for safe and easy sliding of the panels.
- 8 folding hinge,
- 9 top door rail and
- 10 bottom door rail, both

- comprising base profiles with clip-on face and side covers.
- 11 toughened safety glass or toughened laminated safety glass (by others),
- 12 floor pivot,
- 13 face-mounted slide bolt

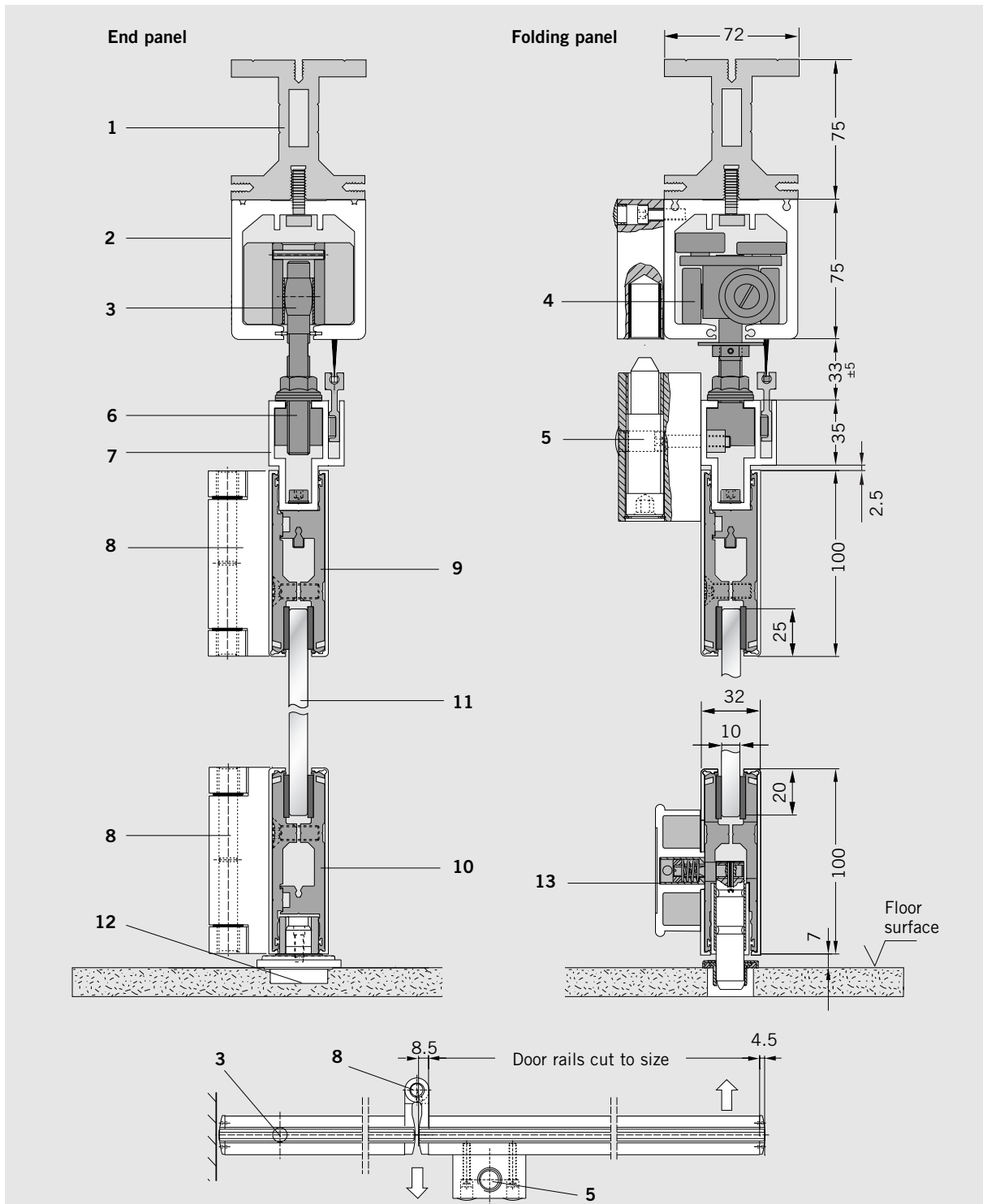

FSW-G assembly types

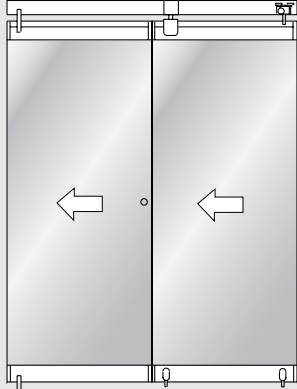

Type 1

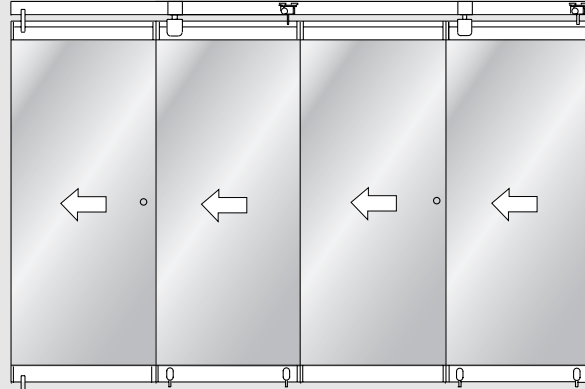

Type 2

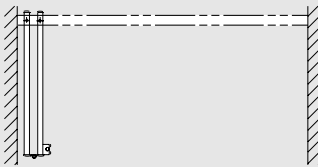

- Type 1a** 2 folding panels left (as drawn)
- Type 1b** 2 folding panels right (mirror arrangement)
- Type 1c** 4 folding panels (2 panels left and 2 panels right)

- Type 2a** 4 folding panels left (as drawn)
- Type 2b** 4 folding panels right (mirror arrangement)
- Type 2c** 8 folding panels (4 panels left and 4 panels right)

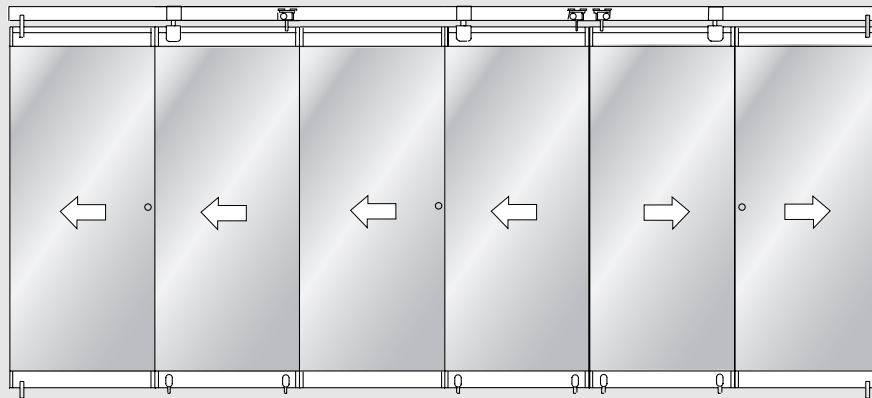

Type 3

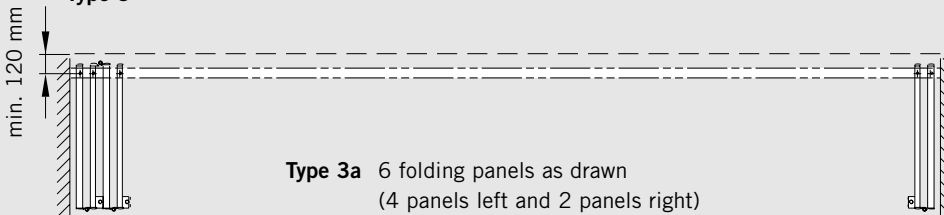

- Type 3a** 6 folding panels as drawn (4 panels left and 2 panels right)
- Type 3b** 6 folding panels, mirror arrangement (2 panels left and 4 panels right)

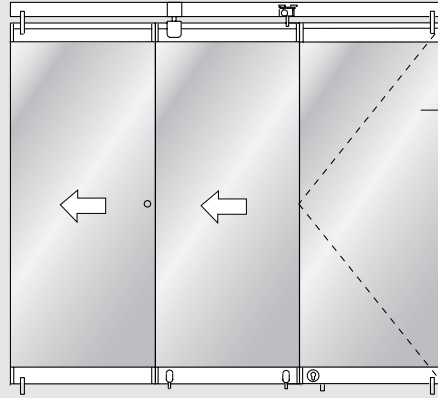

Type 4

HSW end panel
(Access leaf)

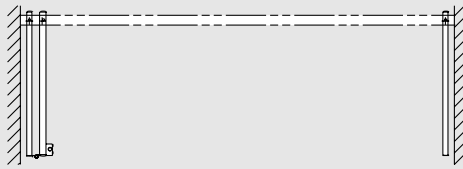

Type 4a 2 folding panels left and
1 access leaf right (as drawn)

Type 4b 2 folding panels right and
1 access leaf left (mirror arrangement)

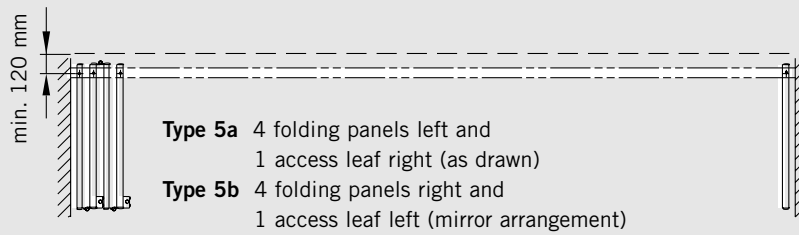
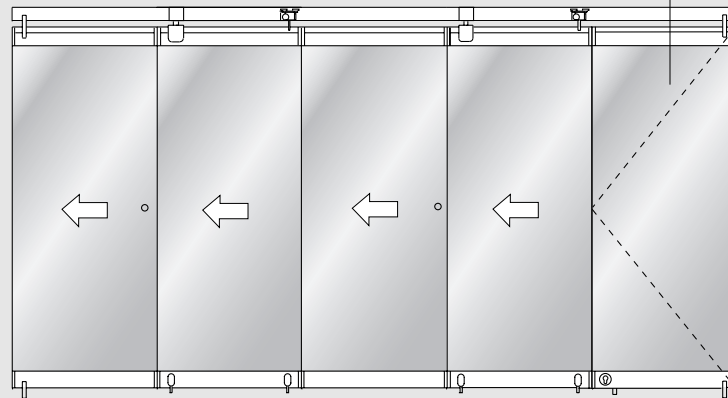

Type 5a 4 folding panels left and
1 access leaf right (as drawn)

Type 5b 4 folding panels right and
1 access leaf left (mirror arrangement)

FSW-C panels and functions

Folding sliding walls, fully glazed, with door rails top and bottom, track roller position in the panel centre.

Large spans can be implemented with the FSW-C. The number of panels per system can be freely selected between 3 and 8. Thanks to the central suspension point, pairing is not necessary. Double systems with two counter-running assemblies can also be installed.

The panels are guided on a sturdy track rail fixed to the ceiling. An additional floor track is not necessary, so the floor covering can be laid without interruption.

Folding sliding walls require a half-width base panel fitted with pivot bearings, to which the folding panels are connected. In order to maintain system symmetry, the final folding panel without a track roller is also of half-width design.



The hinges exhibit a slight pivot offset. This ensures that the folded assembly is particularly compact while at the same time providing for good stability.

Max. panel sizes and weights

Max. system height 3000 mm

Max. panel width 1000 mm

Width of the base panel
= half panel width + 63 mm

Max. panel weight 70 kg

Number of panels 3 to 8

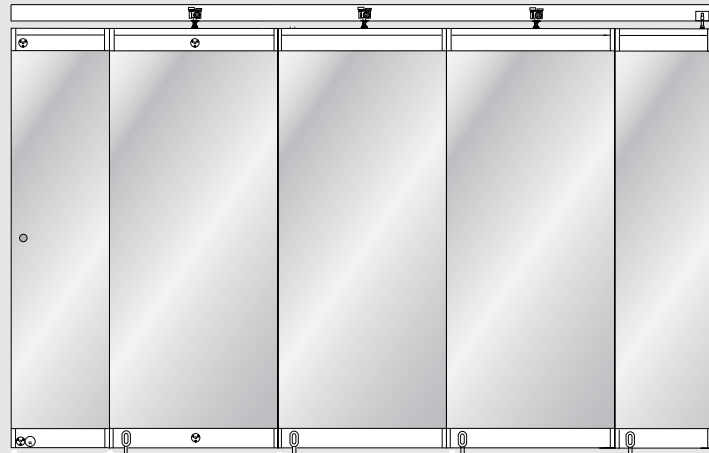

Final folding panel
with locking devices top and bottom.

Folding panel
with carrier, locking devices top and bottom.

Folding panel
with carrier and locking device bottom.

Folding panel
with carrier and locking device bottom.

Base panel
with floor pivot and locking device bottom.

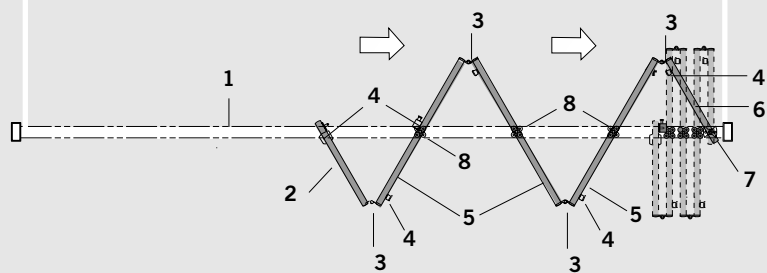

- | | |
|-----------------------|-----------------|
| 1 Track rail | 5 Folding panel |
| 2 Final folding panel | 6 Base panel |
| 3 Folding hinge | 7 Floor pivot |
| 4 Locking device | 8 Roller |

For assembly options, see pages 44/45

FSW-C system design

The FSW-C system consists of the following basic components:

- | | | |
|---|---|---|
| <ol style="list-style-type: none"> 1 installation-efficient DORMA substructure to accommodate track rail mounting requirements (optional). 2 track rail for bolting to the substructure. 3 roller, | <ol style="list-style-type: none"> 4 suspension assembly and 5 carrier profile for safe and easy sliding of the panels. 6 top door rail and 7 bottom door rail, both comprising base profiles | <p>with clip-on face and side covers.</p> <ol style="list-style-type: none"> 8 top latching bolt, 9 toughened safety glass or toughened laminated safety glass (by others), 10 bottom latching bolt. |
|---|---|---|

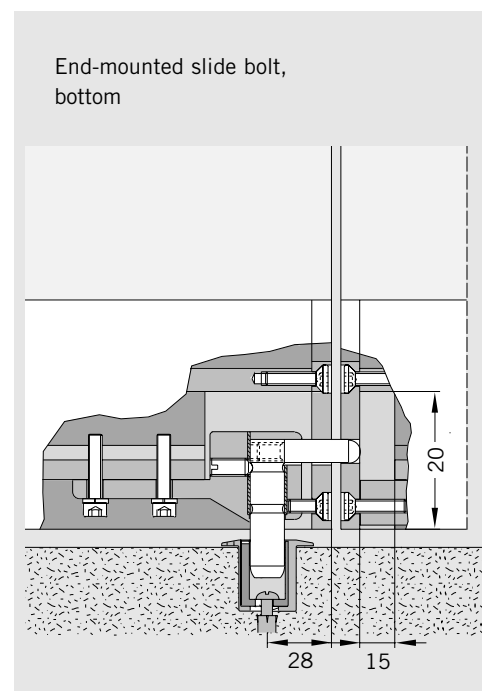
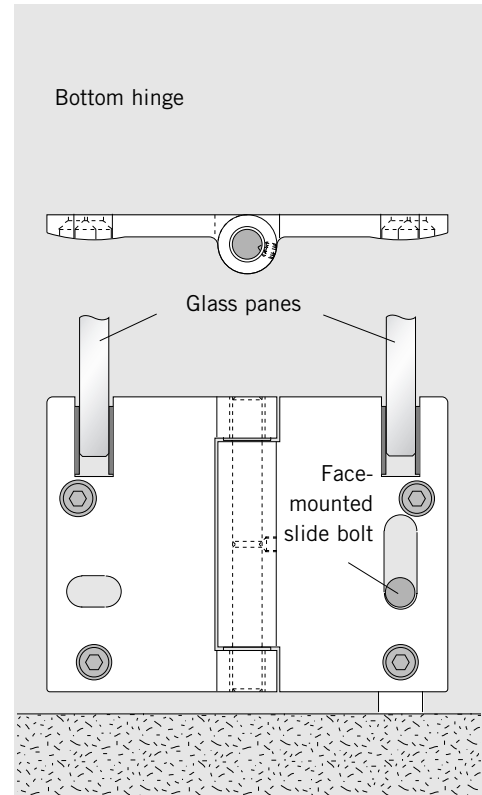
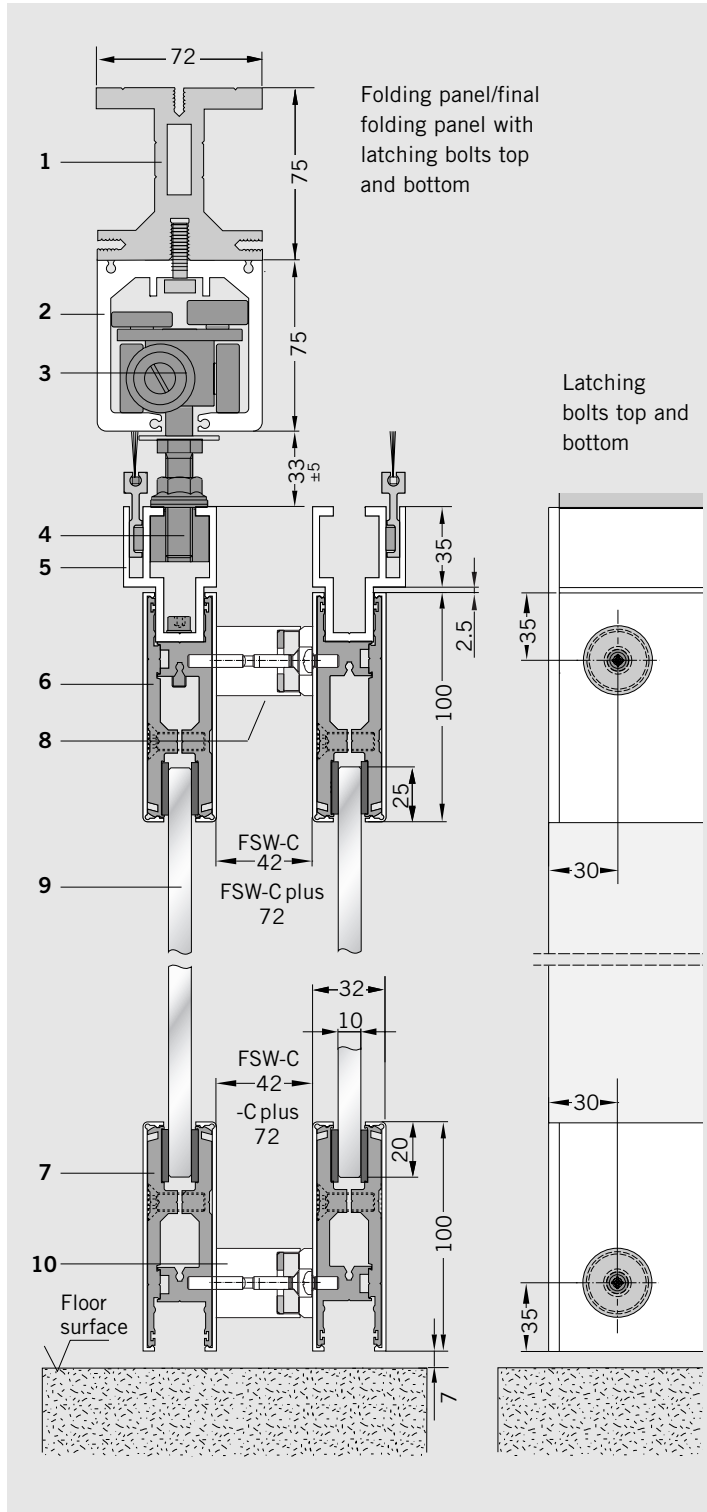

FSW-C assembly types

Type C1

- 1 single action end panel (narrow)
- 3 folding panels
- 1 base panel (narrow)

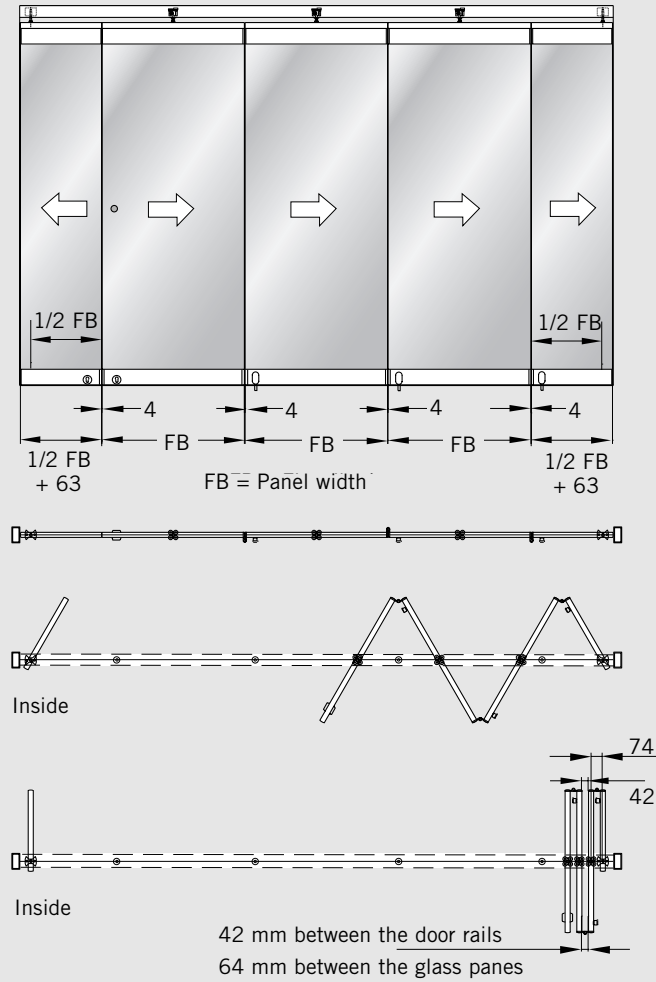

Type C2

- 1 final folding panel (narrow)
- 3 folding panels
- 1 base panel (narrow)

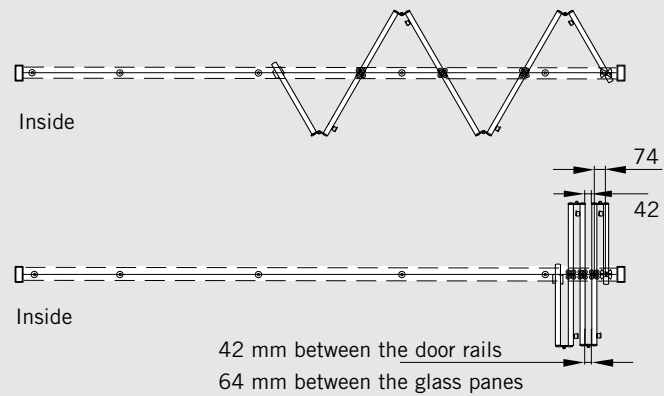

Type C3

- 1 access leaf
(final folding panel)
- 2 folding panels
- 1 base panel (narrow)

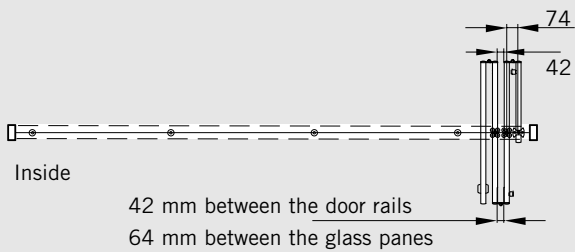
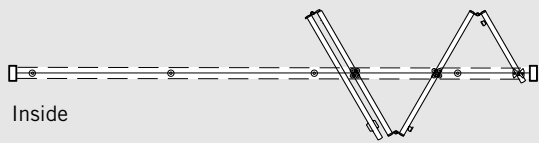
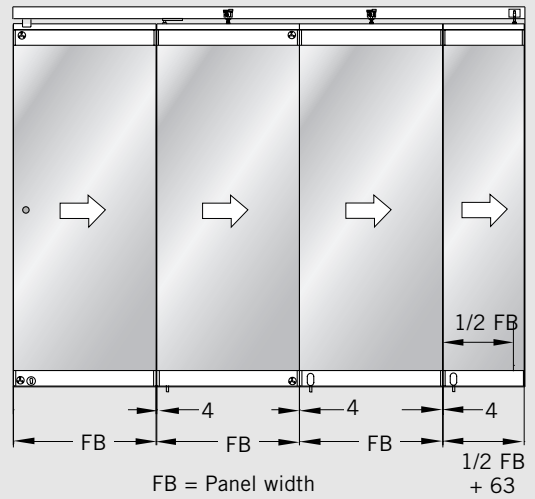

Type C3 double (counter-running) system

- Left:
- 1 base panel (narrow)
 - 2 folding panels
 - 1 access leaf (final folding panel)

- Right:
- 1 access leaf (final folding panel)
 - 2 folding panels
 - 1 base panel (narrow)

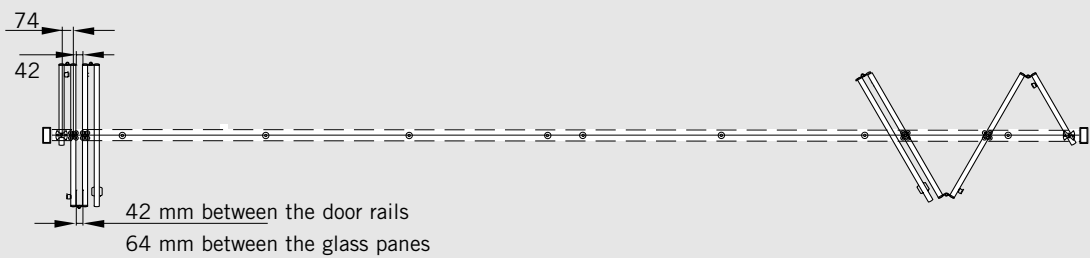
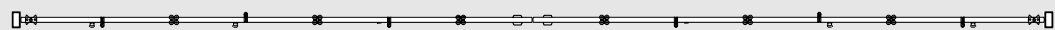

FSW-C plus

Access with convenience – the plus with the FSW-C.

The FSW-C model offers the possibility of using the final folding panel as an access door when the frontage is closed – with all the convenience offered by the DORMA TS 93 G door closer. In this case, the special bottom locking device and the top clamp-mounted stop stabilise the first folding panel, while the top angle stop ensures that the closed final folding panel is in the correct position.

The folding hinges connecting the access leaf to the folding panel have a large pivot point offset in order to create room for the door closer and pull handles. All the other folding panels are equipped with a standard folding hinge and roller.

Max. panel sizes and weights

Max. system height 3000 mm

Max. panel width 1000 mm

Width of the base panel
= half panel width + 63 mm

Max. panel weight 70 kg

Number of panels 3 to 8

Type Cp1

- 1 access leaf (final folding panel with TS 93 G door closer)
- 1 folding panel
- 1 base panel (narrow)

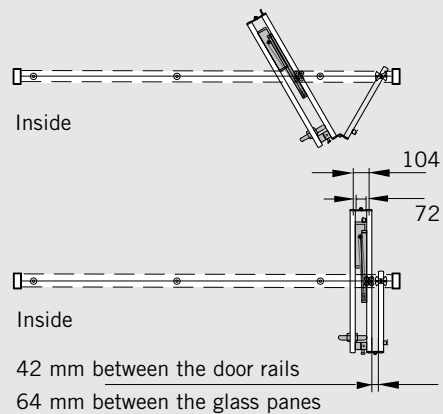
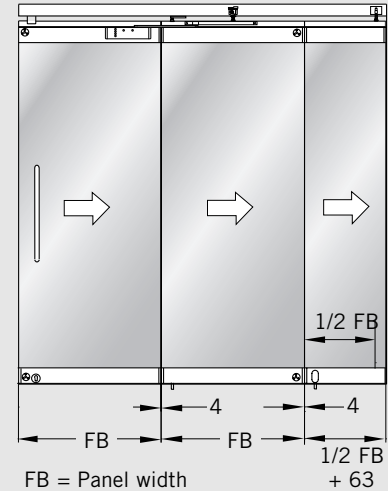

Type Cp1 double (counter-running) system

Left:

- 1 base panel (narrow)
- 1 folding panel
- 1 access leaf (final folding panel with TS 93 G door closer)

Right:

- 1 access leaf (final folding panel with TS 93 G door closer)
- 1 folding panel
- 1 base panel (narrow)

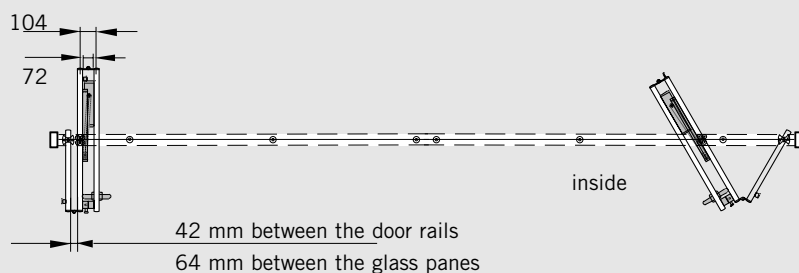
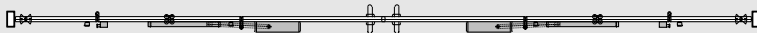

Type Cp2

- 1 access leaf (final folding panel with TS 93 G)
- 2 folding panels
- 1 base panel (narrow)



Daten and features	TS 93
Closing strength/Size	EN 2 - 5
Closing strength, variable	via adjusting screw
Closing speed, variable	via valve
Same specification for DIN-L and DIN-R	•
Latching speed adjustment	via valve
Cushioned stay limit adjustable	80° - 120°
Fixing adjustable	75° - 150°
Weight	3,5 kg
Length	275 mm
Overall depth	53 mm
Height	60 mm

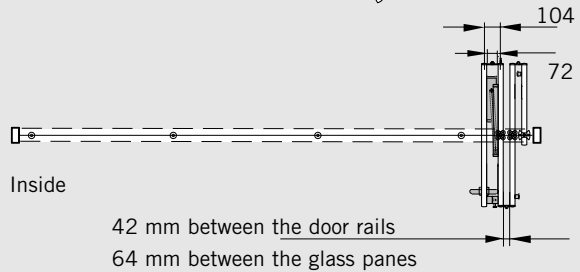
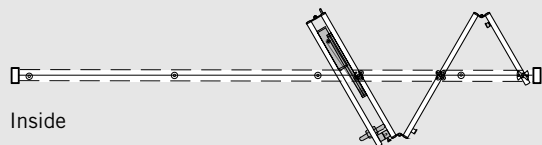
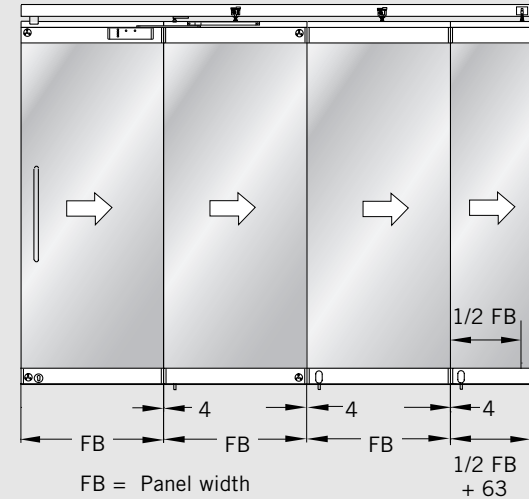

Type Cp2 double (counter-running) system

Left:

- 1 base panel (narrow)
- 2 folding panels
- 1 access leaf (final folding panel with TS 93 G)

Right:

- 1 access leaf (final folding panel with TS 93 G)
- 2 folding panels
- 1 base panel (narrow)

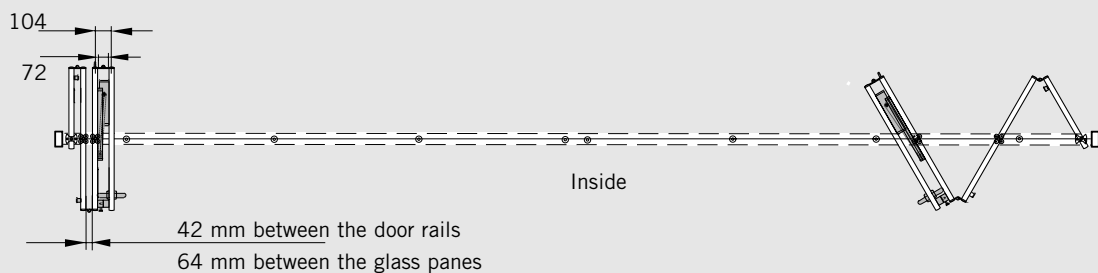
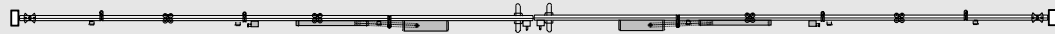

HSW-R panel types and functions

Horizontal sliding walls,
fully framed,
for toughened safety glass,
laminated safety glass or
double glazing



Robust profile frames with top, bottom and side seals for elevated resistance to mechanical loading and protection against weathering, heat loss and draughts. Available with toughened safety glass, laminated safety glass, double glazing or special glazing; standard fixing profile for 8 to 22 mm, other glazing thicknesses on application.

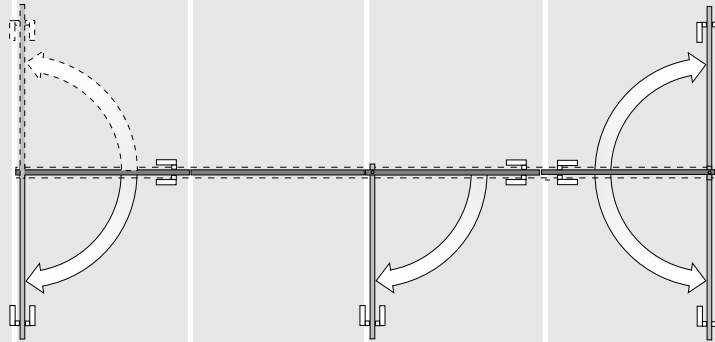
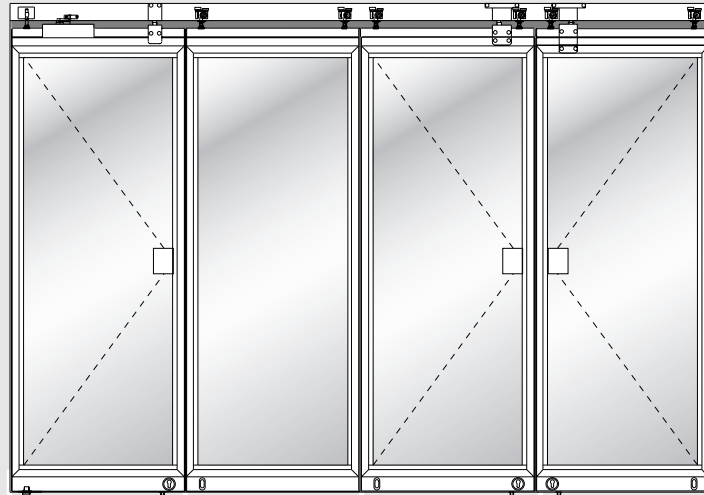

Single/double action end panel

Non-sliding.
Single action panel with floor pivot and TS 73 door closer.
Double action panel with floor pivot or BTS floor spring.

Sliding panel

Fixed when frontage closed.

Single action sliding panel

With integrated concealed door closer type ITS 96, Size 3-6; operational when frontage closed. Minimal panel width 870 mm.

Double action sliding panel *

With integrated concealed door closer type ITS 96, Size 3-6; operational when frontage closed. Minimal panel width 870 mm.

Max. panel sizes and weights

Max. system height	3000 mm	3000 mm	3000 mm	3000 mm
Max. panel width	1100 mm	1100 mm	1100 mm	1100 mm
Max. panel weight	100 kg	100 kg	100 kg	100 kg

The individual panels can also be of differing widths.
The largest width should not exceed max. 115% of the smallest width.

* For these panel types please consider our notes on portal systems on page 89.

HSW-R system design

Irrespective of the function of the individual panels, an HSW-R system comprises the following components:

- 1 Installation-efficient DORMA substructure to accommodate track rail mounting requirements (optional)
- 2 Track rail for bolting to the substructure
- 3 Carrier
- 4 Suspension assembly
- 5 Adapter frame
- 6 Glazing frame profile, horizontal
- 7 Glazing rail
- 8 Glazing frame profile, vertical
- 9 Toughened safety glass, laminated safety glass or sealed double glazing units (by others)
- 10 Bottom rail

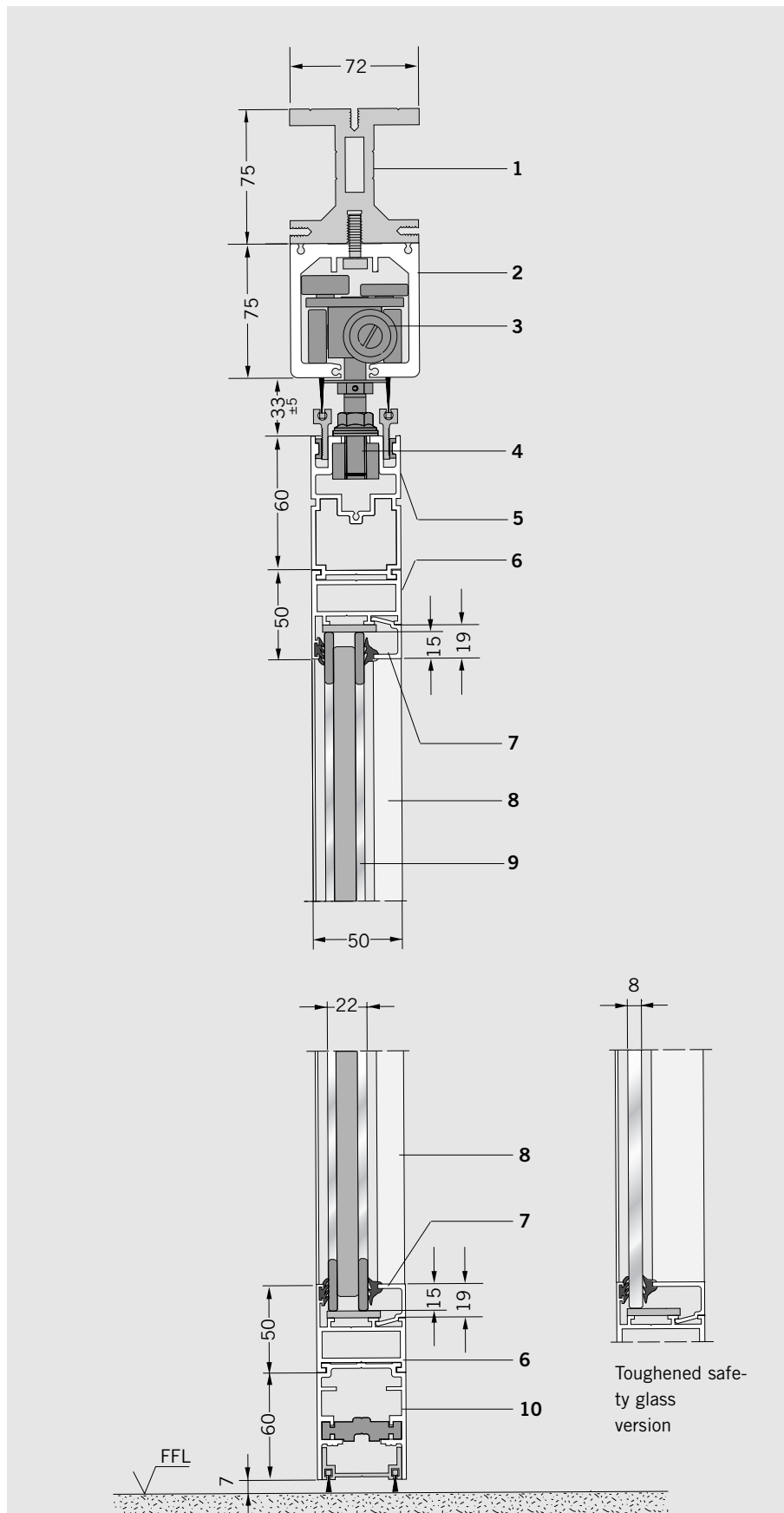

End panel

Non-moving and always equipped with bottom deadbolt with the option of a top bolt or side action dead-lock. Single action or double action options.

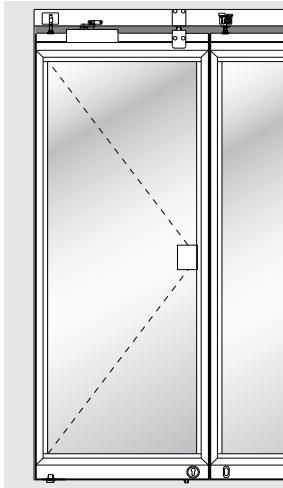

Double action end panel

Assembly types:

- Floor pivot with round spindle
- BTS 84 for panels up to 100 kg, with optional hold-open at 90° door opening angle
- BTS 80 for panels of 100-150 kg, provided with hold-open as standard

Single action end panel

with stop plates at the top bolt.

Assembly types:

- Floor pivot with round spindle
- As above, but with DORMA TS 73 or TS 92 overhead door closer
- BTS 84 for panels up to 100 kg, with optional hold-open at 90° door opening angle
- BTS 80 for panels of 100-150 kg, provided with hold-open as standard

Single action or double action end panel with floor pivot

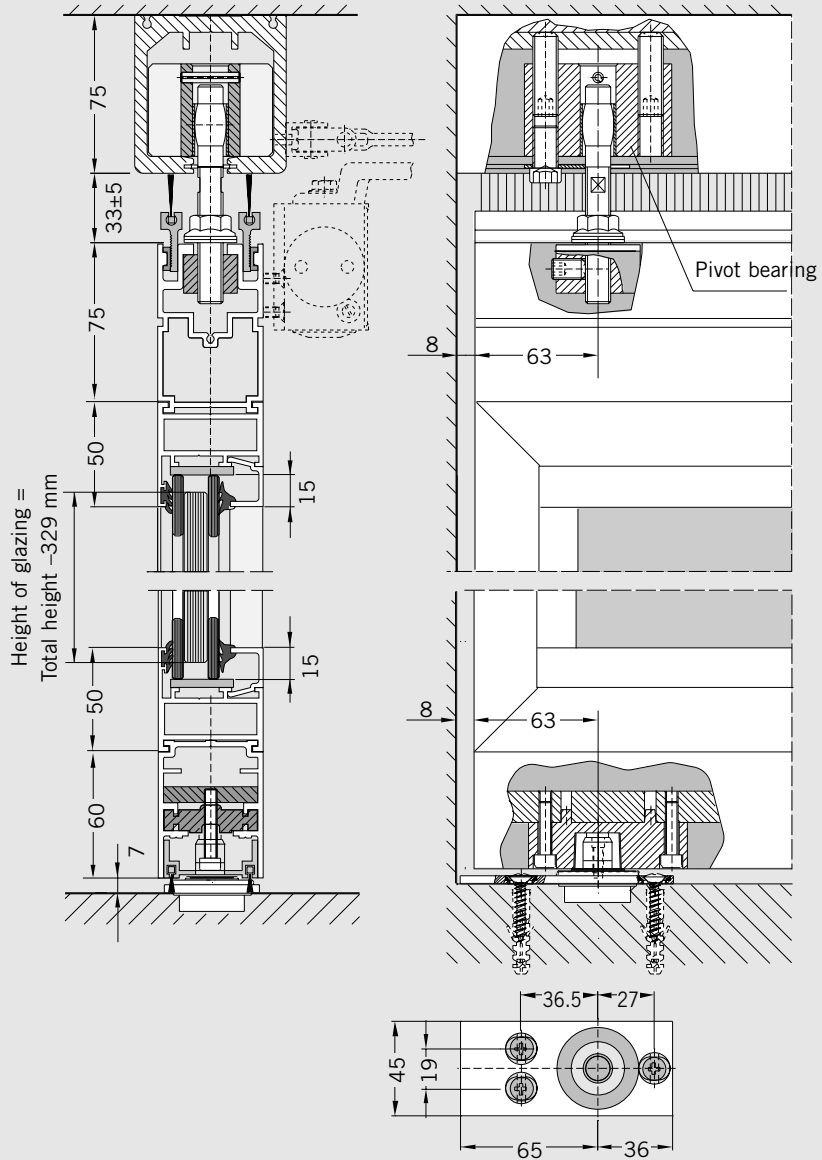

Double action end panel with floor spring

Mounting dimensions

	BTS 80	BTS 84
a	78	108
b	60	40
c	341	306
d	51-57	51-58

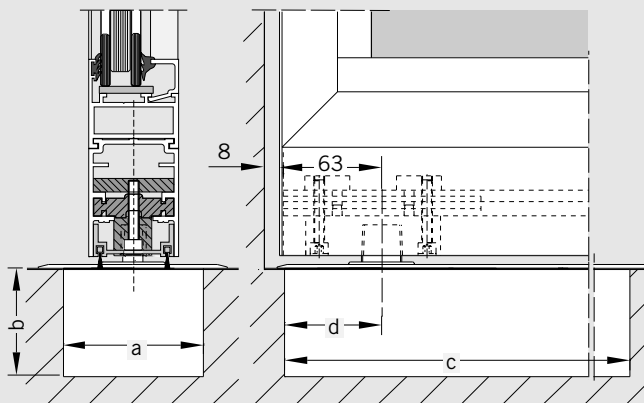

Single action end panel with TS 73 overhead door closer and additional locking device and door stop

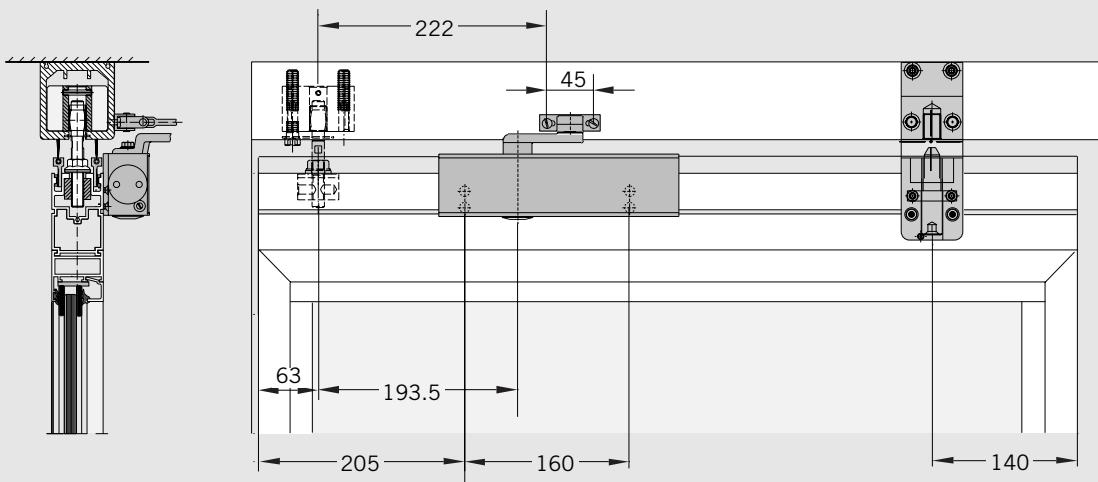

Single action end panel with TS 92 overhead door closer and additional locking device

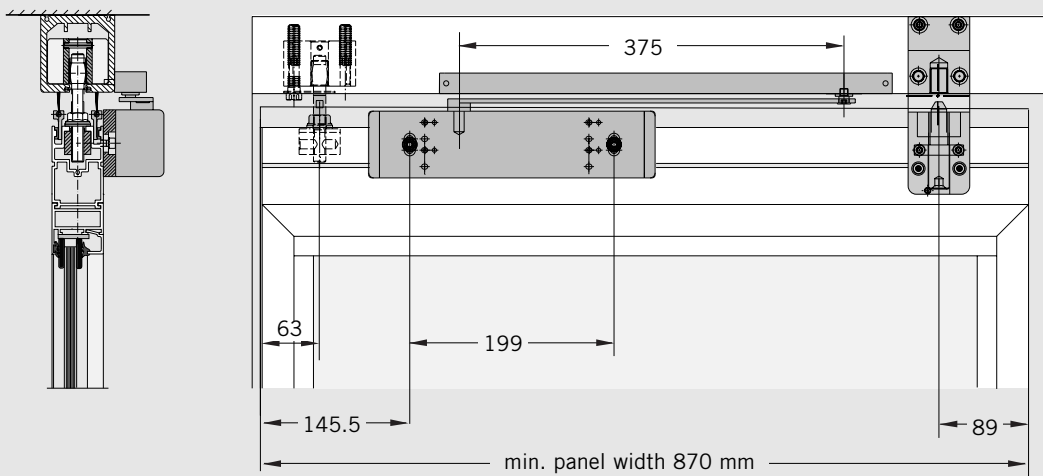

Data and features	TS 73 V	TS 92
Closing strength/size	EN 2-4	EN 2-4
Closing strength, variable	via adjusting screw and arm hinge	via adjusting screw and arm hinge
Closing speed adjustment	via valve	via valve
Non-handed	•	•
Latching speed adjustment	via arm	via arm
Cushioned stay limit adjustment	75°-180°	80°-120°
Hold-open adjustment	75°-160°	75°-150°
Weight	1.8 kg	1.9 kg
Length	233 mm	281 mm
Overall depth	42.50 mm	47 mm
Height	60 mm	65 mm

Additional locking device

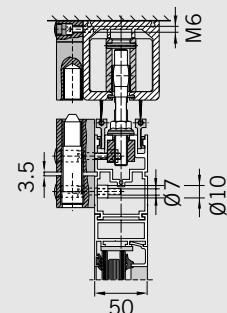

Sliding panel

Fixed when partition is closed.

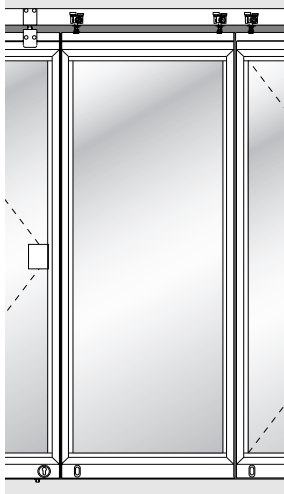

Sliding panels

The sliding panels are moving elements. Once in their closed position, they are locked down.

The components available for this are provided in the bottom rail in the form of face-mounted floor bolts or deadlocks.

Sliding panel

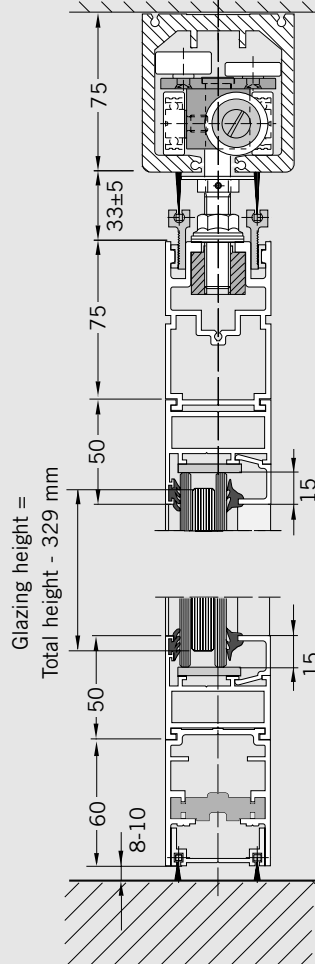

Engaging the panel in the strike plate

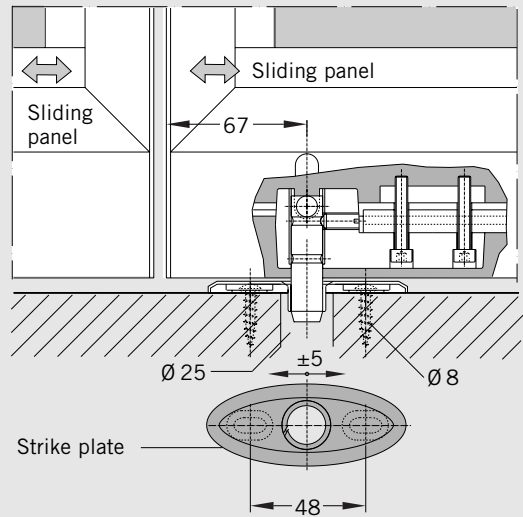

Engaging the panel in eccentric bushing

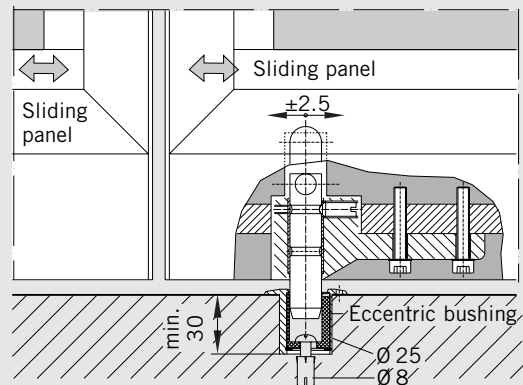

Sliding panel to panel connections

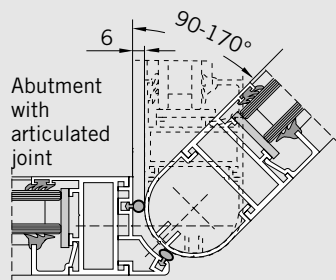
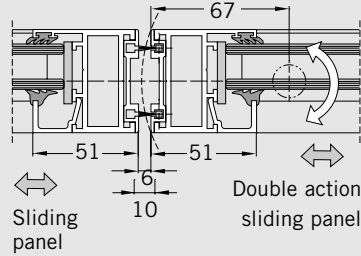
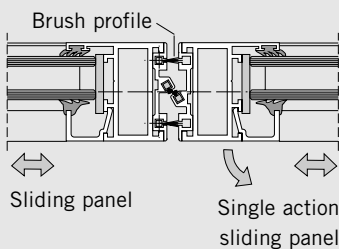
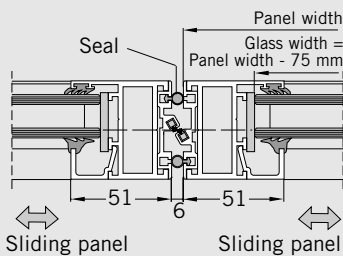

Panel to wall connection

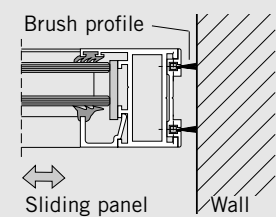
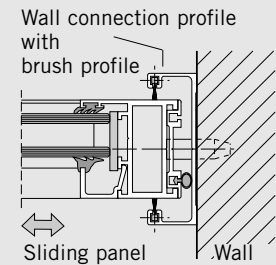

Single action sliding panel

Single action sliding panel with integrated ITS 96, size 3-6 concealed door closer for operation as single action door when the frontage is closed.

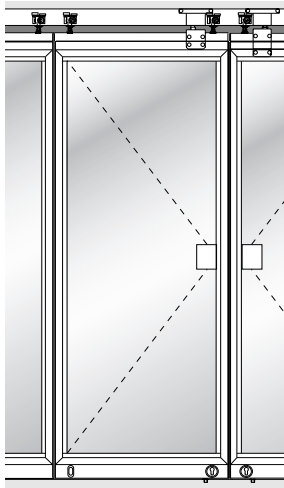

Single action sliding panel with integrated DORMA ITS 96 concealed door closer, size 3-6

This panel type is used where passdoors only need to be opened in one direction. The single action sliding panel can be configured for either inward or outward opening.

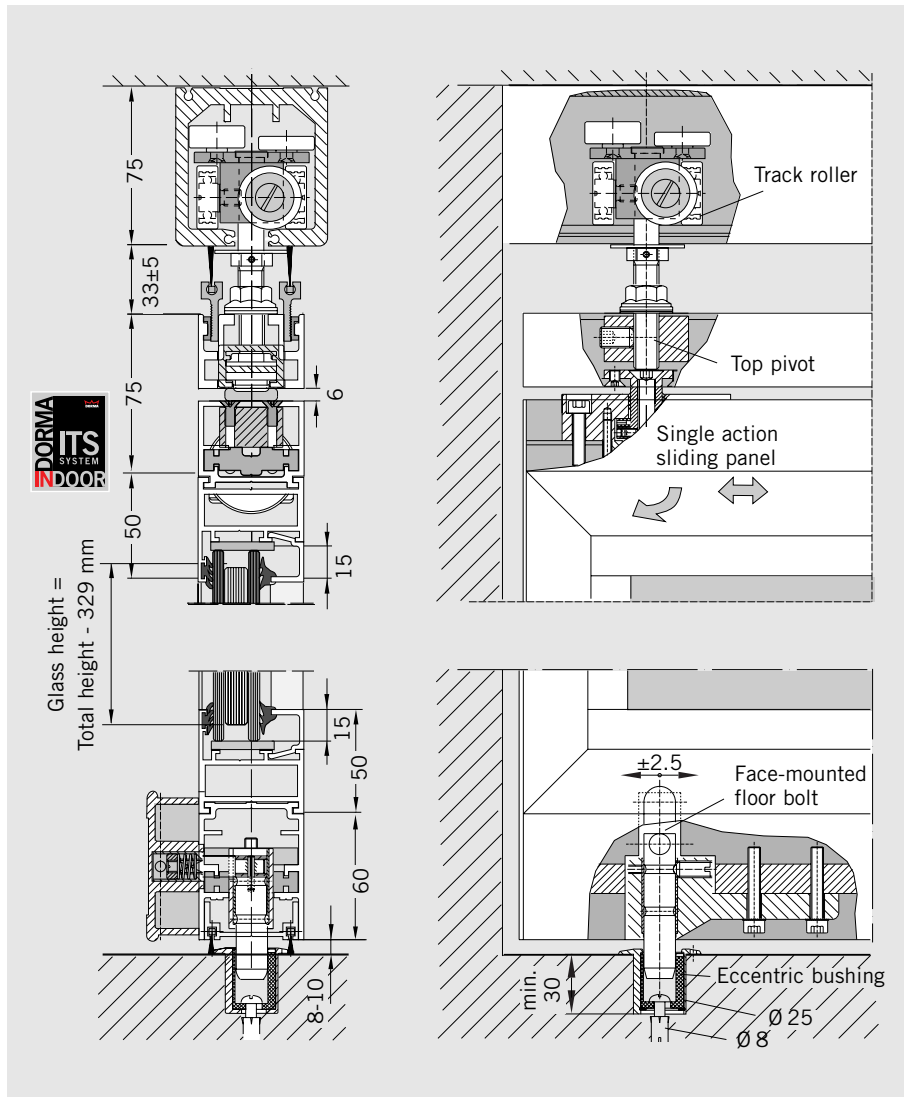

Standard assembly

- top: Pivot bearing, ITS 96, size 3-6, one locking device
- bottom: Face-mounted floor bolt as pivot (released for sliding function)

Optional equipment

- top: Second locking device (for reshuffle bypass stacking)
- bottom: Optional second face-mounted floor bolt or deadlock

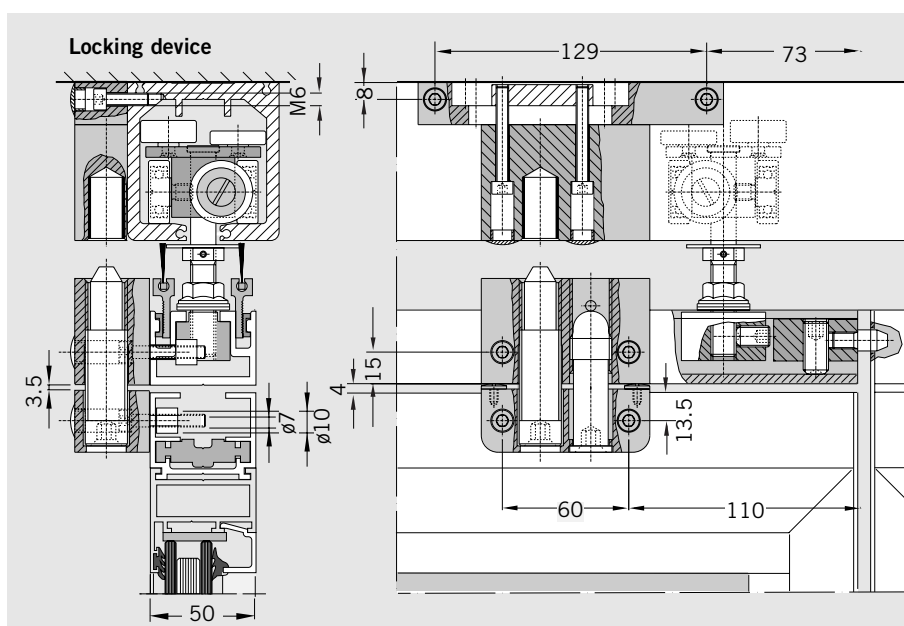

Double action sliding panel

With integrated ITS 96, size 3-6 concealed door closer, for operation as double action passdoor when the frontage is closed.

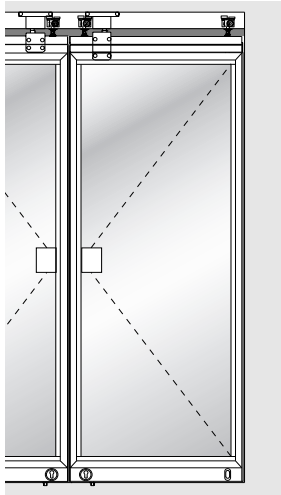

Double action sliding panel with integrated DORMA ITS 96 concealed door closer, size 3-6

Double action sliding panels with DORMA ITS 96, size 3-6 door closers are characterised by their exceptional ease of installation and operation. These passdoor panels are generally equipped with a bottom deadlock and top locking device plus a bottom floor bolt operating as the pivot bearing (released for the sliding function). The ITS 96 does not feature a hold-open function as standard.

For these panel types please consider our notes on portal systems on page 89.

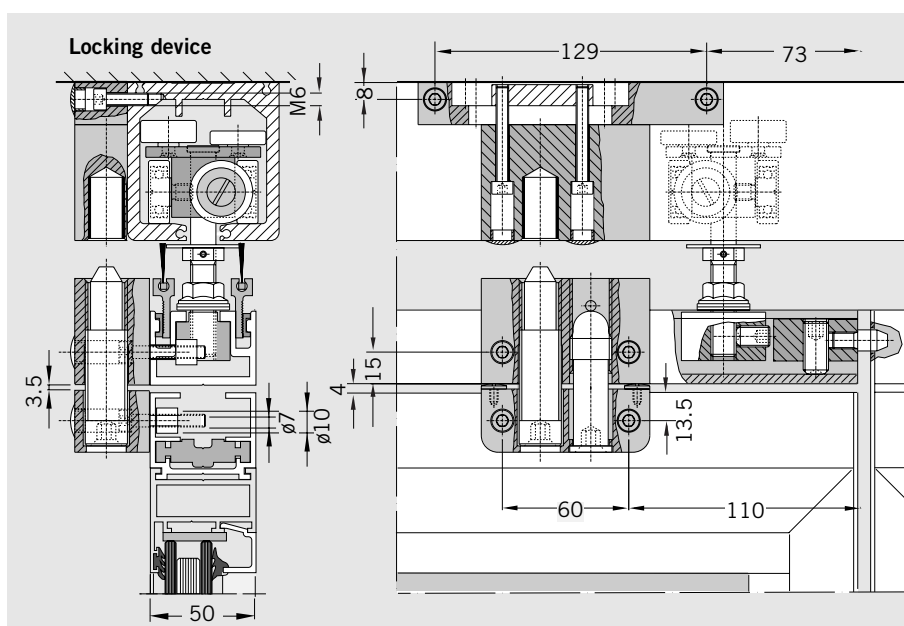
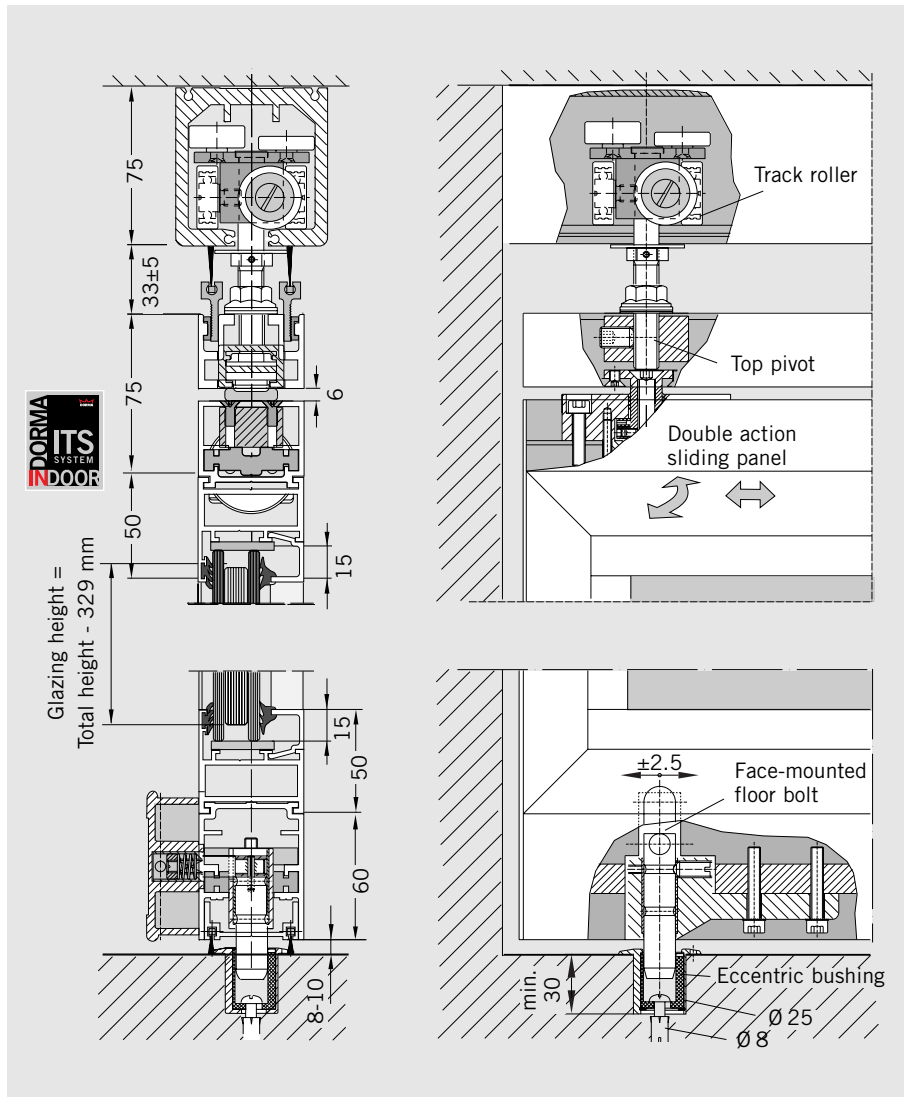

HSW-ISO panel types and functions

Double glazing with thermal-break frame profiles.



Panel types

These double-glazed panels with their frames of thermal-break profiles (frame material group 2.1) offer outstanding protection against the influences of the weather, effective thermal insulation and comfortable temperatures - even close to the frontage surface - during seasonal changes and in the winter months. And all these effects are ideally enhanced by laterally arranged, interlocking multiple-lip seals plus automatically extending top and bottom rubber seals that are pressed against the track rail and floor when the frontage is closed. Glass thickness 8-49 mm.

Max. panel sizes and weights

Max. system height	3000 mm	3000 mm	3000 mm	3000 mm
Max. panel width	1100 mm	1100 mm	1100 mm	1100 mm
Max. panel weight	120 kg	120 kg	120 kg	120 kg

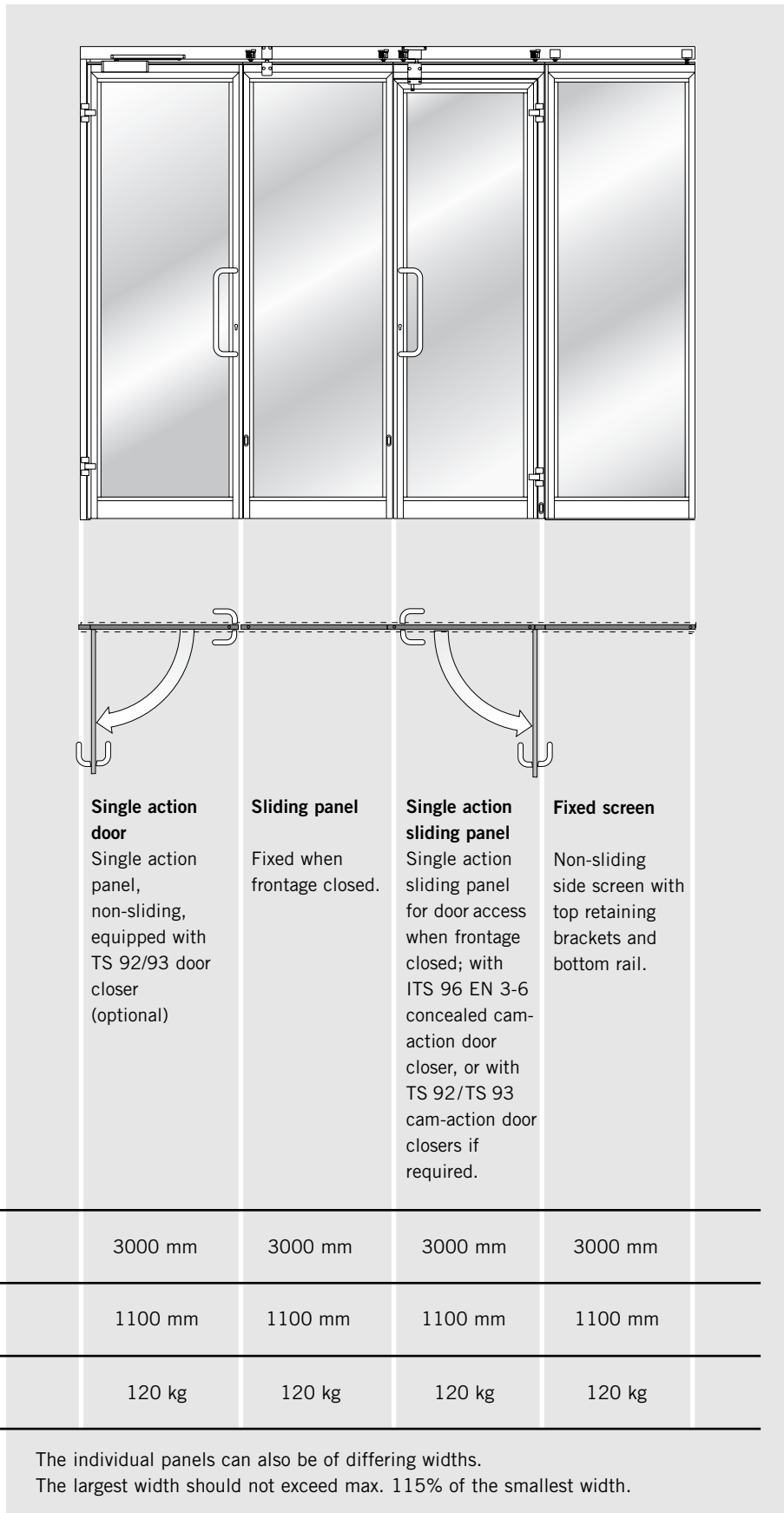

HSW-ISO system design

Irrespective of the function of the individual panels, an HSW-ISO system comprises the following basic components:

- 1 Installation-efficient DORMA substructure to accommodate track rail mounting requirements (optional)
- 2 Track rail for bolting to the substructure.
- 3 Carrier
- 4 Suspension assembly and bearing profile for safe and easy sliding of the panels
- 5 Glazing rail
- 6 Sealed double glazing unit (by others)
Glass thickness 8-49 mm
- 7 Automatically extending rubber seal
- 8 Insulating strips in the thermal-break profile
- 9 Bottom frame profile

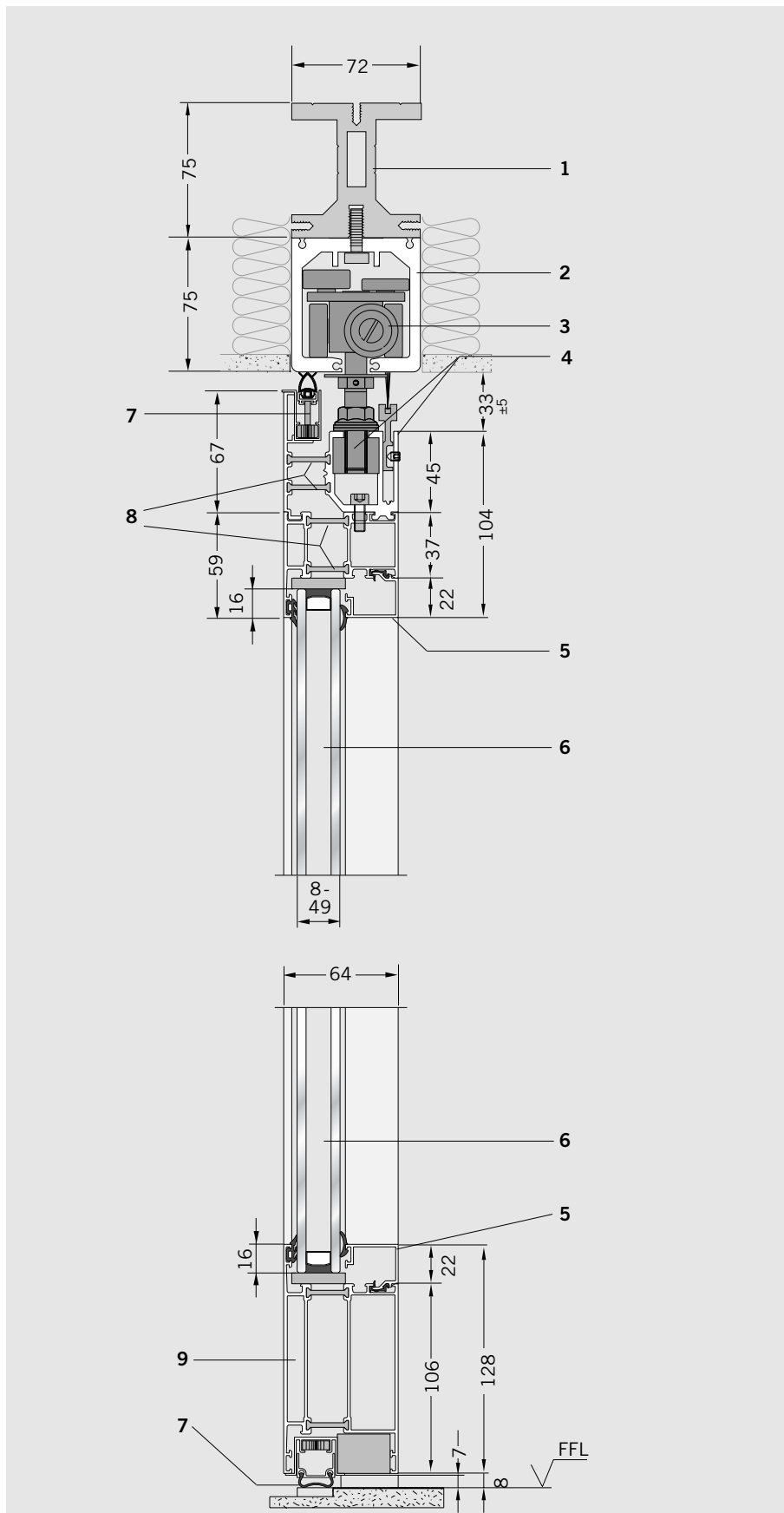

Single action door with wall connection profile

Single action panel, non-sliding, operates independently of the rest of the system.

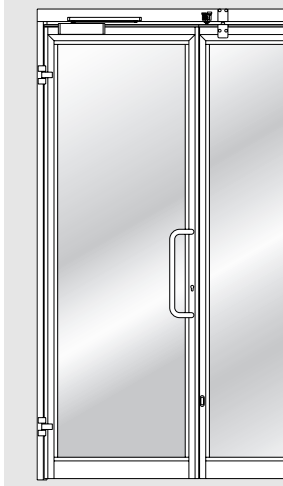

The single action door with wall connection arm assembly can be swung round 170°, so leaving the entire operating zone free. The closed panel is secured by a mortise centre lock.

Single action door with wall connection

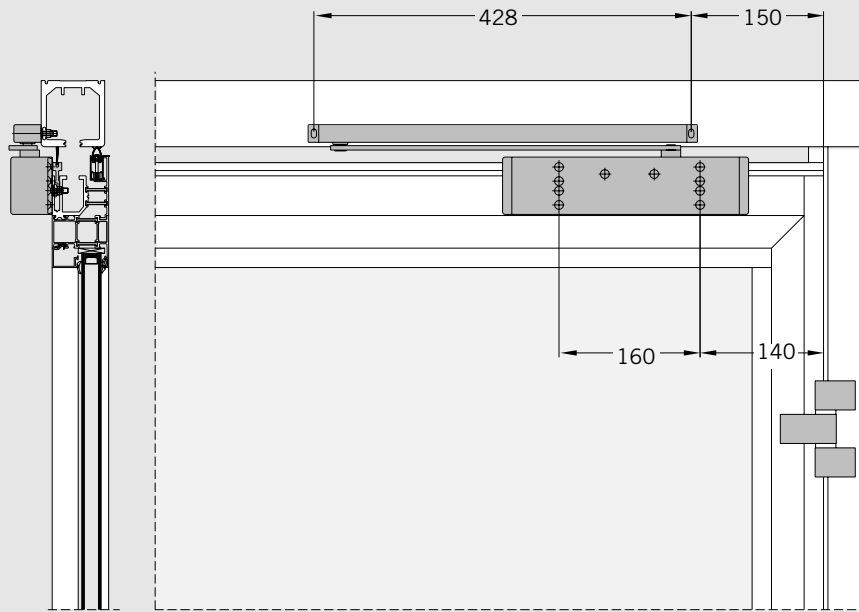

Single action door with wall connection

Inward opening

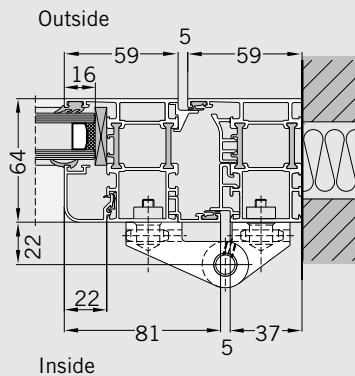

Outward opening

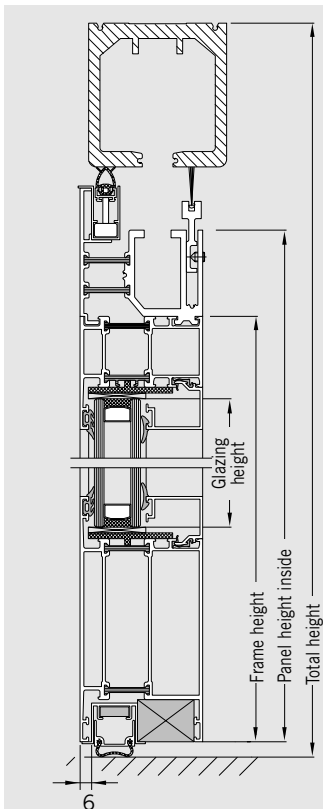
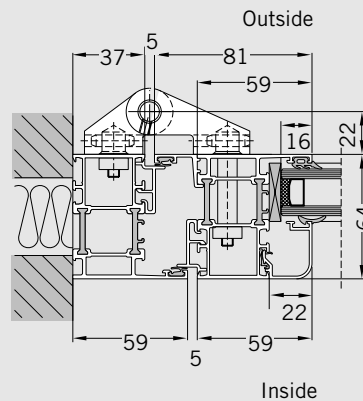

In order to provisionally determine the glazing area per panel, please apply the following formula:

$$\text{Approx. glazing area per panel} = \text{Panel width} \times \text{total height} \times 0.78$$

The precise dimensions of the sealed double glazing units to be ordered should be exclusively taken from the approval drawing released by DORMA-Glas.

Fixed screen

Non-sliding side screen that decouples from the rest of the system.

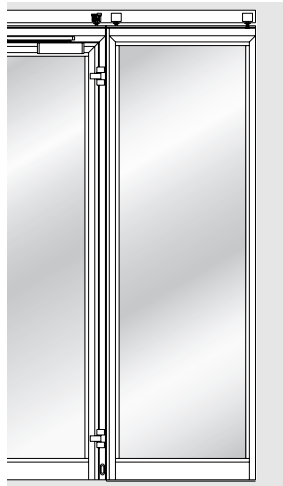

The fixed screen has the same appearance as the sliding panels. Instead of the automatically extending bottom rubber seal, it features a bottom rail.

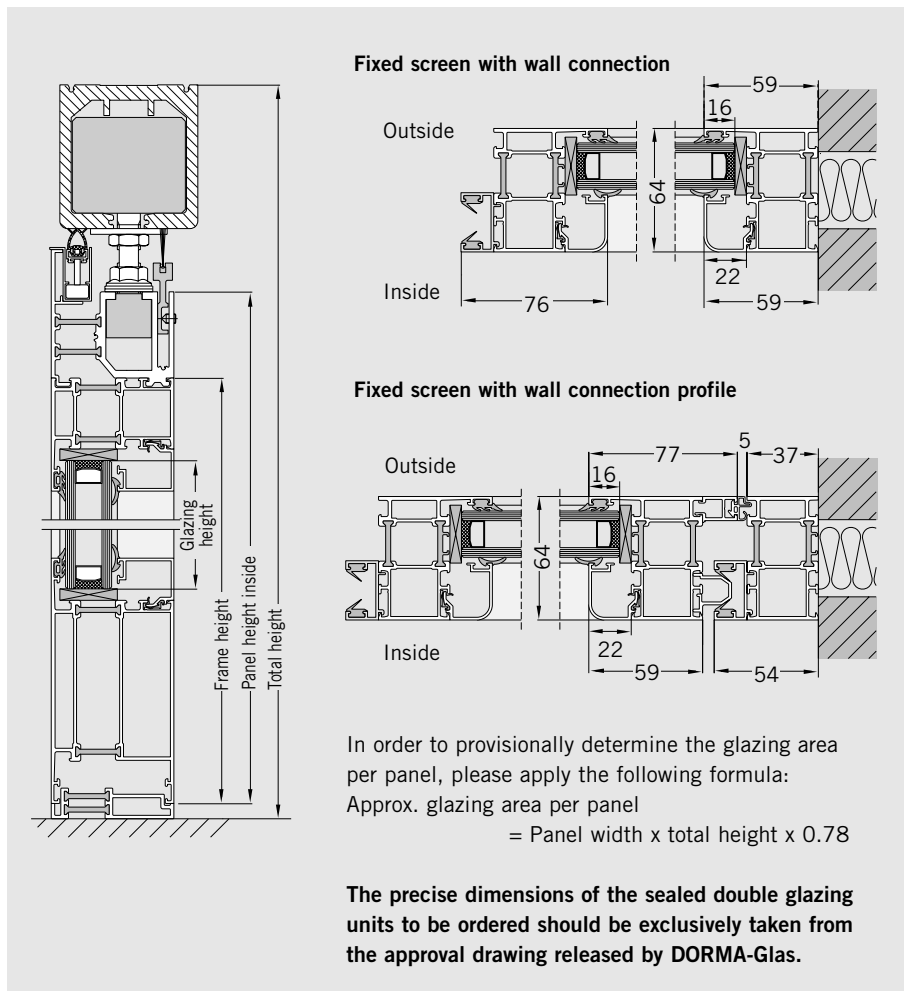

Thermal and sound insulation Table (extract) for determining the k-value of various types of glazing installed in conjunction with frame material group 2.1. Measurements performed by the Institut für Fenstertechnik e.V. (Inst. of Window Technology) of Rosenheim, Germany using an installed 4-panel system revealed a sound reduction level of min. 27 dB.	Double glazing with ...mm air gap	Glazing k_v	Windows and french doors including frame k_f
	> 6 to < 8	3.4 W/m ² K	3.2 W/m ² K
	> 6 to < 10	3.2 W/m ² K	3.0 W/m ² K
	> 10 to < 16	3.0 W/m ² K	2.9 W/m ² K
	2 x > 6 to < 8	2.4 W/m ² K	2.5 W/m ² K
	2 x > 8 to < 10	2.2 W/m ² K	2.3 W/m ² K

Date and features	TS 92		TS 93	
	Closing strength/size	EN 2-4	EN 2-5	EN 5-7
Closing force, variable	via adjusting screw	via adjusting screw	via adjusting screw	
Closing speed adjustment	via valve	via valve	via valve	
Non-handed	yes	yes	yes	
Latching speed adjustment	via valve	via valve	via valve	
Cushioned stay limit adjustment	80°-120°	80°-120°	80°-120°	
Hold-open adjustment	75°-150°	75°-150°	75°-150°	
Weight	1.9 kg	3.5 kg	5.2 kg	
Length	281 mm	275 mm	285 mm	
Overall depth	47 mm	53 mm	62 mm	
Height	65 mm	60 mm	71 mm	

Sliding panel

Fixed when the frontage or partition is closed.

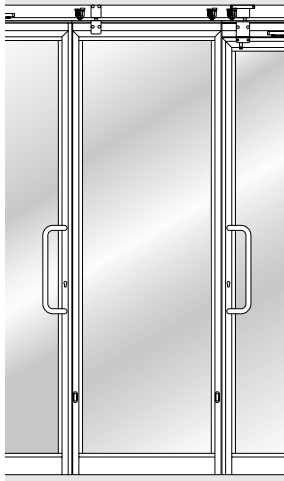

Sliding panels

The sliding panels are the moving elements. Once in their closed position, they are locked down. Face-mounted floor bolts are available as an option for the bottom glazing rail.

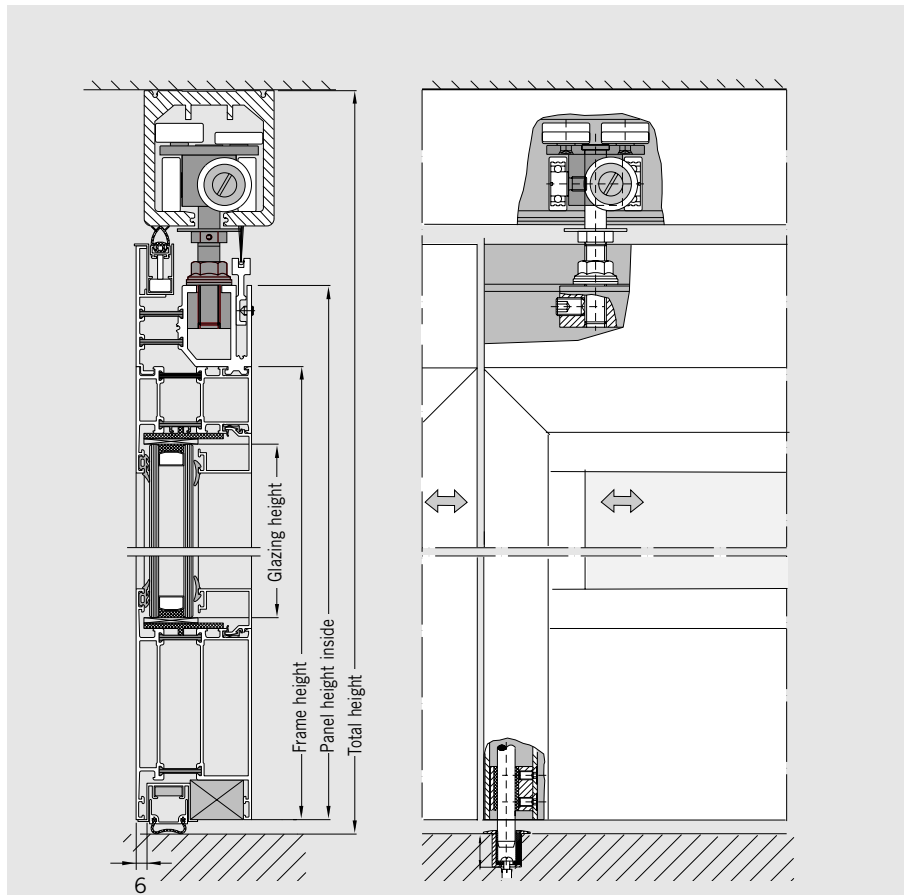

In order to provisionally determine the glazing area per panel, please apply the following formula:

Approx. glazing area per panel = Panel width x total height x 0.78

The precise dimensions of the sealed double glazing units to be ordered should be exclusively taken from the approval drawing released by DORMA-Glas.

Horizontal sections of the sliding panels with connection details

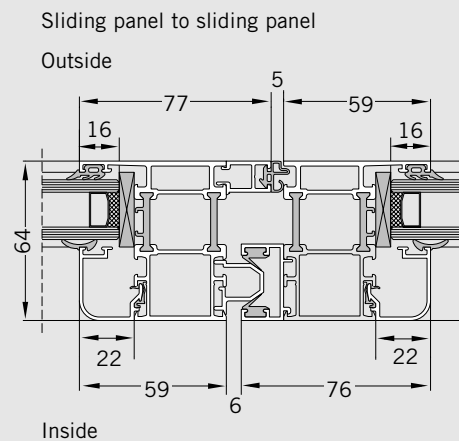
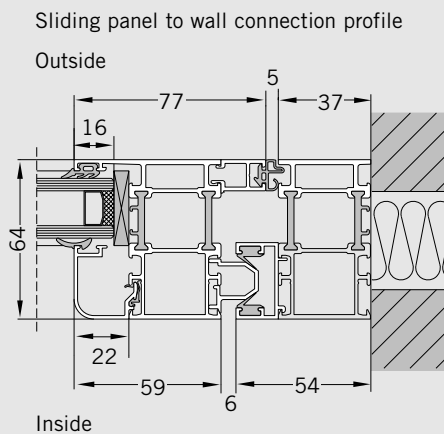

Single action sliding panel with DORMA ITS 96, size 3-6 cam-action door closer

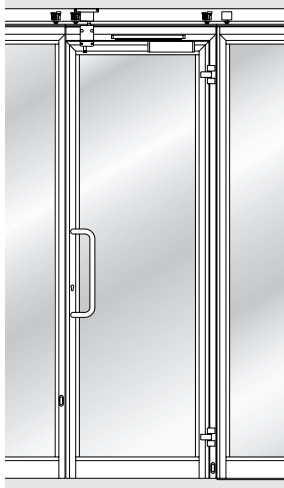

This panel type is installed where doors need to be opened in one direction. The cam-action door closer can be fitted so that the single action panel is either inward or outward opening.

Standard assembly

- top: Pivot bearing, ITS 96, size 3-6 one locking device
- bottom: Face-mounted slide bolt as pivot (released for sliding function)

Optional equipment

- top: Second locking device (for reshuffle bypass stacking)
- bottom: Optional second face-mounted slide bolt

Single action sliding panel with integrated ITS 96

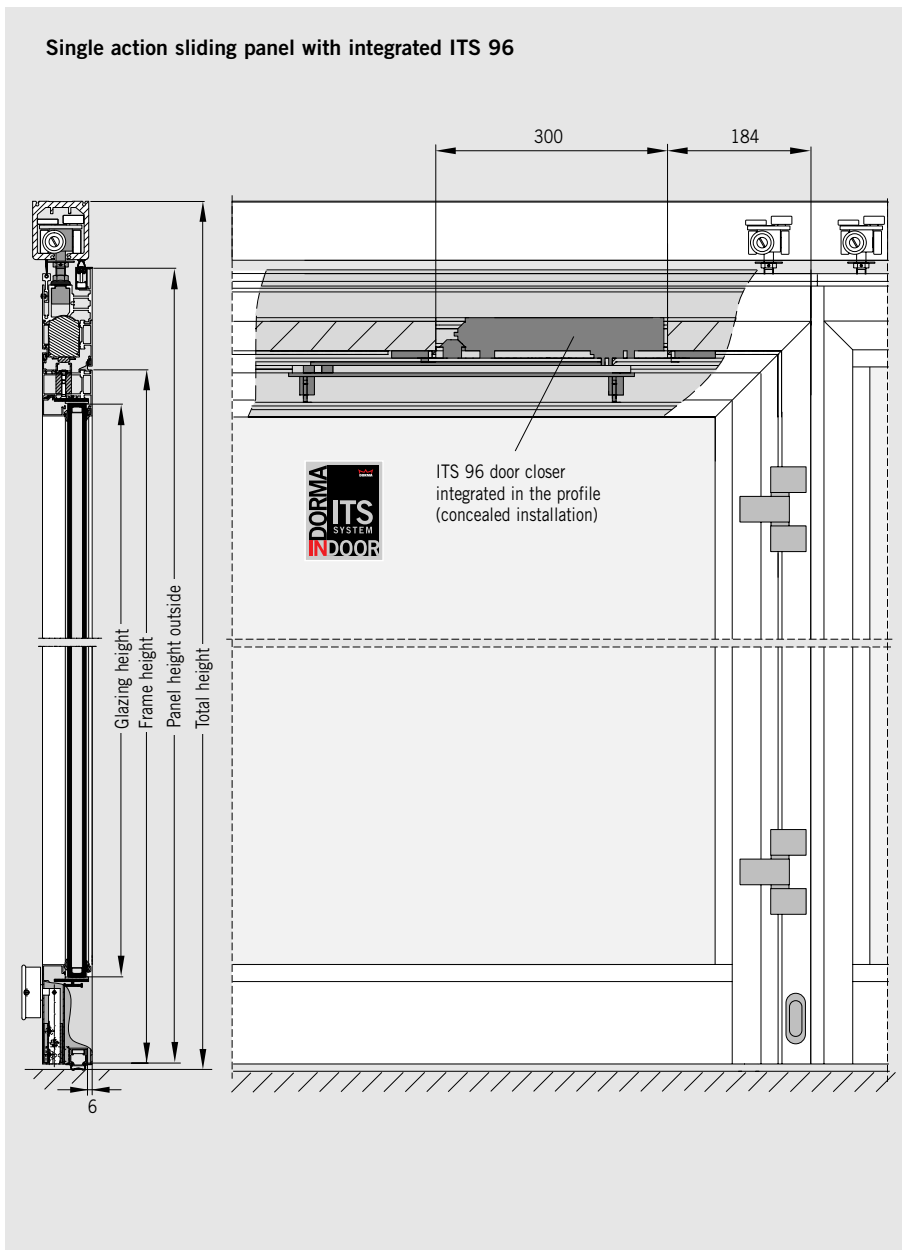

Horizontal section of single action panels, inward or outward opening

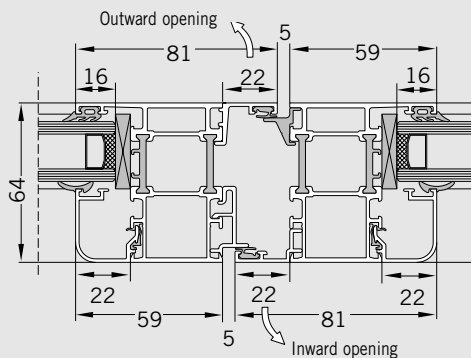

Function of the top locking device

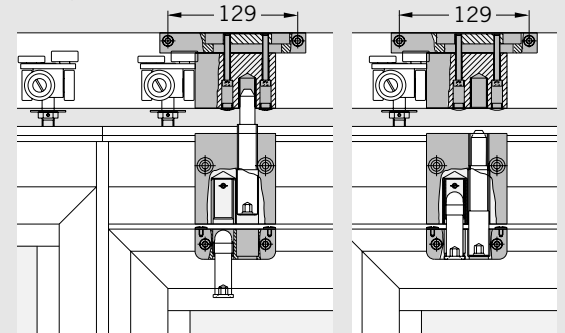

**Stacking in the reshuffle
bypass configuration**

This special stacking arrangement is applied when the panels should be parked in a niche and no single action end panel should be visible in the frontage.

Please also see the following illustrations.

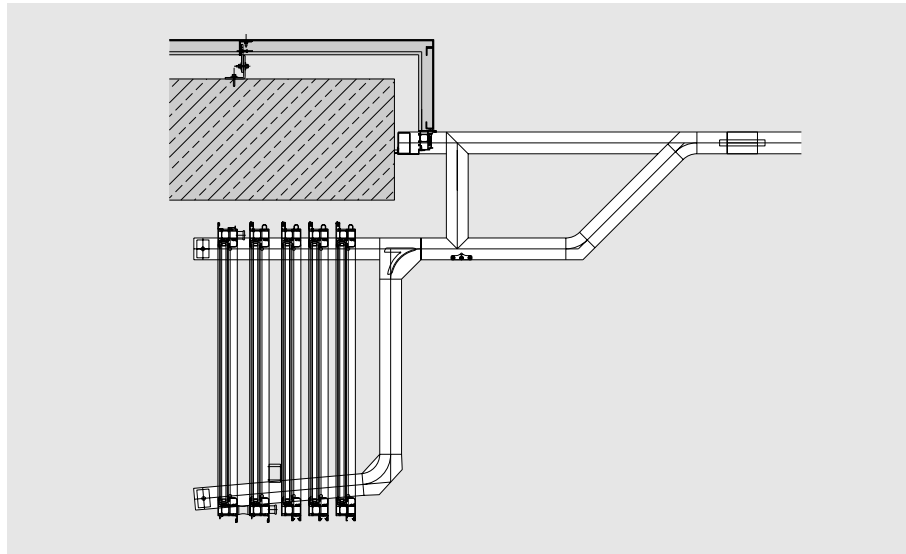

Sliding panel in bypass travel mode (sliding end panel)

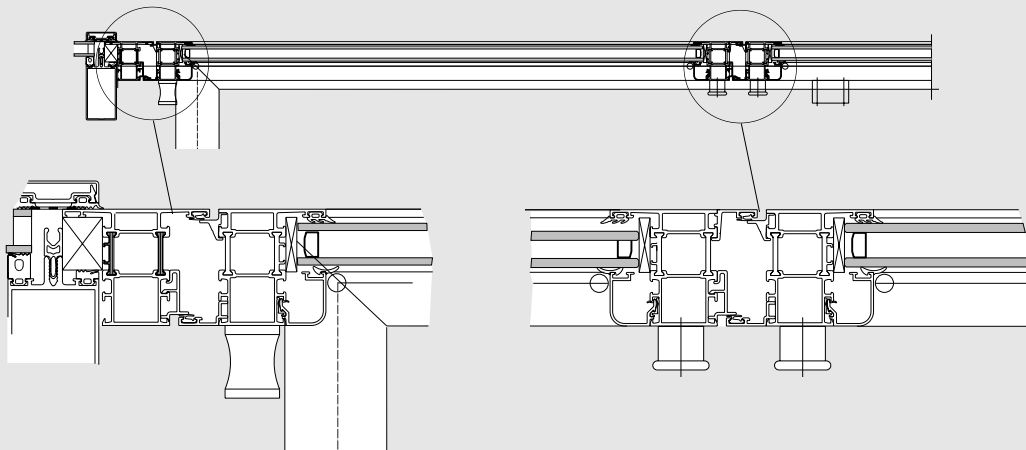

Single action sliding panel in bypass travel mode (outward opening only)

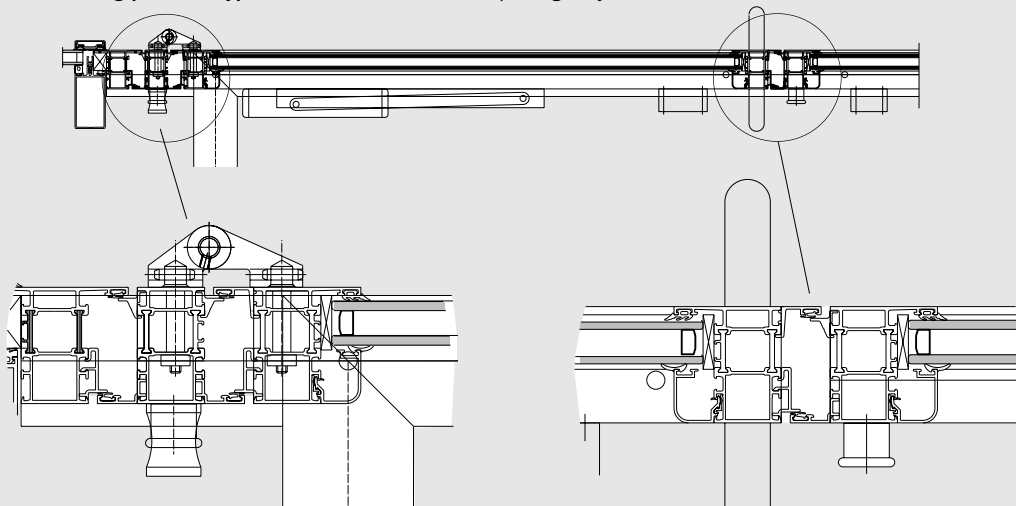

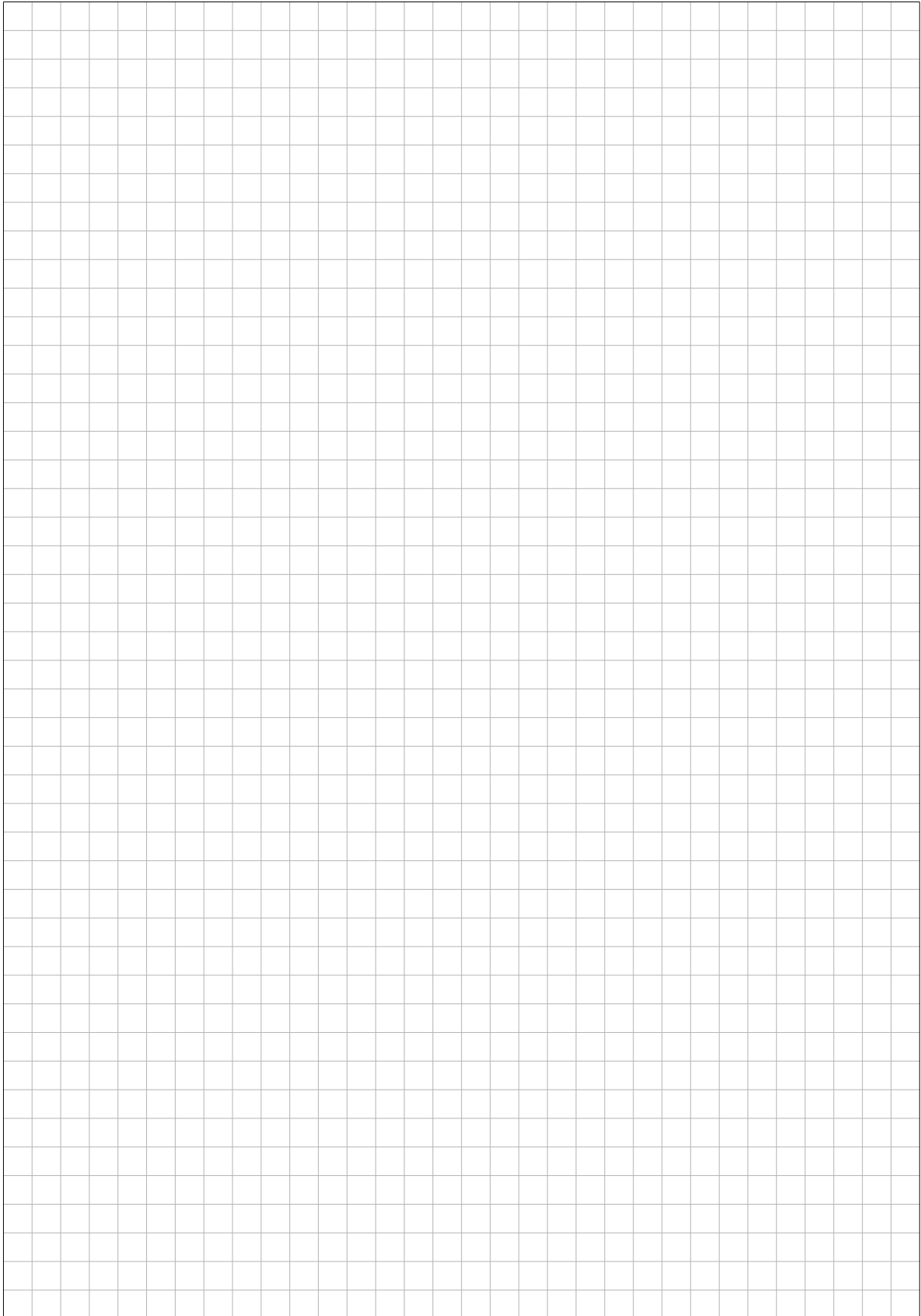
A large, empty grid of small squares, intended for taking notes or drawing. The grid consists of approximately 30 columns and 40 rows of squares.

Seals retrofittable

The following retrofittable profiles are available to provide the necessary lateral sealing so that the horizontal sliding can be made draught-proof for winter operation.

Aluminium alloy profile with brush

for 10 mm glass

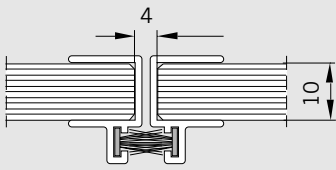

for 12 mm glass

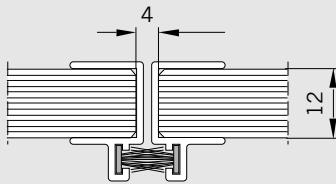

Clear plastics profile (not for single/double action end panels or double action sliding panels)

for 10 mm glass

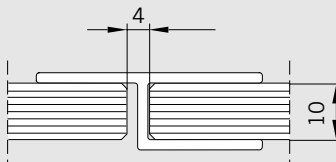

for 12 mm glass

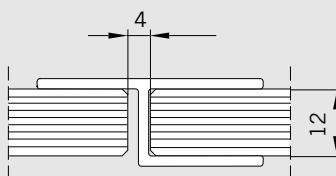

Seals individually customised

These frame profiles for rendering doors draught-proof are individually manufactured and therefore need to be taken into account when designing the horizontal wall system. All the relevant specifications must be provided with the system order.

Fineline with brush seal (pages 75-80)

for 10 mm
and 12 mm glass

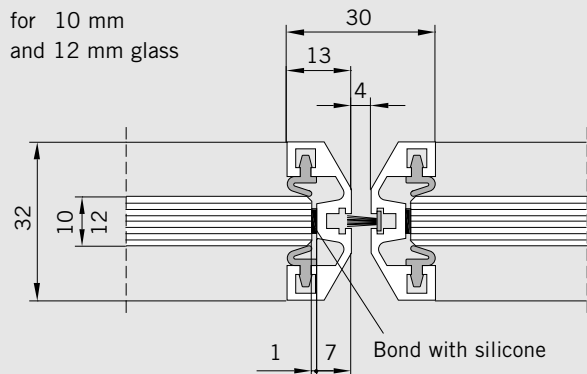

Line Single action door with brush seal (page 81)

for 10, 12 and
13.5 mm glass

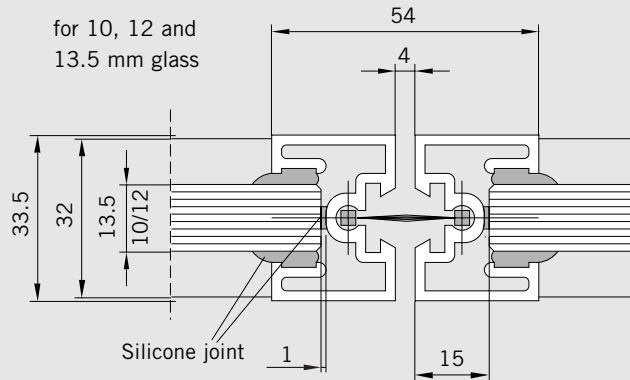

Line Sliding door with rubber seal (pages 82-84)

for 10, 12 and
13.5 mm glass

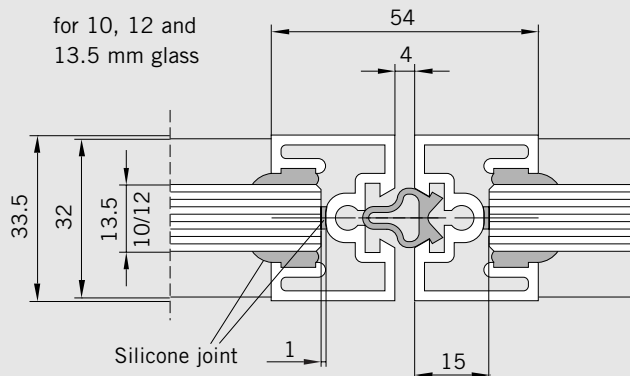

Fineline Seal

End panel

Non-moving and always equipped with a bottom deadbolt with the option of an additional top bolt or side-action deadlock. Can be designed as a single action or double action door.

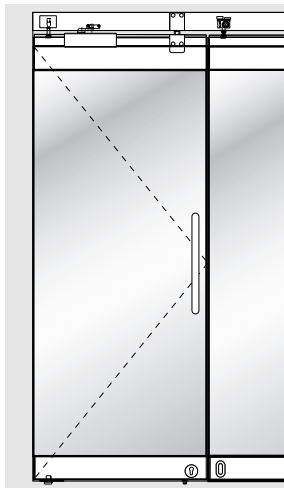

Calculation of the glass width
= Panel width – 16 mm

As-delivered condition:

Cut lengths supplied from factory
= Partition height – 100 mm
Holes and recesses are pre-machined in the profile for the bottom glazing rail only.

Any further machining work required for connection to the top glazing rail has to be performed on site.

Single action or double action end panel with floor pivot

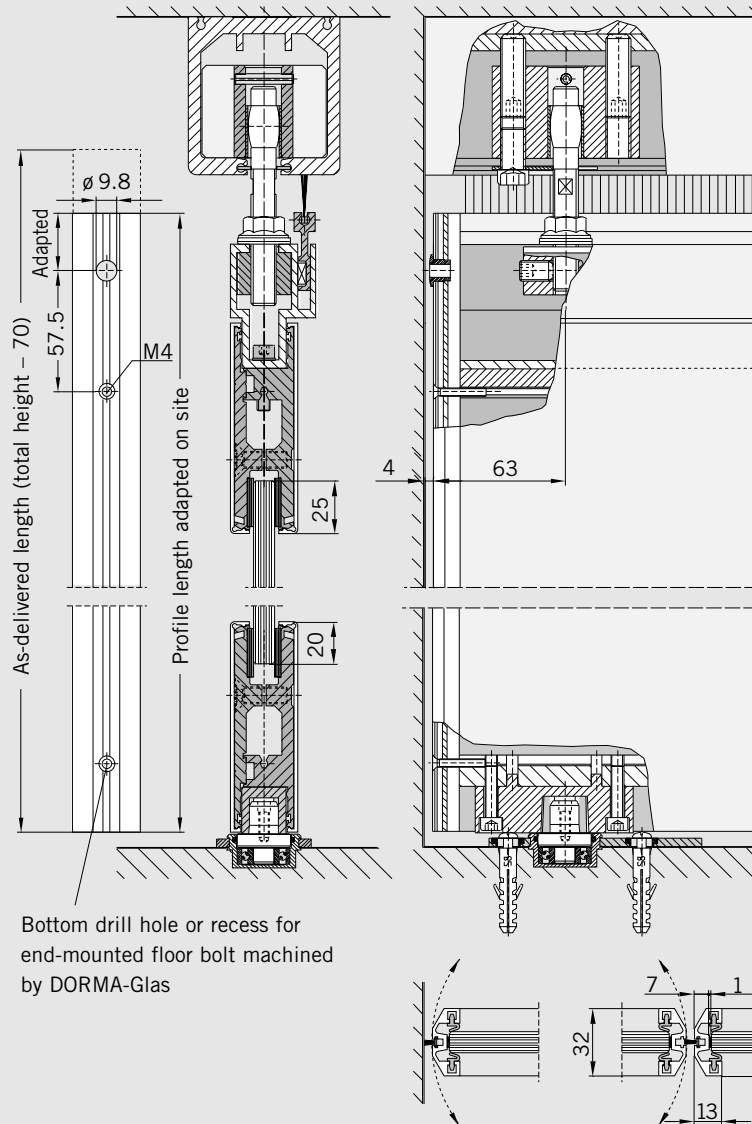

Installation instructions

When fitting the glazing rails, please ensure that the glass protrusion is even over the full length.
Prior to profile machining, first hang the panels from the overhead track and then align.

Sliding panel

Fixed when the frontage or partition is closed.

The sliding panels are the moving elements. Once in their closed position, they are locked down. The components available for this are provided in the bottom glazing rail in the form of face-mounted floor bolts, end-mounted floor bolts, end pin bolts or deadlocks.

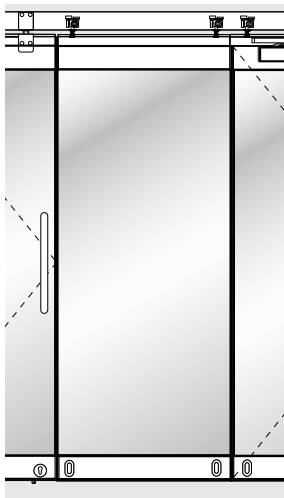

Calculation of the glass width
= Panel width – 16 mm

As-delivered condition:

Cut lengths supplied from factory
= Partition height – 100 mm
Holes and recesses are pre-machined in the profile for the bottom glazing rail only.
Any further machining work required for connection to the top glazing rail has to be performed on site.

Sliding panel

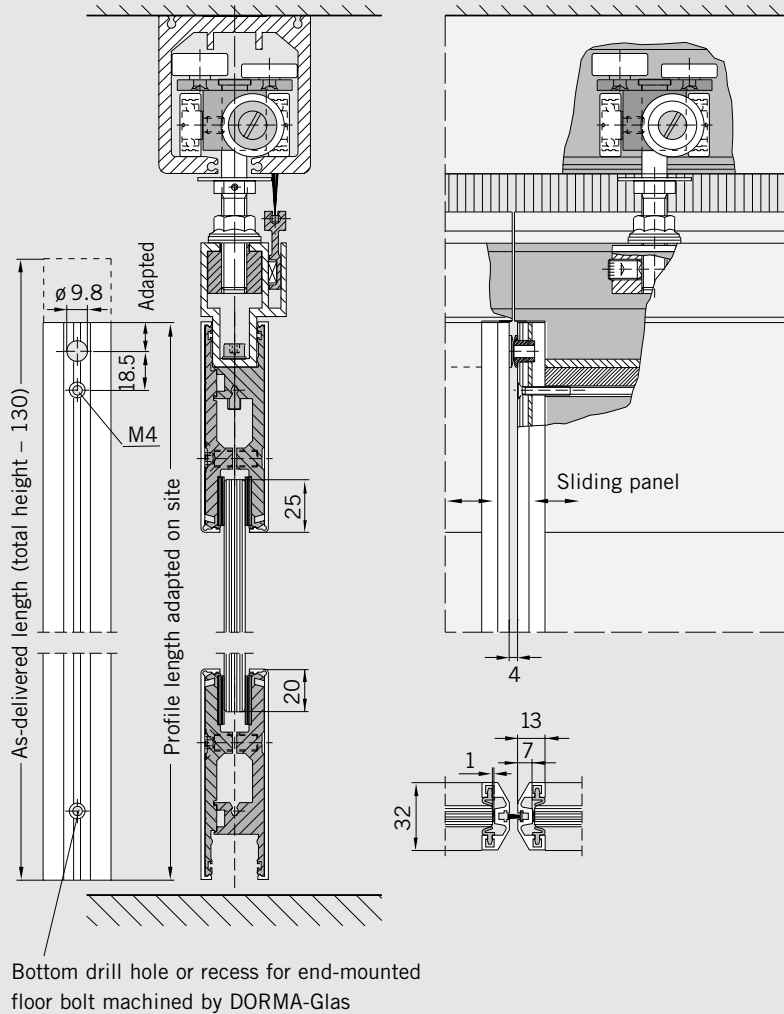

Installation instructions

When fitting the glazing rails, please ensure that the glass protrusion is even over the full length.
Prior to profile machining, first hang the panels from the overhead track and then align.
Use the factory-stamped recesses in the bearing profile for accurate adjustment of the top Fineline profile.

Sliding panels in segmented configurations

Fixed when frontage or partition closed.

The sliding panels are the moving elements. Once in their closed position, they are locked down. The components available for this are provided in the bottom glazing rail in the form of face-mounted floor bolts, end-mounted floor bolts, end pin bolts or deadlocks.

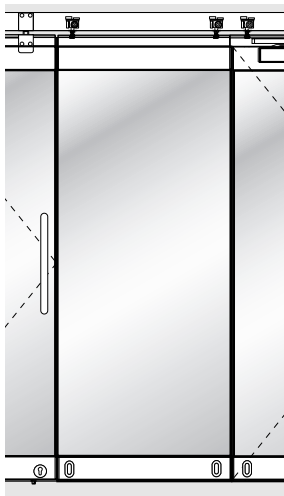

Calculation of the glass width
= Panel width – 16 mm

As-delivered condition:

Cut lengths supplied from factory
= Partition height – 100 mm
Holes and recesses are pre-machined in the profile for the bottom glazing rail only.

Any further machining work required for connection to the top glazing rail has to be performed on site.

Sliding panels in segmented configurations

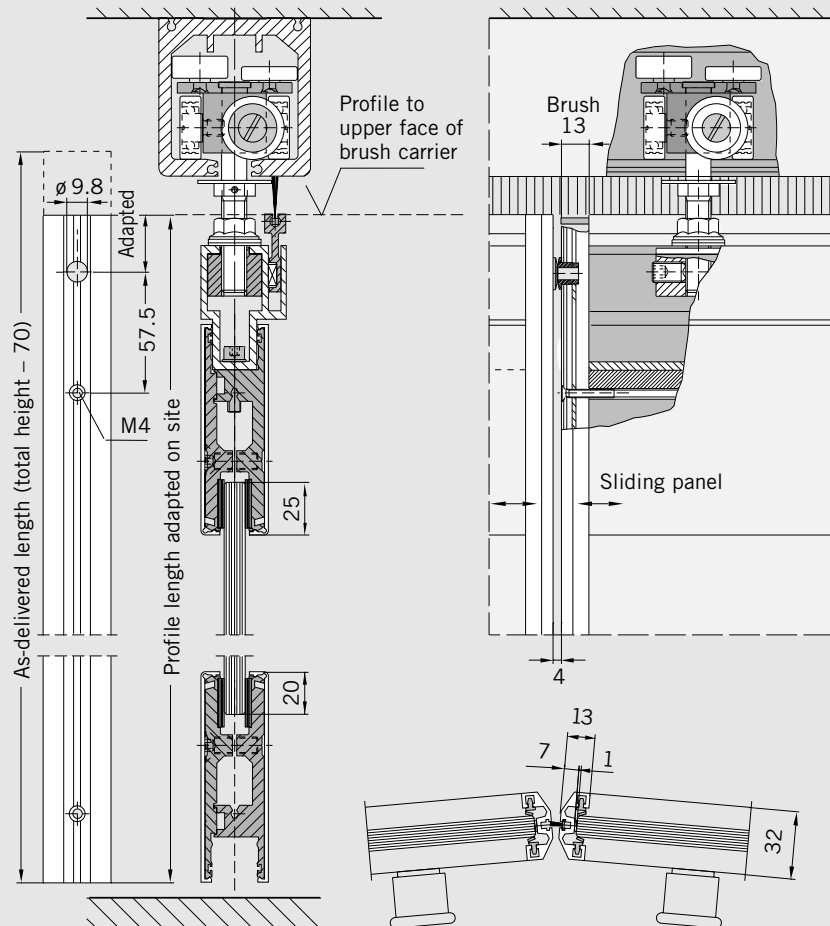

Installation instructions

When fitting the glazing rails, please ensure that the glass protrusion is even over the full length.

Prior to profile machining, first hang the panels from the overhead track and then align.

Double action sliding panel

Double action panel with RTS transom-concealed door closer for door access when frontage or partition closed.

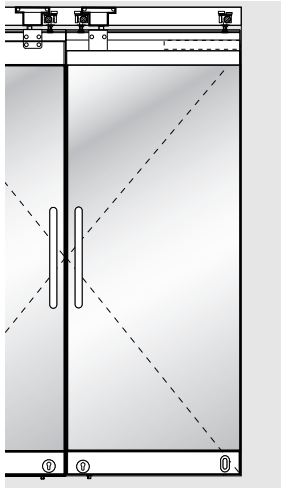

Calculation of the glass width
= Panel width – 16 mm

As-delivered condition:

Cut lengths supplied from factory
= Partition height – 100 mm
Holes and recesses are pre-machined in the profile for the bottom glazing rail only.

Any further machining work required for connection to the top glazing rail has to be performed on site.

Double action sliding panel

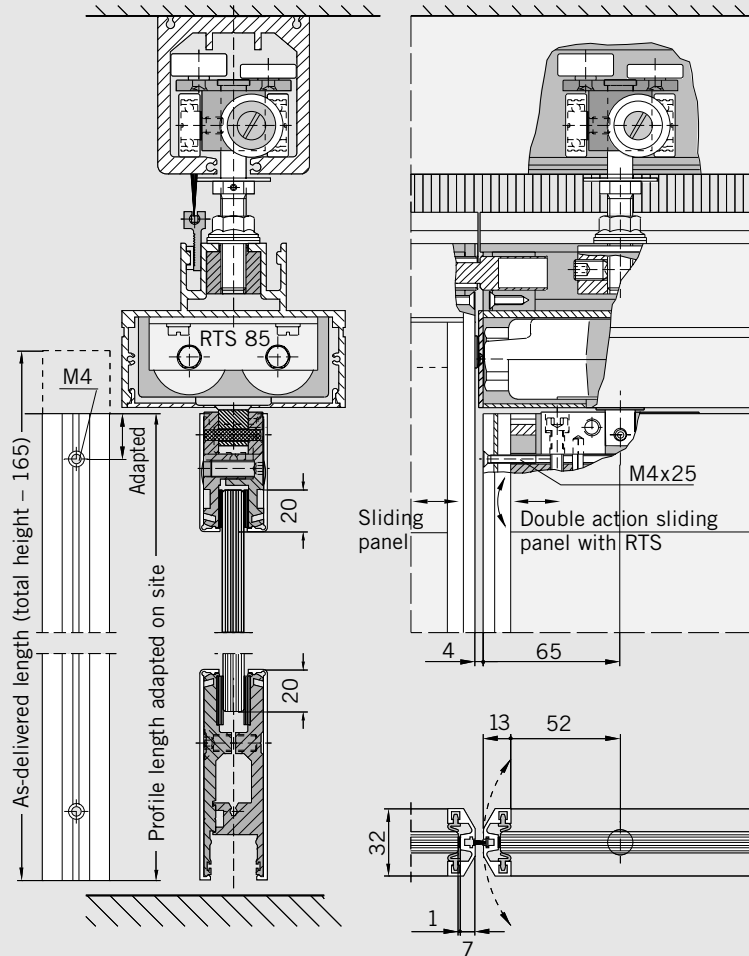

Installation instructions

When fitting the glazing rails, please ensure that the glass protrusion is even over the full length.

Prior to profile machining, first hang the panels from the overhead track and then align.

Folding sliding panel

Hinged, with lock and slide bolt at the bottom, latching bolts top and bottom for fixing the final folding panel to the sliding panel.

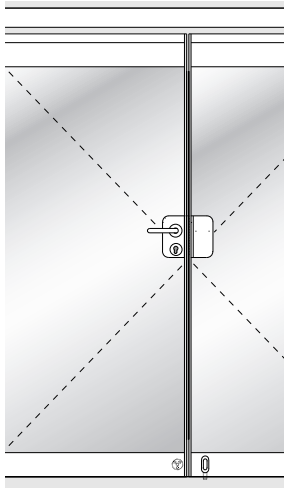

Calculation of the glass width
= Panel width – 16 mm

As-delivered condition:

Cut lengths supplied from factory
= Partition height – 100 mm
Holes and recesses are pre-machined in the profile for the bottom glazing rail only.
Any further machining work required for connection to the top glazing rail has to be performed on site.

Folding sliding panel

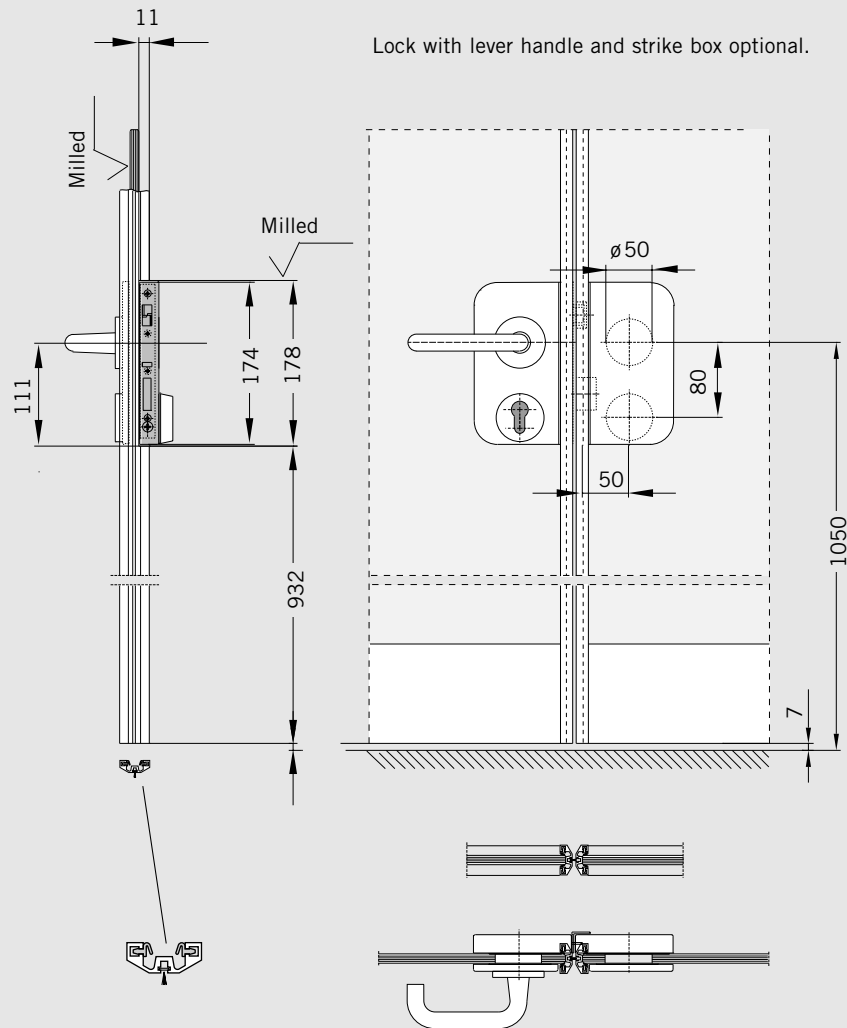

Installation instructions

When fitting the glazing rails, please ensure that the glass protrusion is even over the full length.
Prior to profile machining, first hang the panels from the overhead track and then align.

Fineline Seal

Profile machining

This is performed by DORMA-Glas for the end-mounted and face-mounted slide bolts.

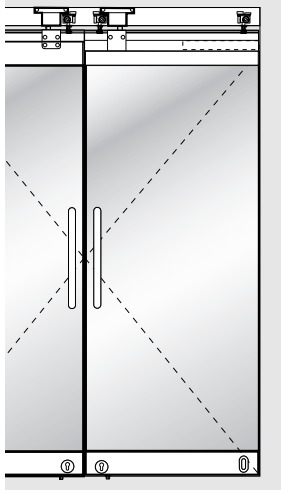

Fineline seal with end-mounted slide bolt

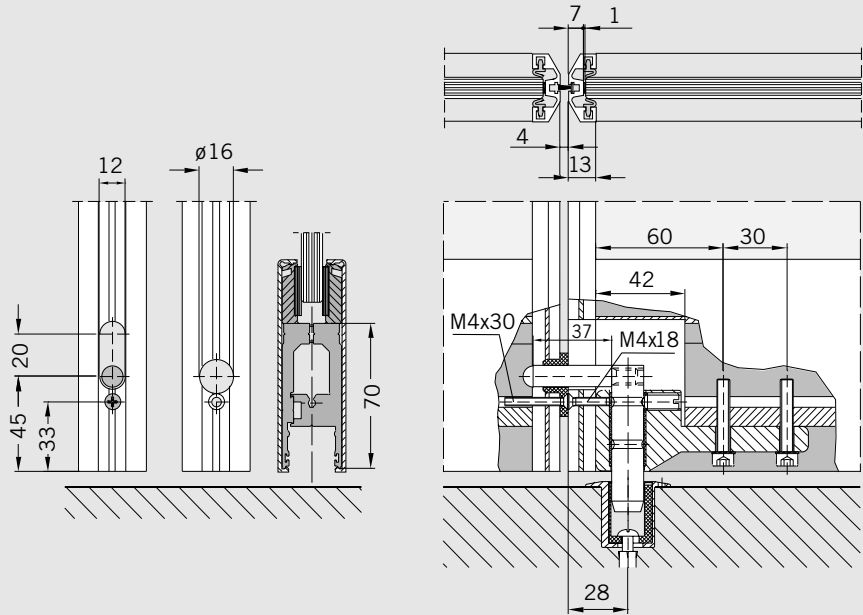

Fineline seal with face-mounted slide bolt

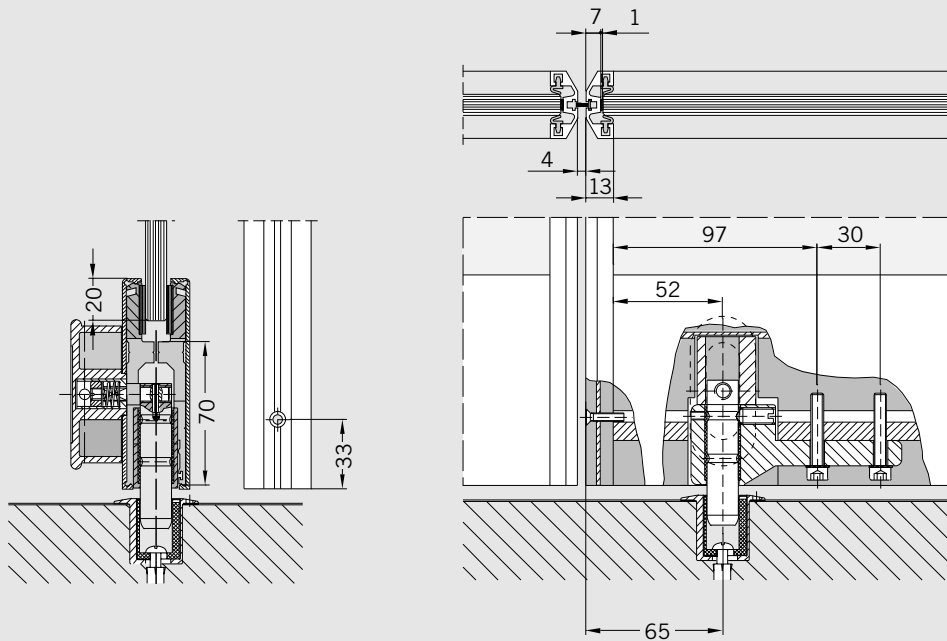

Line Seal

Single action or double action end panels

Non-moving and always equipped with a bottom deadbolt with the option of an additional top bolt or side-action deadlock.
Can be designed as a single action or double action door.

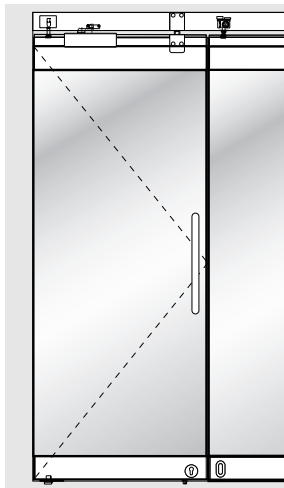

Calculation of the glass width
= Panel width – 30 mm

As-delivered condition:

Cut lengths supplied from factory
= Partition height – 100 mm
Holes and recesses are pre-machined in the profile for the bottom glazing rail only.
Any further machining work required for connection to the top glazing rail has to be performed on site.

Single action or double action end panel with floor pivot

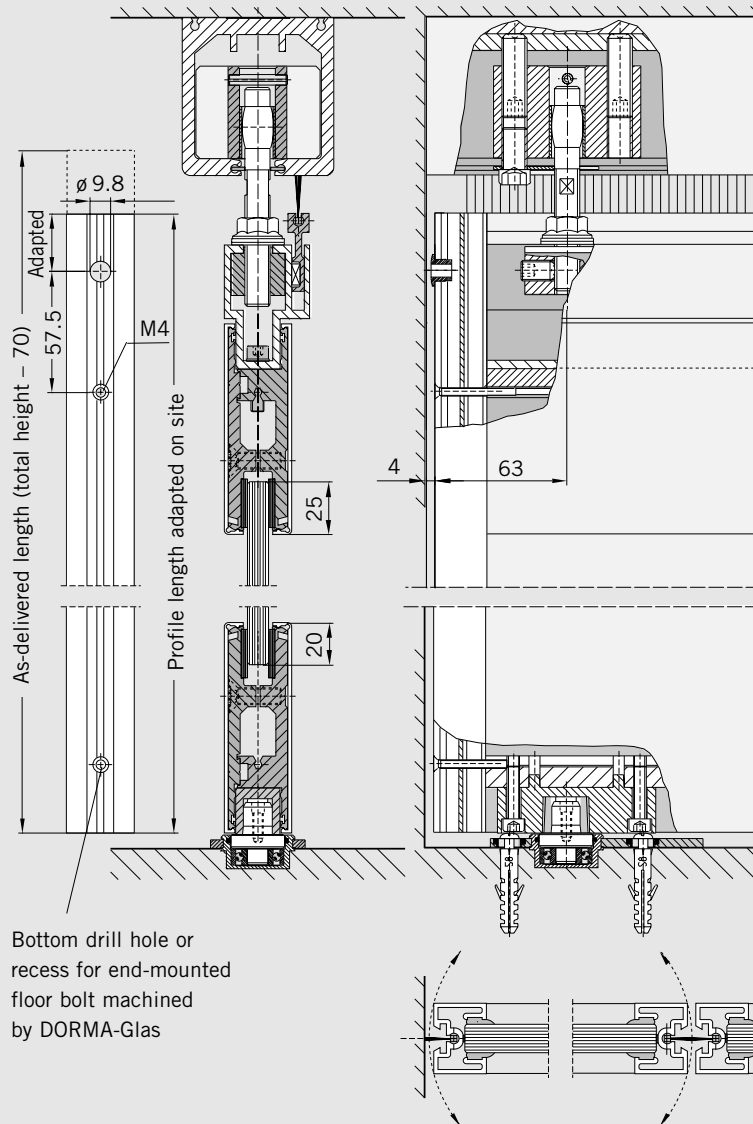

Installation instructions

When fitting the glazing rails, please ensure that the glass protrusion is even over the full length.
Prior to profile machining, first hang the panels from the overhead track and then align

Sliding panel

Fixed when the frontage or partition is closed.

The sliding panels are the moving elements. Once in their closed position, they are locked down. The components available for this are provided in the bottom glazing rail in the form of face-mounted floor bolts, end-mounted floor bolts, end pin bolts or deadlocks.

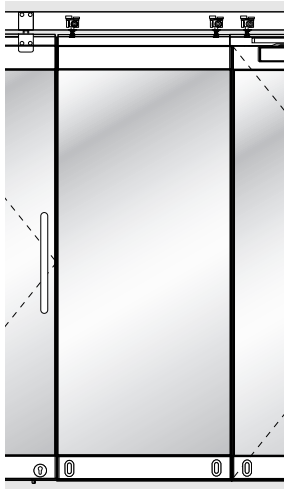

Calculation of the glass width
= Panel width – 30 mm

As-delivered condition:

Cut lengths supplied from factory
= Partition height – 100 mm
Holes and recesses are pre-machined in the profile for the bottom glazing rail only.
Any further machining work required for connection to the top glazing rail has to be performed on site.

Sliding panel

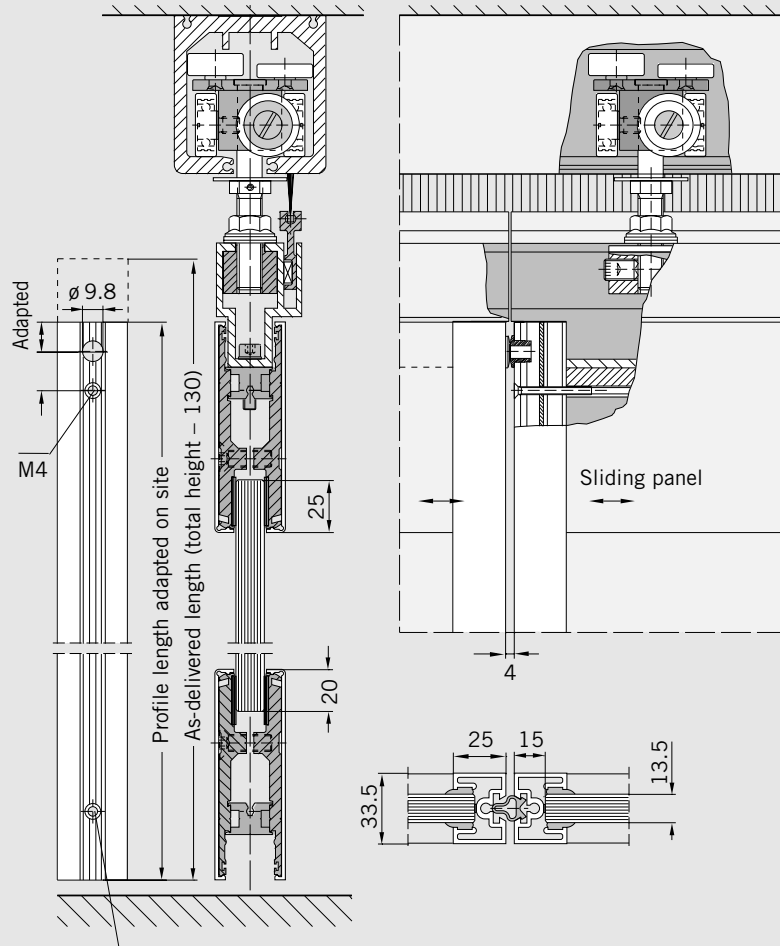

Bottom drill hole or recess for end-mounted floor bolt machined by DORMA-Glas

Installation instructions

When fitting the glazing rails, please ensure that the glass protrusion is even over the full length.
Prior to profile machining, first hang the panels from the overhead track and then align.

Double action sliding panel

Double action panel with RTS transom-concealed door closer for door access when frontage or partition closed.

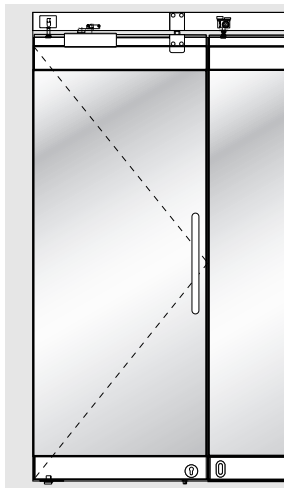

Calculation of the glass width
= Panel width – 30 mm

As-delivered condition:

Cut lengths supplied from factory
= Partition height – 100 mm
Holes and recesses are pre-machined in the profile for the bottom glazing rail only.

Any further machining work required for connection to the top glazing rail has to be performed on site.

Double action sliding panel

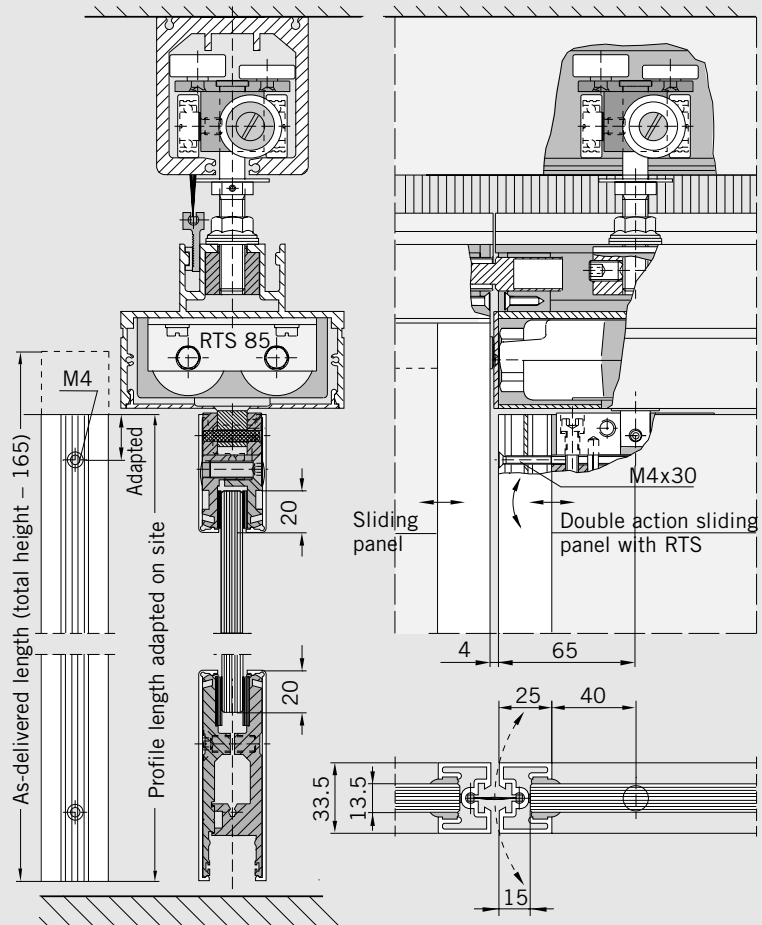

Installation instructions

When fitting the glazing rails, please ensure that the glass protrusion is even over the full length.

Prior to profile machining, first hang the panels from the overhead track and then align.

Profile machining

This is performed by DORMA-Glas for the end-mounted and face-mounted slide bolts.

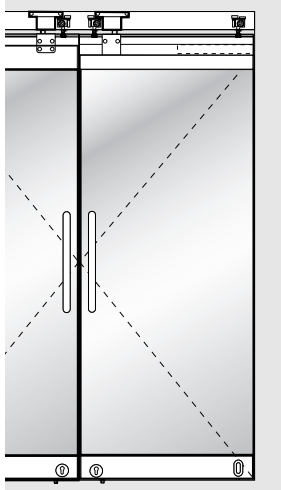

Line seal with end-mounted slide bolt

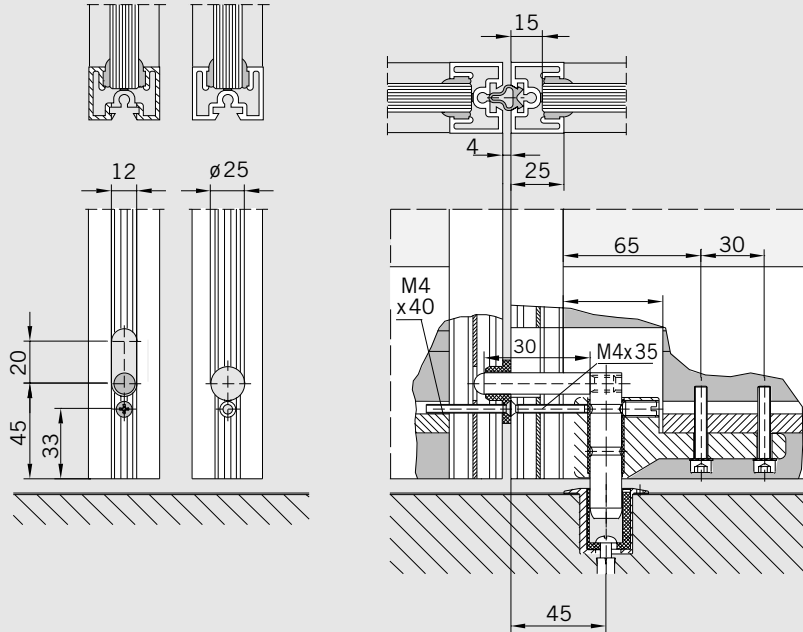

Line seal with end-mounted slide bolt

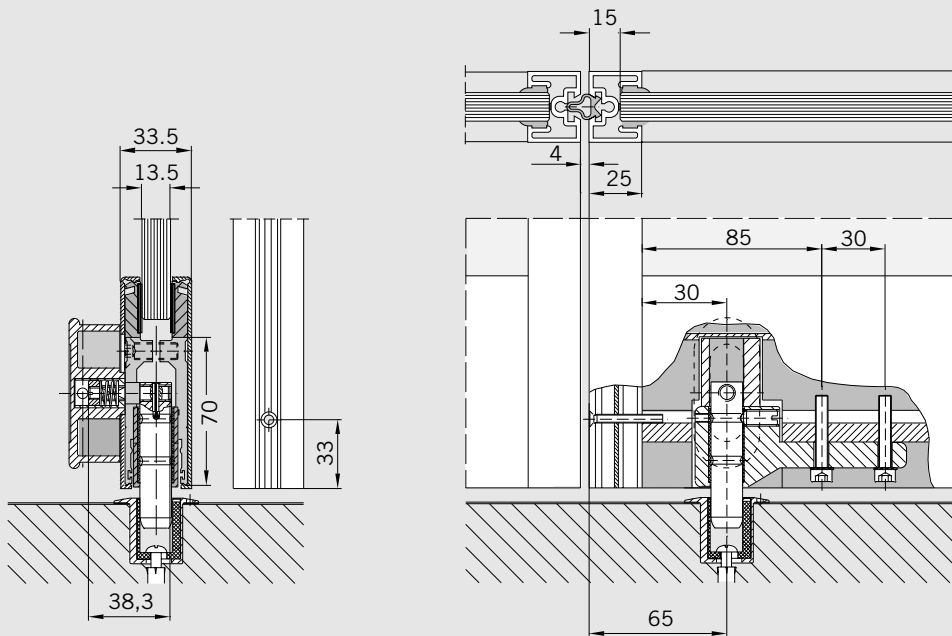

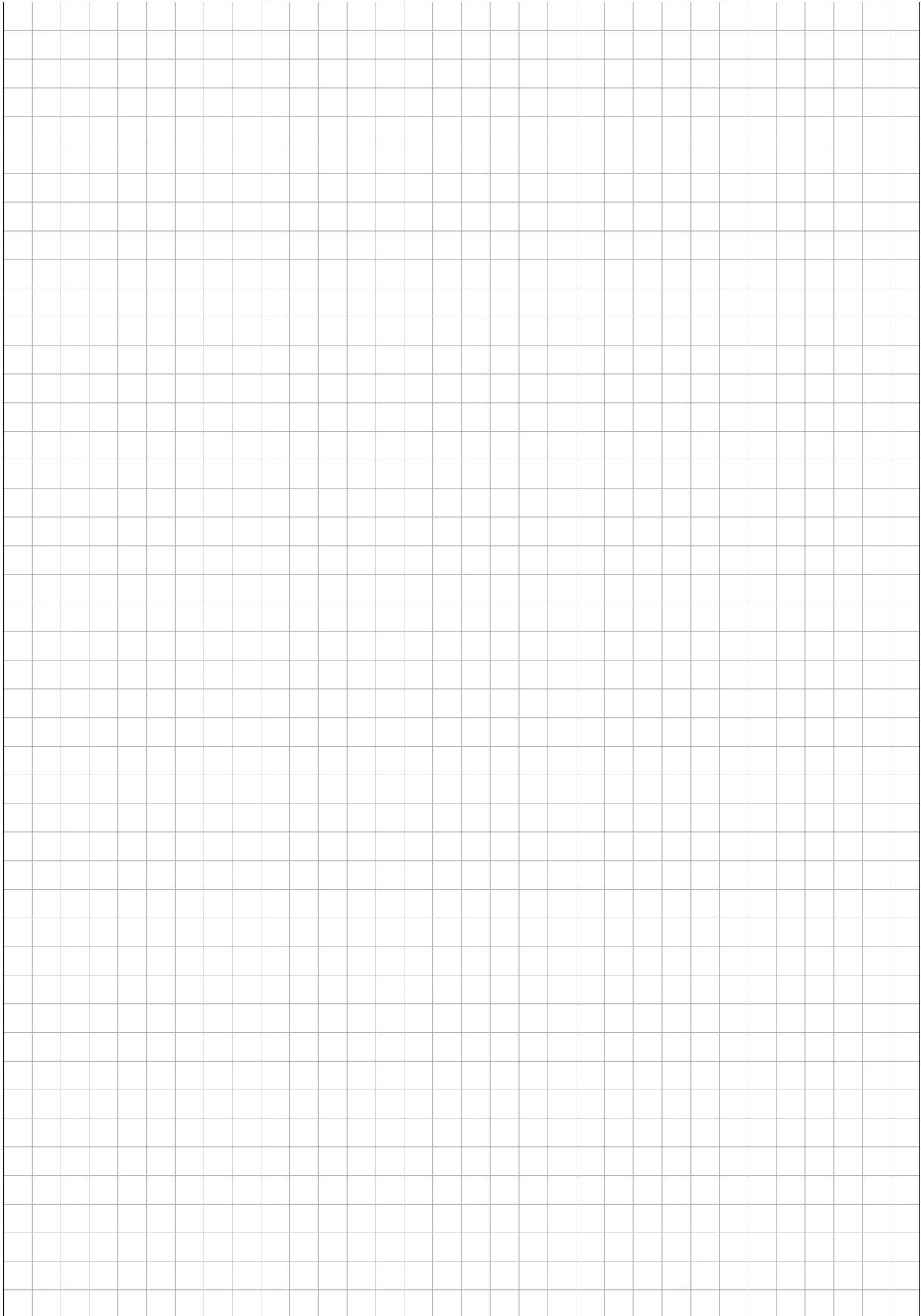

Floor Track for sliding panels

A floor track in the form of a stainless steel channel section (U-profile) is also available as an option. This can be used for HSW-G and HSW-R sliding panels irrespective of the partition layout. In special cases and after technical clarification, it may also be used with HSW-GP sliding panels. For this, the end-mounted floor bolt usually applied for straight-line partition configurations is replaced by a combination of guide pin and end pin. The guide pin must be vertically below the track roller and is adjustable in the range ± 10 mm. For abutment to single action/double action end panels and also in the case of angled configurations, a face-mounted floor bolt is replaced by a bottom deadlock.

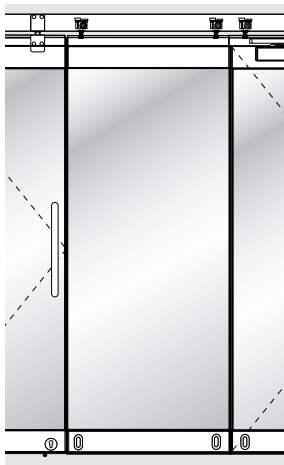

The floor track is available in three designs:

- Straight
- 90° curve
- 135° curve

The individual track sections are abutted and fixed in place by means of a stainless steel connector.

In its as-delivered condition, the floor track comes with a welded flange for fixing to the unfinished floor. This can be removed if not required.

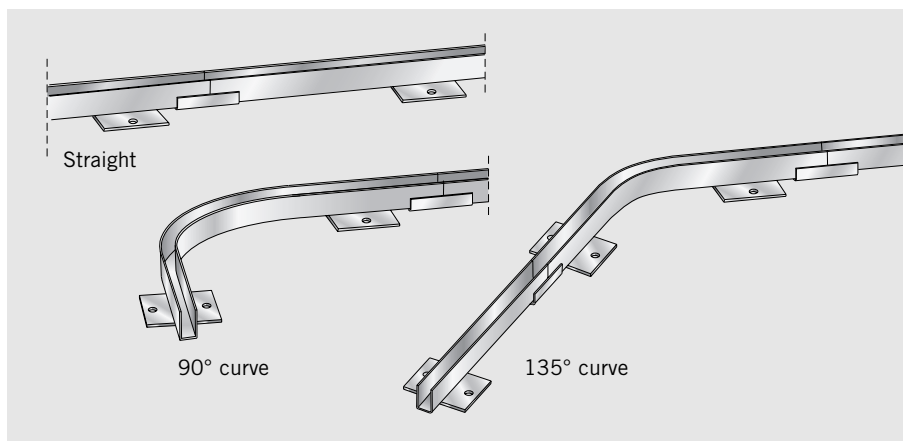
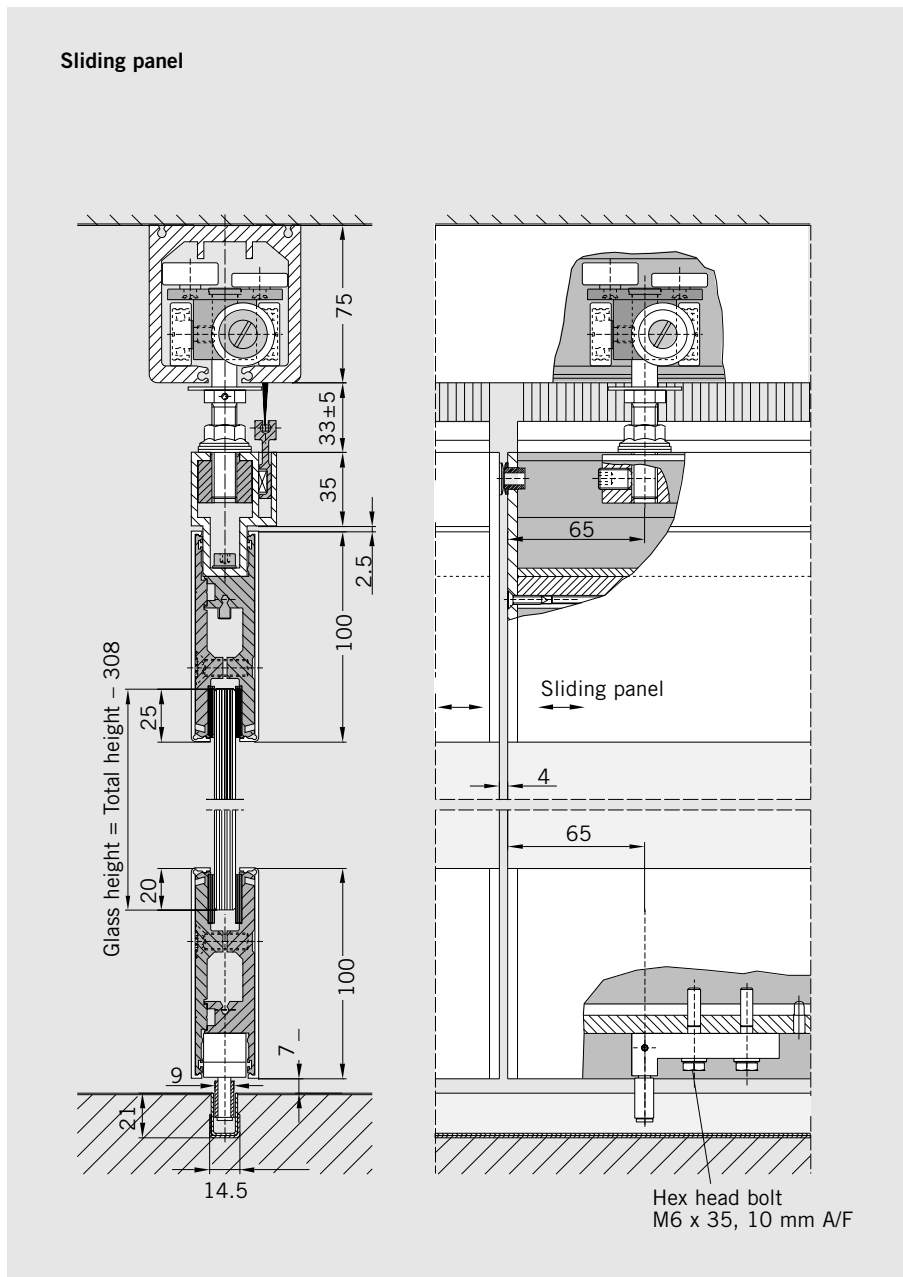

Floor track Stacking track detail

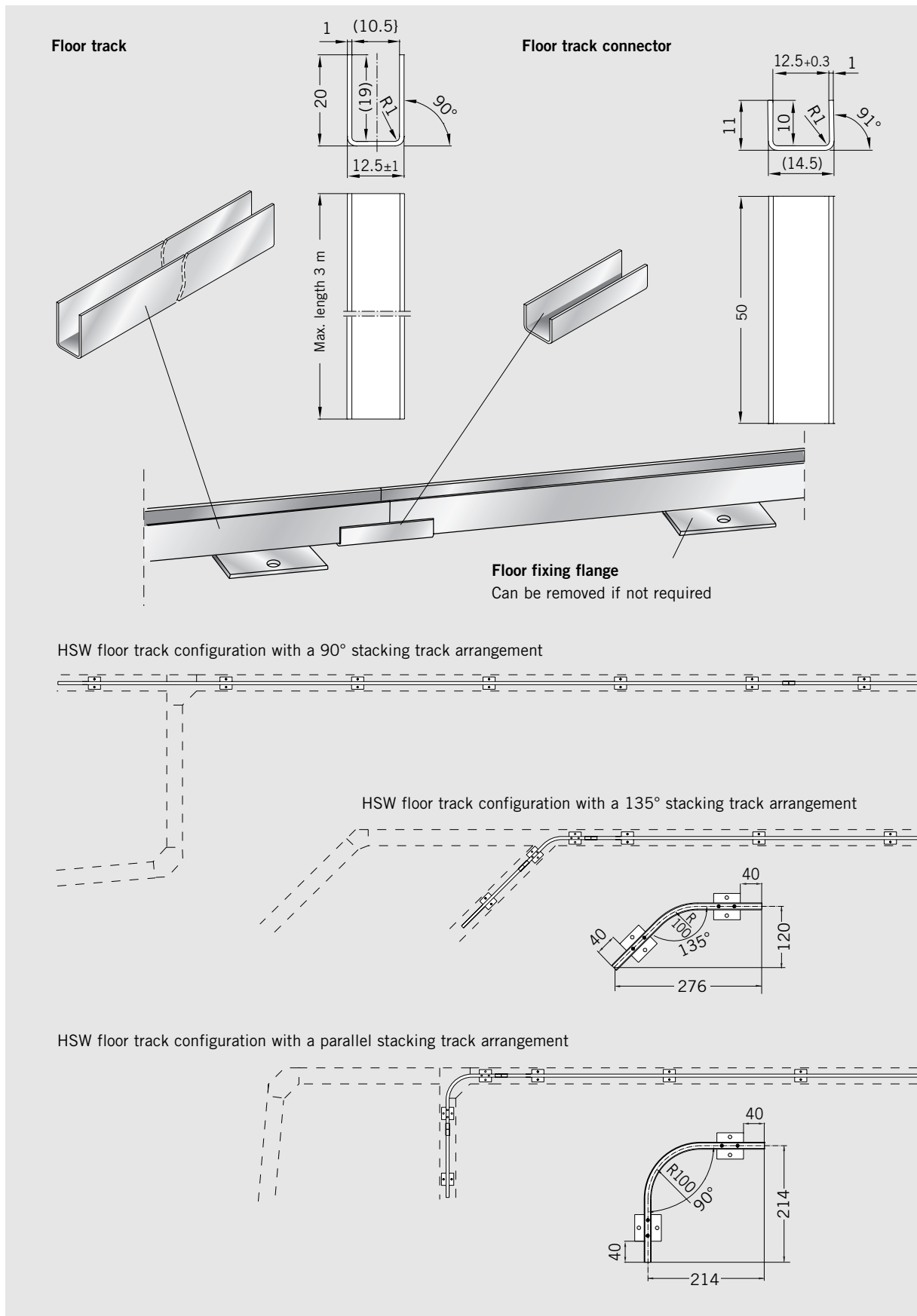

Measuring up

Important site measurements

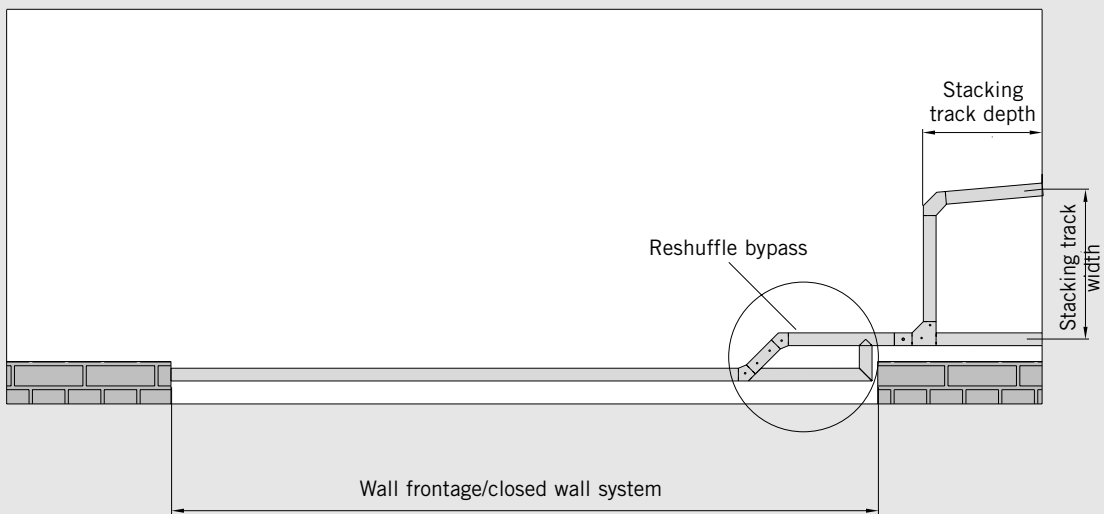
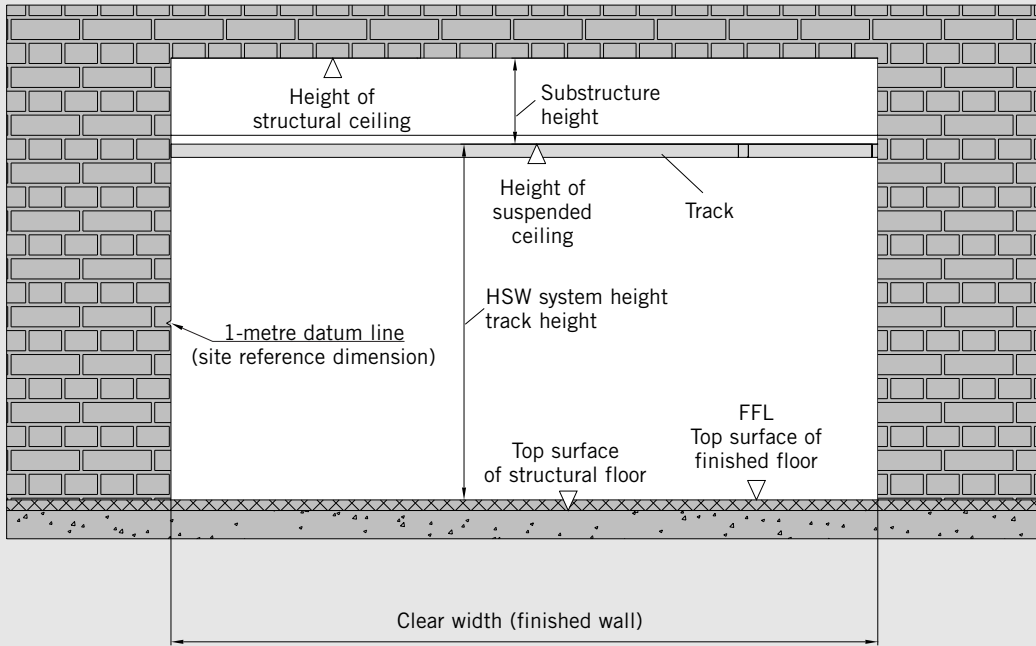

Notes on portal systems

Maintenance recommendation for high-frequency HSW systems

Horizontal glass walls have been developed in order to provide retail outlets with generous and enticing frontages – entrances that offer easy accessibility and an inviting appearance for customers. When the frontages are closed, they can double up as expansive shop windows.

In cases where double-action sliding panels are used for main entrances as a portal system (i. e. shopping malls or similar operated HSW systems) they are submitted to very high daily traffic volumes and usage frequency rates. The door closers and pivot bearings used by DORMA-Glas have been successfully tested in accordance with the requirements of EN 1154. EN 1154 specifies 500,000 test cycles for manually operated closing devices. High-frequency portal systems such as the above can reach this number of cycles after just a few months. Consequently, DORMA-Glas recommends that such units be regularly maintained.

The higher the usage levels, the more frequently the equipment should be serviced by either the installation firm or a similarly specialised fitter.

Planning tools



For planning of intelligent glass solutions we offer you several planning tools which allow you to create secure and professional solutions for any kinds of glass doors and toughend glass assemblies.

The planning tools DGES and MANET COMPACT enable you to prepare designs and cost calculations quickly, reliably and professionally. The software provides you with all necessary documentation such as dimensioned technical drawings, glass sizes and preparation measures.

Your benefits:

- Easy to operate
- Professional and error-free preparation of offers
- Rapid response to incoming requests for quotations
- Highly reduced planning costs for time and money savings

DGES Fittings

(for internal doors and toughend glass assemblies),
Art. No. 800.51.248.6.32

DGES HSW (for horizontal sliding walls),
Art. No. 800.51.247.6.32

DGES Showers (for glass shower cubicles),
Art. No. 600.51.600.9.03

MANET COMPACT planning tool
(for MANET pivoting and sliding doors),
Art. No. 800.51.329.6.32

Finishes

Deviations in colour due to production procedures cannot be totally excluded.

HSW systems with surface finishes 502, 503, 700 and 701 contain different component materials.

In the case of FSW (folding/sliding) systems, for example, the folding hinges are always of aluminium, while the standard surface finish for brush profiles and end covers is black anodised (E6/C35). These various components and also the top locks can also optionally be anodised or powder-coated so that they resemble the ordered surface finish.

Owing to the use of different materials and processes, variations can occur in the appearance of the surface finishes and colours.

Finishes

Aluminium Description	DORMA-Glas No.	similar Eloxal I	similar Eloxal II
Alumin. mill finish	100		
Alumin. silver	101	EV1	C 0
Alumin. similar satin stainl. steel	107		
Alumin. similar satin stainl. steel (for profile material)	113		C 31
Special anodised	199		
Coated colours Description	DORMA-Glas No.	similar HEWI-Nr.	similar RAL
Alumin. white	300	99	9016
Special coated colour	399		

Brass Description	DORMA-Glas No.
Brass polished varnished	502
Brass polished	503

Stainless steel Description	DORMA-Glas No.
Satin stainless steel	700
Polished stainless steel	701

General care instructions

The surface finishes of the fittings are not maintenance-free and should be cleaned according to their material and design. For metallic surfaces (anodised finishes, stainless steel) please use appropriate cleaning agents without abrasive additives only. For varnished surfaces please use appropriate solvent-free cleaning agents only.

Brass surfaces (without surface protection) have to be treated with an appropriate maintenance agent on occasion, to avoid tarnishing.

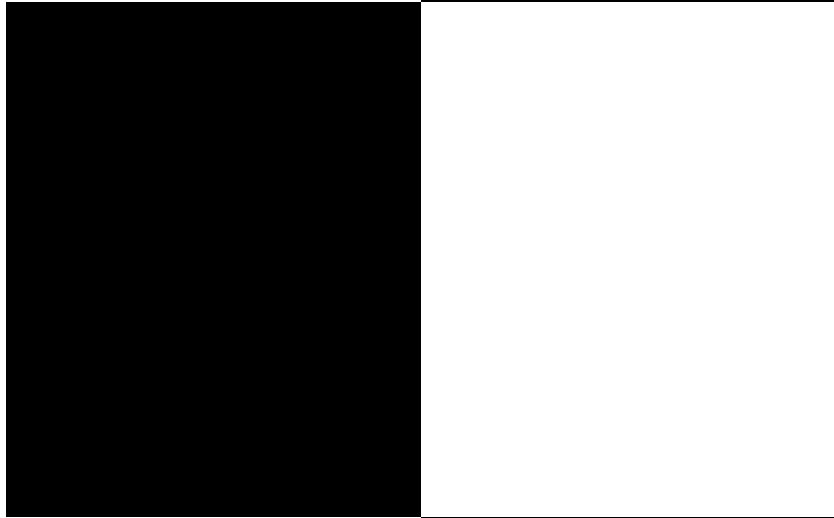

Division Glasbeschlagtechnik
Glass fittings and accessories
DORMA-Glas GmbH
Postfach 32 68
D-32076 Bad Salzufen
Max-Planck-Straße 33 - 45
D-32107 Bad Salzufen
Tel. +49 5222 924-0
Fax +49 5222 21009
www.dorma.com